

**SOCIETY OF ECOLOGICAL CHEMISTRY  
AND ENGINEERING**

---

# **Proceedings of ECOpole**

**Vol. 7**

**No. 1**

---

**2013**

#### **EDITORIAL COMMITTEE**

**Maria WACŁAWEK (University, Opole) - Editor-in-Chief**

Michael BRATYCHAK (Lviv Polytechnic National University, Lviv, UA) - chemical technology

Stanisław MAZUR (University of Agriculture, Kraków, PL) - agricultural chemistry

Pavlina SIMEONOVA (Bulgarian Academy of Sciences, Sofia, BG) - heavy metals

#### **SCIENTIFIC BOARD**

Witold WACŁAWEK (Society of Ecological Chemistry and Engineering, PL) - Chairman

Jerzy BARTNICKI (Meteorological Institute DNMI, Oslo-Blindern, NO)

Mykhaylo BRATYCHAK (National University of Technology, Lviv, UA)

Bogusław BUSZEWSKI (University, Toruń, PL)

Andrzej GAWDZIK (University, Opole, PL)

Milan KRAITR (Western Bohemian University, Plzeň, CZ)

Andrzej KULIG (University of Technology, Warszawa, PL)

Bernd MARKERT (International Graduate School [IHI], Zittau, DE)

Jacek NAMIEŚNIK (University of Technology, Gdańsk, PL)

Mark R.D. SEAWARD (University of Bradford, Bradford, UK)

Vasil SIMEONOV (University of Sofia, Sofia, BG)

Antonin SLABÝ (University, Hradec Králové, CZ)

Wiesław WASIAK (University, Poznań, PL)

Roman ZARZYCKI (University of Technology, Łódź, PL)

Andrzej KŁOS (University, Opole, PL) - Secretary

#### **STATISTICAL EDITOR**

Władysław KAMIŃSKI (University of Technology, Łódź, PL)

#### **LANGUAGE EDITORS**

Ian BARNES (University of Wuppertal, Wuppertal, DE)

Zdzisława TASARZ (University of Technology, Częstochowa, PL)

#### **Editorial Office**

Opole University

ul. kard. B. Kominka 6, 45-035 Opole

phone +48 77 455 91 49, +48 77 455 91 49

fax +48 77 401 60 51

email: maria.waclawek@uni.opole.pl

#### **Secretary Office**

phone +48 77 401 60 42

email: mrajfur@o2.pl

#### **Copyright © by**

**Society of Ecological Chemistry and Engineering**

**The primary version of the journal is the online one**

**Proceedings of ECOpole**

**were partly financed by**

**Ministry of Science and Higher Education, Warszawa**

**ISSN 1898-617X**

Dear Readers,

We would like to inform you, that scientific semi-annual *Proceedings of ECOpole* is in Conference Proceedings Citation Index on the **Web of Science, Thomson Reuters, Philadelphia.**

We thank very much  
all Editorial Board members and Reviewers  
for their efforts  
and also Authors for presenting valuable papers

*Editors*

Szanowni Czytelnicy,

Miło jest nam poinformować, że półrocznik *Proceedings of ECOpole* znajduje się na the **Web of Science, Thomson Reuters, Philadelphia.**

*Proceedings of ECOpole* jest umieszczony w **Wykazie czasopism** Ministerstwa Nauki i Szkolnictwa Wyższego.

Za publikację w nim **przysługuje 5 punktów.**

Serdecznie dziękujemy Członkom Rady Programowej i Recenzentom za dokładanie starań o wysoki poziom naukowy czasopisma, a także Autorom za przedstawianie interesujących wyników badań

*Redakcja*



## CONTENTS / SPIS TREŚCI

<b>Papers/Artykuły</b> .....	11
Wojciech BARAN, Ewa ADAMEK, Justyna ZIEMIAŃSKA Andrzej MAKOWSKI and Andrzej SOBCZAK Assessment of susceptibility of sulfonamide drugs to biodegradation in environmental samples .....	13
Krzysztof BARBUSIŃSKI, Magdalena AMALIO-KOSEL Barbara PIECZYKOLAN, Izabela PŁONKA and Sławomir FAJKIS Studies of optimization of colored wastewater treatment by Fenton's reagent (Part I) .....	23
Wojciech BIERZA, Aleksandra NADGÓRSKA-SOCHA Elżbieta MAŁKOWSKA and Ryszard CIEPAŁ Evaluation of the soil enzymes activity as an indicator of the impact of anthropogenic pollution on the Norway spruce ecosystems in the Silesian Beskid .....	29
Elżbieta BOLIGŁOWA, Katarzyna GLEŃ, Janina GOSPODAREK and Andrzej SKOCZOWSKI Evaluation of chemical protection effect on healthiness of broad bean leaves and elements of yielding .....	37
Tomasz CIESIELCZUK, Czesława ROSIK-DULEWSKA and Jacek LENARTOWICZ Investigations of composts as a potential sorbents of aliphatic hydrocarbons .....	43
Marcin DĘBOWSKI, Magda DUDEK, Marcin ZIELIŃSKI and Anna GRALA Technological effectiveness of methane fermentation of prairie cordgrass ( <i>Spartina pectinata</i> ) .....	49
Katarzyna GLEŃ, Elżbieta BOLIGŁOWA and Katarzyna ZNÓJ Evaluation of manganese seed dressings effect on healthiness of spring barley .....	59
Janina GOSPODAREK Bioremediation of soil polluted with oil derivatives and its effect on Coleoptera, Carabidae occurrence .....	67
Katarzyna GRATA and Małgorzata NABRDALIK Antifungal activity of bacterial species <i>Bacillus</i> against <i>Alternaria</i> sp. ....	75

---

Anna IŻEWSKA, Justyna CHUDECKA, Tomasz TOMASZEWICZ and Mariola WRÓBEL Content of elements in soils of roadsides and characteristic of plant species settled .....	81
Agnieszka JAGODA, Witold ŻUKOWSKI and Barbara DĄBROWSKA Presence of caffeine in the Rudawa River and its tributaries .....	87
Anna JANICKA In-vehicle toxicity measurements: in-vitro tests as a new method of toxicological estimation of car cabin atmosphere .....	93
Bartosz KAŻMIERCZAK Modelling of discharges from storm overflows on a combined sewage system .....	101
Aleksandra KIECAK, Ewa KRET and Grzegorz MALINA Intrinsic biodegradation potentials in groundwater contaminated with tri- and tetrachloroethene in the vicinity of Nowa Deba waterworks .....	109
Andrzej KOTOWSKI and Bartosz KAŻMIERCZAK Dimensioning of the sewerage system .....	117
Artur KUBICZEK and Władysław KAMIŃSKI Ionic liquids for the extraction of n-butanol from aqueous solutions .....	125
Małgorzata MUSIALIK, Marcin M. CHRZANOWSKI, Irmina BUCZEK Enzo B. ARÉVALO-GARCIA and Barbara OSTROWSKA Elements of environmental education in the new Polish curriculum for teaching chemistry and selected chemistry textbooks at ISCED 2 and ISCED 3 level .....	133
Kamila J. NOWAK, Andrzej T. SOLECKI and Tobiasz J. SZADEJ Radiological risk of the uraniferous coal waste in the case of the landscape architecture application .....	143
Halina PAWLAK-KRUCZEK and Maciej ZAWIŚLAK CFD modeling of pulverized coal combustion in air and oxy atmosphere - NO <sub>x</sub> and SO <sub>2</sub> formation .....	149
Matúš PEŠKO and Katarína KRÁĽOVÁ Physiological response of <i>Brassica napus</i> L. plants to Cu(II) treatment .....	155
Michał RYMS, Witold M. LEWANDOWSKI Ewa KLUGMANN-RADZIEMSKA, Katarzyna JANUSZEWICZ and Krzysztof CIUNEL Methods of liquid biofuel production - the bioethanol example .....	163
Zbigniew SUCHORAB Laboratory measurements of moisture in a model red-brick wall using the surface TDR probe .....	171

Maciej ZAWIŚLAK Impact of vehicle interior geometry on chosen volatile carcinogens concentration distribution in vehicle cabin .....	177
<b>Artykuły/Papers</b> .....	185
Ewa ADAMEK, Maciej GONIEWICZ, Wojciech BARAN i Andrzej SOBCZAK Badania nad fotokatalitycznym rozkładem nikotyny .....	187
Agnieszka BARAN, Czesława JASIEWICZ i Marek TARNAWSKI Wpływ osadów dennych pobranych ze zbiornika Besko na plon i zawartość makroelementów w biomase kukurydzy .....	193
Krzysztof FRĄCZEK, Helena BIS, Jacek GRZYB, Dariusz ROPEK i Jerzy WIECZOREK Występowanie grzybów toksynotwórczych i patogennych na powierzchni nasion oraz bulw roślin rolniczych uprawianych w okolicy składowiska odpadów komunalnych .....	199
Anna FURMAŃCZUK Reakcja aparatu fotosyntetycznego fasoli szparagowej na nadmiar kobaltu w podłożu .....	207
Beata KUZIEMSKA i Stanisław KALEMBASA Wpływ wapnowania i dodatku osadu ściekowego na rozmieszczenie frakcji Zn i Cr w glebie zanieczyszczonej nikiem .....	215
Elżbieta MAŁKOWSKA, Bernard PALOWSKI, Łukasz MAŁKOWSKI Wojciech BIERZA i Karolina SZEWCZYKOWSKA Przydatność wybranych organów <i>Robinia pseudoacacia</i> do celów bioindykacyjnych .....	223
Anna PIOTROWSKA-DŁUGOSZ, Jacek DŁUGOSZ Mirosław KOBIERSKI i Edward WILCZEWSKI Zróżnicowanie zawartości N-ogółem oraz aktywności enzymów przemian azotu w glebie płowej i czarnej ziemi regionu Pomorza i Kujaw .....	229
Dariusz ROPEK i Janina GOSPODAREK Wpływ ropopochodnych na zdolność do migracji nicienia owadobójczego <i>Steinernema feltiae</i> .....	237
Anetta SIWIK-ZIOMEK i Jan KOPER Wpływ nawożenia obornikiem i doboru roślin na zawartość siarczanów(VI) i aktywność arylosulfatazy w glebie płowej .....	241

---

Paweł SKONIECZEK, Józef KOC i Marcin DUDA Wpływ zbiorników retencyjnych w ochronie jezior przed zanieczyszczeniami spływającymi z obszarów wiejskich .....	247
Lech SMOCZYŃSKI, Regina WARDZYŃSKA i Beata ZAŁĘSKA-CHRÓST Symulacja komputerowa procesu koagulacji zawiesiny ściekowej .....	253
Ilona Joanna ŚWITAJSKA, Sławomir SZYMCZYK i Józef KOC Wpływ sposobu użytkowania terenu na jakość wód gruntowych .....	259
Elwira TOMCZAK, Władysław KAMIŃSKI i Dominika SZCZERKOWSKA Zastosowanie pochodnych ułamkowych do matematycznego opisu kinetyki sorpcji dla układu sorbent roślinny - jony metali ciężkich .....	267
Ewa ADAMEK, Wojciech BARAN, Andrzej SOBCZAK i Natalia SZCZEPKA Wpływ soli $Fe^{3+}$ na fotokatalityczny rozkład substancji promieniochronnych w wodnej zawieszynie $TiO_2$ .....	273
Agnieszka BARAN i Jerzy WIECZOREK Ocena zagrożenia związanego z zawartością metali ciężkich w glebach na terenie powiatu olkuskiego (woj. małopolskie) .....	281
Łukasz BĄK, Jarosław GÓRSKI, Anna RABAJCZYK i Mirosław SZWED Zawartość związków metali ciężkich w osadach dennych zbiornika Suchedniów .....	287
Anna CHRZAN Zawartość wybranych metali ciężkich w glebie i faunie glebowej .....	295
Iwona DESKA i Ewa OCIEPA Wpływ wahań poziomu zwierciadła wody podziemnej na różnicę między miąższością pozorną i rzeczywistą LNAPL .....	303
Joanna DŁUGOSZ i Jarosław GAWDZIK Ocena skuteczności funkcjonowania oczyszczalni ścieków w Barczy (woj. świętokrzyskie) .....	311
Mariusz DUDZIAK i Aleksandra ZGÓRSKA Powstawanie produktów ubocznych oraz ich toksyczność w procesach utleniania wody zawierającej zearalenon .....	319
Beata FURGA, Magdalena GEMBAL, Joanna CEBULSKA Paweł MAŁAGOCKI, Jadwiga PISKORSKA-PLISZCZYŃSKA i Sebastian MASZEWSKI Zastosowanie metody przesiewowej oznaczania dioksyn w sytuacjach kryzysowych .....	325



Katarzyna GÓRSKA i Mikołaj SIKORSKI Występowanie metali ciężkich w ściekach deszczowych na przykładzie zlewni miejskiej w Kielcach .....	333
Jacek GRZYB i Krzysztof FRĄCZEK Porównawcze badania bakteriologicznego zanieczyszczenia powietrza na obszarze zurbanizowanym oraz na obiektach komunalnych .....	343
Andrzej JAGUŚ, Martyna A. RZĘTAŁA, Mariusz RZĘTAŁA Ocena zanieczyszczenia osadów w zbiornikach wodnych w aspekcie użytkowania gruntów .....	349
Katarzyna M. JAROMIN-GLEŃ i Grzegorz ŁAGÓD Sprawność usuwania wybranych zanieczyszczeń ze ścieków miejskich w laboratoryjnym bioreaktorze typu SBR .....	357
Anna KRYSA i Dariusz ROPEK Patogeniczność wybranych szczepów grzyba <i>Metarhizium anisopliae</i> wobec stonki ziemniaczanej ( <i>Leptinotarsa decemlineata</i> ) .....	365
Grzegorz KUSZA Wybrane właściwości magnetyczne osadów dennych Jeziora Turawskiego .....	371
Ewa ŁOBOS-MOYSA Ocena stopnia zanieczyszczenia związkami organicznymi Kanału Gliwickiego i jego wybranych dopływów .....	377
Tomasz OLSZOWSKI Porównanie metod pomiaru depozycji atmosferycznej .....	385
Mariola RAJCA Usuwanie zanieczyszczeń z wód w hybrydowym reaktorze membranowym przy współdziałaniu procesu MIEX <sup>®</sup> DOC .....	393
Lech SMOCZYŃSKI, Kamilla Teresa MUŃSKA, Marta KOSOBUCKA Bogusław PIEROŻYŃSKI, Regina WARDZYŃSKA i Beata ZAŁĘSKA-CHRÓST Destabilizacja ścieków modelowych w procesie koagulacji chemicznej .....	399
Agnieszka SOBIANOWSKA-TUREK, Włodzimierz SZCZEPANIAK Tadeusz MARCINKOWSKI i Dorota ZAMORSKA-WOJDYŁA Zawartość rtęci i kadmu w strumieniu zużytych baterii cynkowo-węglowych typ R6, standard AA .....	405
Małgorzata WIDŁAK Ocena zawartości glinu wymiennego i wybranych parametrów gleb województwa świętokrzyskiego .....	413
Jerzy WIECZOREK i Paweł ZADROŻNY Zawartość kadmu, ołowiu i cynku w glebach bielicoziemnych Tatrzańskiego Parku Narodowego .....	421

Justyna ZIEMIAŃSKA, Paulina PAPLA, Wojciech BARAN Ewa ADAMEK, Andrzej SOBCZAK i Ilona LIPSKA Proces fotokatalityczny wybranych sulfonamidów w obecności $\text{TiO}_2$ , $\text{FeCl}_3$ i $\text{TiO}_2/\text{FeCl}_3$ .....	427
<b>Varia</b> .....	435
Invitation for ECOpole'13 .....	437
Zaproszenie na konferencję ECOpole'13 .....	439
Guide for authors .....	441
Zalecenia dla autorów .....	443

Papers

Artykuły



Wojciech BARAN<sup>1</sup>, Ewa ADAMEK<sup>1</sup>, Justyna ZIEMIAŃSKA<sup>2</sup>, Andrzej MAKOWSKI<sup>1</sup>  
and Andrzej SOBCZAK<sup>1,2</sup>

## ASSESSMENT OF SUSCEPTIBILITY OF SULFONAMIDE DRUGS TO BIODEGRADATION IN ENVIRONMENTAL SAMPLES

### OCENA PODATNOŚCI LEKÓW SULFONAMIDOWYCH NA BIODEGRADACJĘ W PRÓBKACH ŚRODOWISKOWYCH

**Abstract:** Sulfonamide drugs enter the environment in different ways, *eg* through wastewater, creating the potential risk of the generation of drug resistant strains of microorganisms. This risk increases when drugs are resistant to degradation and remain in the environment for a long time. Therefore, it is particularly important to know biodegradability of sulfa drugs since the literature data on this subject are often contradictory. In our study the estimation of susceptibility of four sulfonamides was carried out under aerobic and anaerobic conditions. The mixture of these compounds was added directly to environmental samples or natural wastewater samples (from different sources) or to synthetic wastewater containing inoculum from natural sources. The following effects were studied: aerobic/anaerobic conditions, the availability of light, initial concentrations, pH of the solution, sampling time of inoculum, earlier 40-days adaptation of inoculum to sulfanilamide. The effective biodegradation of sulfonamides was observed in 3 samples of sulfanilamide, 25 samples of sulfadiazine, 29 samples of sulfathiazole and 1 sample of sulfamethoxazole among the all investigated 86 samples. It was found that the biodegradation of sulfonamides differ significantly from the results presented in the literature. Moreover, the dynamics of this process depends mainly on the type of sulfonamide, the origin of inoculum and the sampling time.

**Keywords:** sulfonamides, pharmaceuticals, biodegradation

### Introduction

Sulfonamide drugs (SNs) can enter the environment in different ways, *eg* through wastewater, creating the potential risk of the generation of drug-resistant strains of microorganisms [1]. This risk increases when drugs are resistant to degradation processes and they remain in the environment for a long time.

Currently, particularly large amounts of SNs with bacteriostatic properties are used in animal husbandry and in aquaculture, often without restrictions. According to the data contained in the DANMAP report, the use of SNs to produce 1 kg of meat was from 0.0033 (broilers) up to 58.5 mg (farmed fish) [2]. Consequently, the concentration of SNs in manure of farmed animals may reach even 400 mg kg<sup>-1</sup> [1, 3]. However, more disquieting is the fact that in the environment the frequency of SNs in low concentrations is very high. Additionally, according to some researchers, the presence of SNs and other antibiotics was found in almost 100% of the tested surface water samples [1, 4].

According to majority of the researchers, SNs have been recognised as poor or non-biodegradable compounds in the environment (*ie*, in pure water, surface water and in soil) with a half life time > 30 days [1, 4-6]. The results of standardised tests, such as the ISO 11734:1995, OECD 301D, and the assessment of soil microbial activity suggest that

---

<sup>1</sup> Department of General and Inorganic Chemistry, The Faculty of Pharmacy and Division of Laboratory Medicine in Sosnowiec, The Medical University of Silesia, ul. Jagiellońska 4, 41-200 Sosnowiec, phone 32 364 15 62, email: bw-xxl@wp.pl

<sup>2</sup> Institute of Occupational Medicine and Environmental Health, ul. Kościelna 13, 41-200 Sosnowiec

most of SNs do not undergo natural biodegradation. In almost 40% of articles describing biological degradation of SNs, they are regarded as non-biodegradable compounds (in pure water, seawater, natural water and wastewater or active sludge) [1, 4, 5, 7-9]. The fact that SNs occur so frequently in the tested samples can also be considered as an evidence of their persistence in the environment.

The aim of our study was to evaluate the biodegradability of four SNs (*ie* sulfanilamide, sulfadiazine, sulfathiazole and sulfamethoxazole). The process was carried out directly in environmental samples or natural wastewater samples (originating from different sources), and in synthetic wastewater samples containing inoculum originating from natural sources. In particular, the following effects were studied:

- aerobic/anaerobic conditions,
- the availability of light ( $\lambda > 400$  nm),
- initial concentrations of SNs
- pH of the solutions,
- sampling time of inoculum,
- earlier, 40-days adaptation of inoculum to sulfanilamide.

## Methods

### Materials and samples

The appropriate amount of concentrated solution containing an equal-mass mixture of four SNs was added to the tested samples (Table 1).

Table 1

Characteristics of the studied SNs

Sulfonamides	CAS number	Abbr. in text	Manufacturer	$t_R^a$ [min]	LOD <sup>b</sup> [ $\mu\text{g dm}^{-3}$ ]
Sulfanilamide	63-74-1	SAD	POCH	5.45	3.0
Sulfamethoxazole	723-46-6	SMX	Sigma	7.49	4.3
Sulfadiazine	68-35-9	SDZ	Sigma	3.48	3.0
Sulfathiazole	72-14-0	STZ	Sigma	12.66	5.4

<sup>a)</sup> retention time for mobile phase flow  $1.0 \text{ cm}^3 \cdot \text{min}^{-1}$

<sup>b)</sup> limit of detection for injection samples at volume  $50 \text{ mm}^3$

Environmental samples were taken from the six selected sites (Table 2).

Table 2

The locations of the sampling sites

Samples	Locations (latitude;longitude)
Influent, municipal wastewater	50,304897;19,204884
Effluent from WWTP	50,301577;19,202357
Water from a pond	50,342982;19,186119
Landfil leachate	50,375125;19,058443
Septic tank	50,371016;19,038153
Manure from cattle	50,294891;19,908038

Only in one experiment, the pH of sample was corrected by addition of HCl solution.

Additionally, synthetic wastewaters were used as the reaction medium [10] and the inoculum from environmental samples were also added to these wastes (1 ml inoculum was added to 100 ml of wastewater). Environmental samples were used within 2 days after collection. Only in one experiment, wastewater from septic tank was stored frozen at  $-18^{\circ}\text{C}$  for 40 days.

In order to adapt of microorganisms to SNs, 50 g of SAD was added to dual-chamber septic tank with a capacity of  $10\text{ m}^3$ . The samples were taken before SDA addition and after 40 days.

### Apparatus

After intensive stirring, the samples were put in the reaction set (for minimum period of 28 days) as shown in Figure 1.

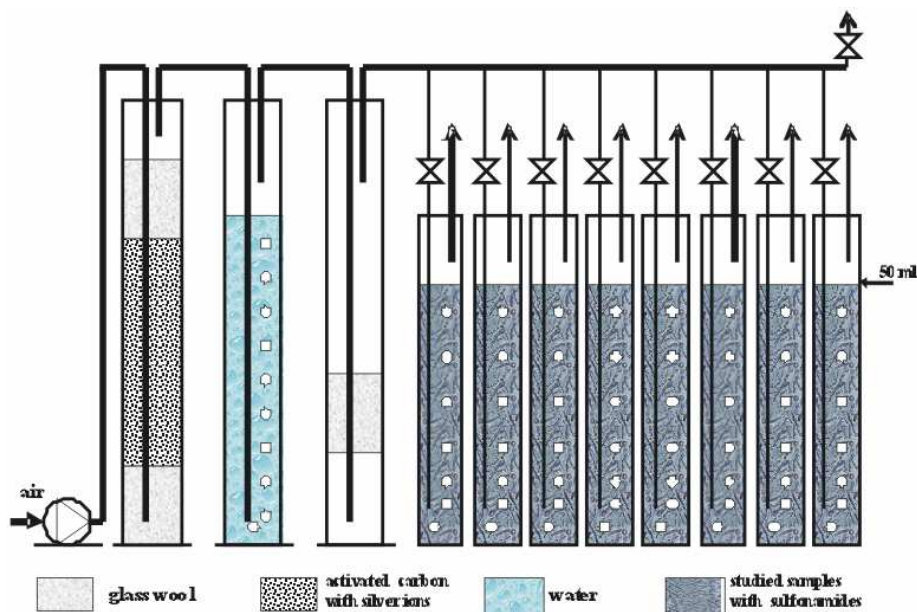

Fig. 1. Scheme of the reactors for aerobic biodegradation

Under aerobic conditions, the air flow rate in the reactors was in the range of  $\sim 5\text{ cm}^3\text{ min}^{-1}$  (oxygen saturation  $> 90\%$ ), the temperature  $20.4 \pm 0.5^{\circ}\text{C}$ , the light intensity  $< 10\text{ W m}^{-2}$  ( $< 1\%$  of UV irradiation). Additionally, the experiments in the dark and under anaerobic conditions were carried out.

### Analysis

The degree of degradation was determined as the relative decrease in the concentration of each SNs in samples after a definite reaction time. A possible sorption of SNs on

suspended sediments particles of samples was omitted (it was regarded as insignificant based on an analysis of the literature data [9]). The SNs concentrations were determined by HPLC method (detector - Waters TAD 486,  $\lambda = 254$  nm; pump - Knauer 64, flow -  $1.0 \text{ cm}^3 \cdot \text{min}^{-1}$ ; column - Supelcosil LC-18,  $5 \mu\text{m}$ ;  $250 \times 4.6$  mm; mobile phase - buffer containing  $20 \text{ mmol dm}^{-3} \text{ K}_2\text{HPO}_4$  at  $\text{pH} = 8.2$  : acetonitrile, 95:5). The time required to reduce the SNs concentrations by 25% ( $T_{0.25}$ ) was determined by the graphical method.

## Results and discussion

The decrease the SNs concentration was observed in the test samples. Figure 2 shows the dynamics of this process.

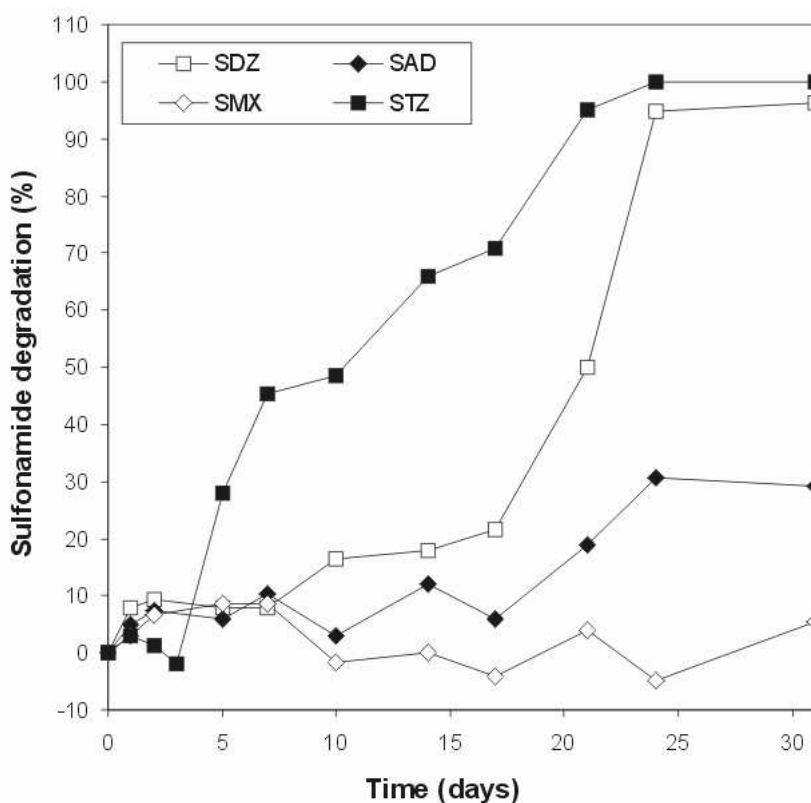

Fig. 2. The relationship between the type of SN and the dynamics of its biodegradation (aerobic conditions; synthetic wastewater inoculated with manure; 08.06.2010;  $C_0 = 10 \text{ mg dm}^{-3}$ )

It was found that the biodegradation rate was mainly dependent on the type of SN. Moreover, the observed processes did not follow precisely first-order kinetics. In all experimental samples, a decrease in SNs concentrations (probably as a result of sorption) was observed after the first 2-3 days. After that time, their concentration (except STZ) did



not undergo significant changes for a longer time. SMX was the only one among SNs that practically did not undergo the biodegradation processes under these conditions. The effective SNs biodegradation was observed in 3 samples of SAD, 25 samples of SDZ, 29 samples of STZ and only in 1 sample of SMX among all the 86 samples investigated. A factor having a significant effect on the results obtained was also the origin of the inoculum. Figure 3 shows the effect of inoculum type on the  $T_{0,25}$  value.

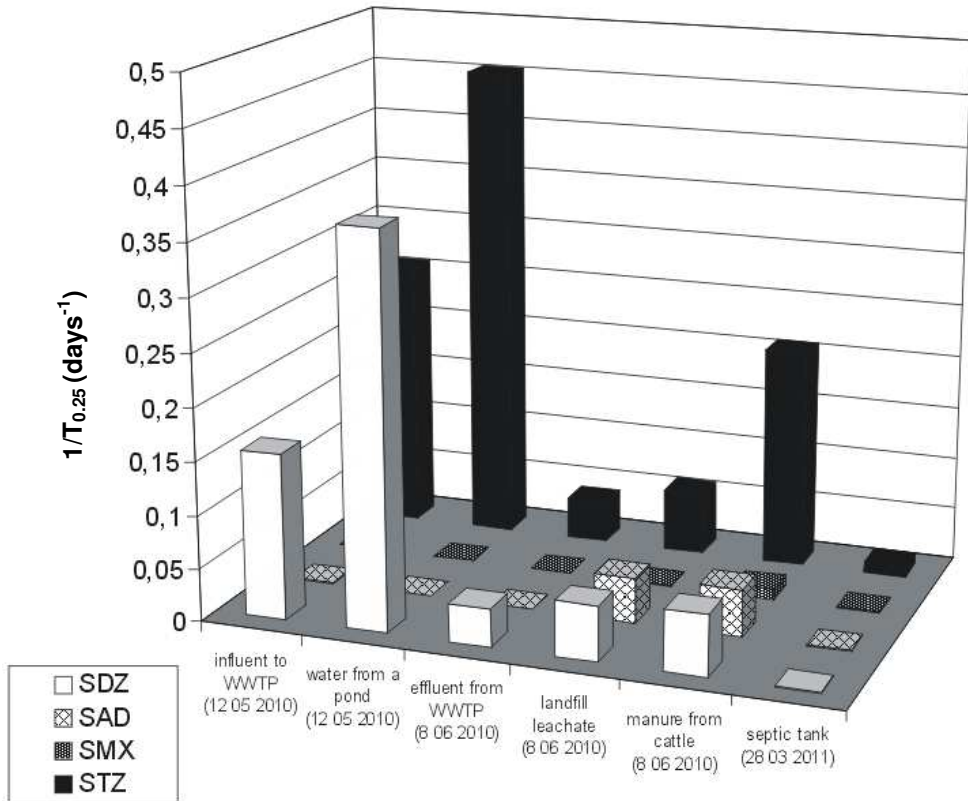

Fig. 3. The relationship between the inoculum type and the biodegradation rate of SNs (aerobic conditions; inoculated synthetic wastewater,  $C_o = 10 \text{ mg dm}^{-3}$ )

These results are qualitatively consistent with those obtained during the direct biodegradation in environmental samples. The biodegradation rate of STZ and SDZ in water from a pond turned out to be unexpectedly high. Contrary, these drugs were very slow biodegraded in wastewater from septic tanks. In the first case, the effect may be associated with the possible earlier illegal use of antibiotics by anglers. Such action could theoretically lead to the adaptation of microorganisms. In order to confirm this assumption, we conducted an experiment with wastewater adapted to SNs (*materials and samples*). The obtained results did not differ from those shown in Figure 4. It is possible that the low biodegradation rate in samples from septic tank is due to their prior freezing.

In the case of samples collected from one source, a significant effect on the biodegradation rate may also have the sampling time (Fig. 4).

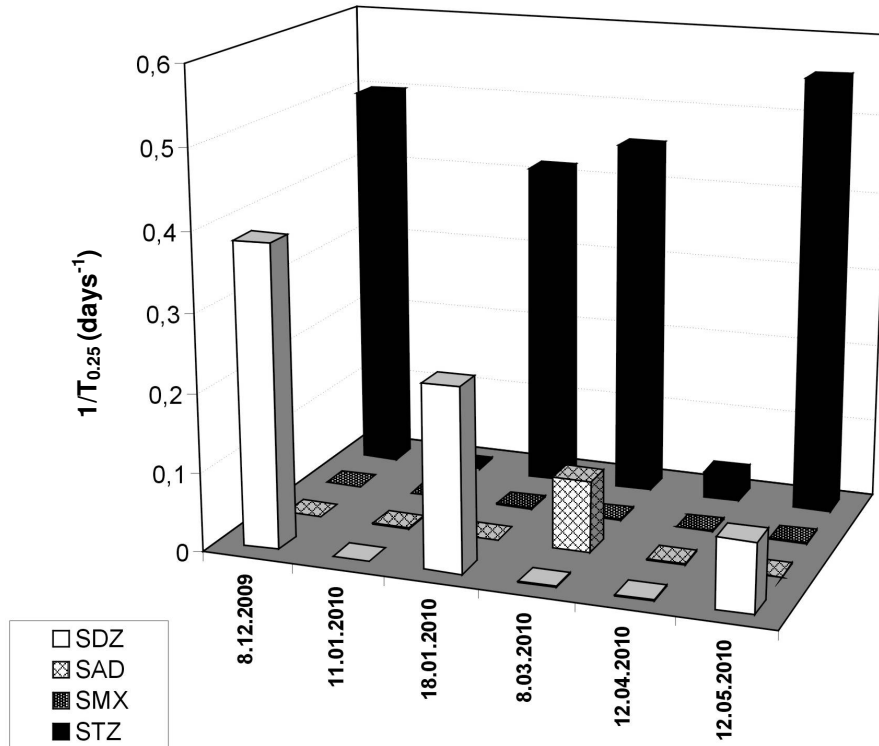

Fig. 4. The relationship between day of sampling and the biodegradation rate of SNs (aerobic conditions; natural influent, natural pH,  $C_o = 10 \text{ mg} \cdot \text{dm}^{-3}$ )

In our opinion, the weather conditions during the collection of influent may be essential to explain the obtained results. For example, just before 11.01.2010 the temperature was about  $0^\circ\text{C}$ , it was freezing rain and melting snow, the streets were intensively sprinkled with a salt-ice mixture. As a result, municipal wastewater containing runoff from the streets may be poor in microorganisms. These weather conditions were not repeated at any other sampling time (a minimal rainfall was observed only on 04.11.2010) [11].

A large dependence on the sampling time was found in samples collected from the pond. In synthetic wastewater inoculated by a sample collected in spring, the  $T_{0.25}$  values for STZ and SDZ were 2.2 and 2.7 days, respectively. In the sample taken from under ice in winter (20.12.2010), there was no degradation of SNs within 28 days.

Additionally, the relationships between pH (Fig. 5) and the initial concentration of SNs in wastewater (Fig. 6) on the biodegradation rate were determined.

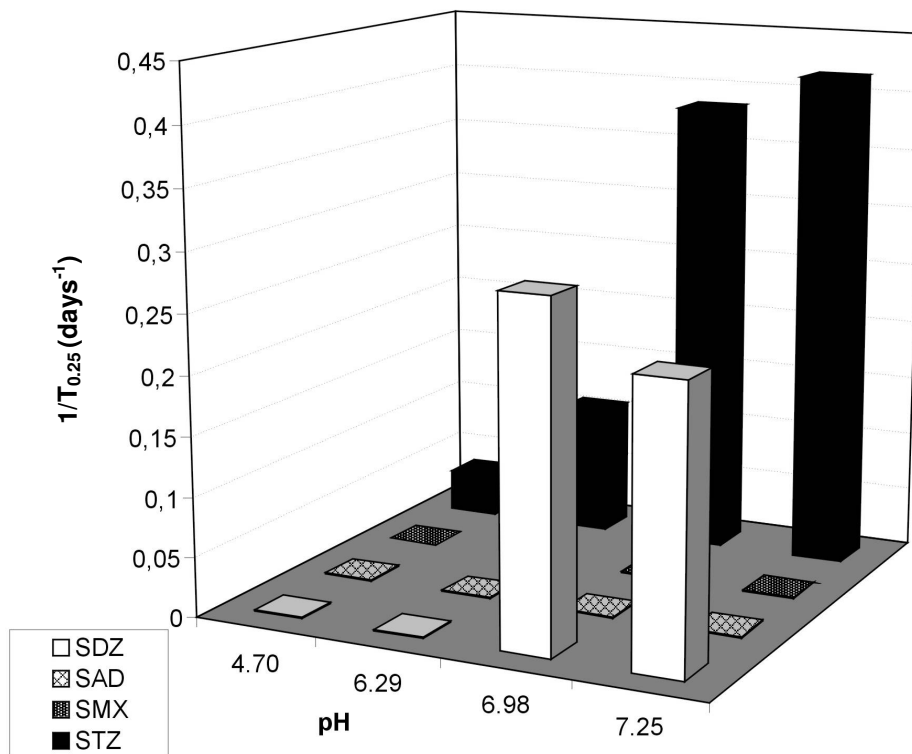

Fig. 5. Effect of pH on the biodegradation rate of SNs (aerobic conditions, natural influent; 18.01.2010;  $C_o = 10 \text{ mg dm}^{-3}$ )

It was found that the decrease in pH values below  $\sim 7$  caused an inhibition of SNs biodegradation and in acidic samples ( $\text{pH} < 4.7$ ) the process practically did not occur.

However, it can not be excluded that the results in naturally acidic environmental samples might be different from these obtained in our experiments.

From the viewpoint of biodegradation rate of SNs, their optimal concentrations in the used wastewater were in the range of  $2\text{--}4 \text{ mg dm}^{-3}$ . It is not excluded that these values will be different for other samples. Therefore, the optimal concentrations of SNs during their biodegradation in wastewater samples may also depend on the sensitivity of microorganisms occurring in the reaction medium.

The results of experiments suggest also that aeration of samples has a beneficial effect on the SNs biodegradation. In influent (sampling time: 08.12.2009) the  $T_{0.25}$  values for SDZ and STZ were 2.2 and 2.7 days under aerobic conditions and  $> 28$  and 3.3 days under anaerobic conditions, respectively.

Additionally, there was no significant effect of:

- short-term adaptation of microorganisms to SNs and,
- exposure to low light intensity.

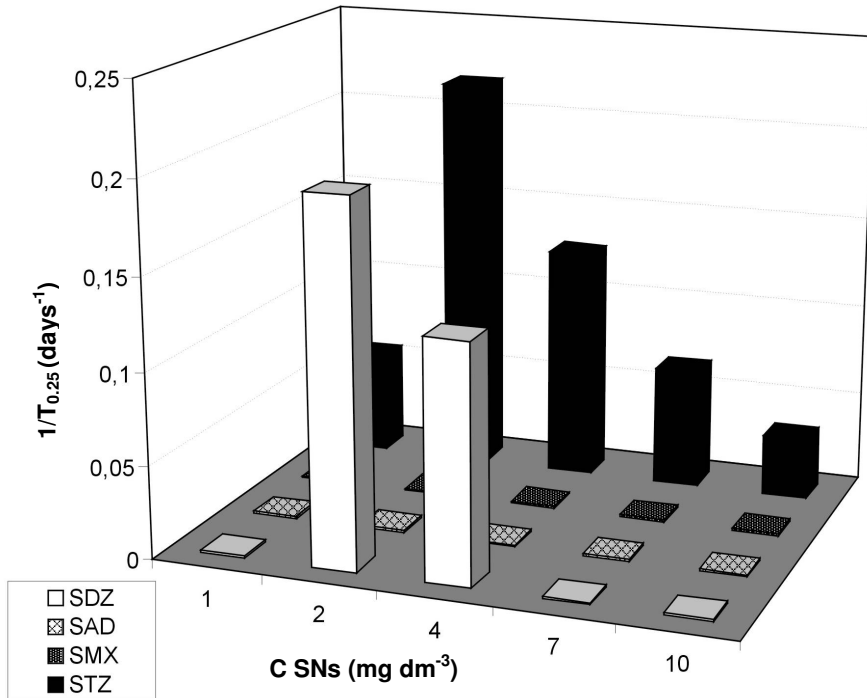

Fig. 6. The relationship between the SNs concentration and their biodegradation rate (aerobic conditions; natural influent, 12.04.2010, natural pH)

### Conclusions

- The individual SNs may differ significantly from each other.
- Anaerobic, poor in microorganisms or acidic conditions do not favor the rapid biodegradation of SNs.

### Acknowledgements

This work was supported by Medical University of Silesia in Katowice (Poland), contract No. KNW-1-056/P/1/0.

### References

- [1] Baran W, Adamek A, Ziemiańska J, Sobczak A. *J Hazard Mater.* 2011;196:1-15. DOI: 10.1016/j.jhazmat.2011.08.082.
- [2] DANMAP, Use of antimicrobial agents and occurrence of antimicrobial resistance in bacteria from food animals, foods and humans in Denmark, 2009, available at: [http://www.danmap.org/pdfFiles/Danmap\\_2009.pdf](http://www.danmap.org/pdfFiles/Danmap_2009.pdf).
- [3] De Liguoro M, Poltronieri C, Capolongo F, Montesissa C. *Chemosphere.* 2007;68:671-676. DOI: 10.1016/j.chemosphere.2007.02.009.

- [4] Eintrag von Arzneimitteln und deren Verhalten und Verbleib in der Umwelt, Literaturstudie Fachbericht 2, Landesamt für Natur, Umwelt und Verbraucherschutz Nordrhein-Westfalen, Recklinghausen, 2007, available at: <http://www.lanuv.nrw.de/veroeffentlichungen/fachberichte/fabe2/lanuvfabe2.pdf>.
- [5] Onesios KM, Yu JT, Bouwer EJ. Biodegradation. 2009; 20:441-466. DOI: 10.1007/s10532-008-9237-8.
- [6] Environmentally Classified Pharmaceuticals, Stockholm County Council, 2009, available at: <http://www.janusinfo.se/environment>.
- [7] Halling-Sørensen B, Nors Nielsen S, Lanzky PF, Ingerslev F, Holten Lützhof HC, Jørgensen SE. Chemosphere. 1998;36:357-393. DOI: 10.1016/S0045-6535(97)00354-8.
- [8] Baran W, Sochacka J, Wardas W. Chemosphere. 2006;65:1295-1299. DOI: 10.1016/j.chemosphere.2006.04.040.
- [9] Yang S-F, Lin C-F, Lin AY-C, Hong P-KA. Water Res. 2011;45:3389-3397. DOI: 10.1016/j.watres.2011.03.052.
- [10] Rozporządzenie Ministra Środowiska z dnia 6 listopada 2002 r. w sprawie metodyk referencyjnych badania stopnia biodegradacji substancji powierzchniowo czynnych zawartych w produktach, których stosowanie może mieć wpływ na jakość wód. (Dz.U.02.196.1658 z dnia 26 listopada 2002 r.).
- [11] Weatheronline, available at: [http://www.weatheronline.pl/weather/maps/city?WEEK=04&MM=04&YY=2010&WMO=12566&LANG=pl&SID=12566f96311804070c5f3caa1df46b65dd6f7a&ART=PRE&CONT=euro&R=150&NOREGION=1&LEVEL=150&REGION=0001&LAND=\\_\\_%29\)](http://www.weatheronline.pl/weather/maps/city?WEEK=04&MM=04&YY=2010&WMO=12566&LANG=pl&SID=12566f96311804070c5f3caa1df46b65dd6f7a&ART=PRE&CONT=euro&R=150&NOREGION=1&LEVEL=150&REGION=0001&LAND=__%29)).

## OCENA PODATNOŚCI LEKÓW SULFONAMIDOWYCH NA BIODEGRADACJĘ W PRÓBKACH ŚRODOWISKOWYCH

<sup>1</sup> Zakład Chemii Ogólnej i Nieorganicznej, Wydział Farmaceutyczny z Oddziałem Medycyny Laboratoryjnej w Sosnowcu, Śląski Uniwersytet Medyczny

<sup>2</sup> Instytut Medycyny Pracy i Zdrowia Środowiskowego w Sosnowcu

**Abstrakt:** Leki sulfonamidowe, trafiając do środowiska, powodują ryzyko polegające na generowaniu lekooporności drobnoustrojów. Ryzyko to wzrasta w przypadku odporności tych leków na rozkład i pozostawania w środowisku przez dłuższy czas. Z tego powodu szczególnie ważne jest poznanie ich podatności na biodegradację, a dane zawarte w literaturze są rozbieżne. W trakcie badań dokonano oceny podatności na biodegradację 4 sulfonamidów (sulfanilamidu, sulfadiazyny, sulfatiazolu i sulfametoksazolu). Mieszaninę tych sulfonamidów wprowadzano bezpośrednio do próbek środowiskowych lub naturalnych ścieków pochodzących ze zróżnicowanych źródeł i do ścieków syntetycznych zawierających inokulum przygotowane z naturalnych źródeł. Określono, jaki wpływ na przebieg biodegradacji mają warunki tlenowe prowadzenia procesu, dostępność światła ( $\lambda > 400$  nm), stężenie degradowanej substancji, pH roztworu, pora roku, w jakiej pobierano inokulum, oraz wcześniejsza 40-dniowa adaptacja inokulum w obecności sulfanilamidu. Stopień degradacji sulfonamidów oceniano na podstawie obniżenia ich stężenia oznaczonego metodą HPLC w ciągu 28 dni. Stwierdzono, że na 86 badanych próbek efektywną biodegradację sulfonamidów ( $T_{1/2} < 21$  dni) obserwowano odpowiednio: sulfanilamid - 3 próbki, sulfadiazyna - 25 próbek, sulfatiazol - 29 próbek i sulfametoksazol - 1 próbka. Stwierdzono również, że przebieg biodegradacji sulfonamidów znacznie różni się od wyników opisywanych w literaturze, a jego dynamika zależy głównie od rodzaju sulfonamidu, pochodzenia inokulum i pory roku jego pozyskania.

**Słowa kluczowe:** sulfonamidy, farmaceutyki, biodegradacja



Krzysztof BARBUSIŃSKI<sup>1</sup>, Magdalena AMALIO-KOSEL<sup>1</sup>, Barbara PIECZYKOLAN<sup>1</sup>  
Izabela PŁONKA<sup>1</sup> and Sławomir FAJKIS<sup>2</sup>

## STUDIES OF OPTIMIZATION OF COLORED WASTEWATER TREATMENT BY FENTON'S REAGENT (PART I)

### BADANIA W CELU OPTYMALIZACJI OCZYSZCZANIA ŚCIEKÓW BARWNYCH ODCZYNNIKIEM FENTONA (CZĘŚĆ I)

**Abstract:** The constant industry development results in the increase of number and diversity of substances deposited with wastewater. Moreover, requirements for wastewater utilization are constantly restricted, thus there is the need of treatment methods improvement. In recent studies significant attention is devoted to advanced oxidation processes (AOPs), in which highly reactive radicals able to treat concentrated, hardly degradable and toxic industrial wastewaters are generated. Colored wastewaters produced during industrial processes usually characterize with significant content of refractive organic compounds which additionally possess mutagenic and cancerogenic properties. Classical treatment methods of such wastewaters (e.g. sorption, coagulation) hardly ever guarantee efficient dyes degradation. Thus, the treatment of colored wastewater with the use of one of AOP i.e. Fenton reagent was performed. First, preliminary studies focused on the influence of H<sub>2</sub>O<sub>2</sub> dose, initial pH value, reaction time and Fe<sup>2+</sup>/H<sub>2</sub>O<sub>2</sub> weight ratio on treatment effect were performed. Obtained results will be further used for development of crucial studies plan in which Surface Response Method will be used. The study will allow to formulate mathematical models describing changes of wastewater decolorization effects as a function of investigated parameters. Thus, the optimization of the process will be possible.

**Keywords:** advanced oxidation processes, Fenton's reagent, dye wastewater, response surface methodology

### Introduction

One of the results of the civilization development is the global application of organic dyes applied in many branches of the industry. Nowadays almost all produced goods - including food, cosmetic products, pharmaceuticals, plastics, textiles or even natural material are dyed. Colored wastewaters produced during technological processes characterize with significant content of hardly decomposing organic compounds, which possess toxic or cancerogenic properties. Thus, the degradation of dyes must be performed in order not only to protect water ecosystems but also humans' health and safety [1-3].

According to wide diversity of dyes used in industry there are many treatment technologies applied for removal of those contaminants. It includes coagulation, sorption, chemical oxidation with ozone or hydrogen peroxide or separation. In many cases combination of those processes together with biological treatment is applied [1, 4-7]. Advanced oxidation processes (AOPs) i.e. UV/H<sub>2</sub>O<sub>2</sub> [1], UV/TiO<sub>2</sub> [8] or Fenton reagent are also a solution used for colored wastewater treatment. The high effectiveness of those processes is obtained by the action of highly reactive hydroxyl free radicals OH<sup>•</sup>. Those radicals characterize with significant redox potential (2.8 V) as well as fast and non-selective oxidation of many organic compounds. However, many scientists state that in case of Fenton reaction ferryl ion (FeO<sup>2+</sup>) acts as an oxidizing agent [4].

<sup>1</sup> Faculty of Energy and Environmental Engineering, The Silesian University of Technology, ul. S. Konarskiego 18A, 44-100 Gliwice, phone 32 237 28 49, email: magdalena.amalio-kosel@polsl.pl

<sup>2</sup> Zakłady Tuszczowe „Bielmar” Sp. z o.o., ul. S. Sempolowskiej 63, 43-300 Bielsko-Biała

The application of Fenton method for contaminants degradation has many advantages *ie* no toxic effect, low price of reagent components and no formation of chloroorganic compounds. The evaluation of treatment of wastewater containing Acid Yellow 36 dye by means of Fenton method is discussed in the presented paper. The results obtained during the study will be a base for further treatment via *Surface Response Method*. The second part of the study will focus on the development of mathematical models describing changes of wastewater decolorization effects as a function of investigated parameters. Thus, the optimization of the process will be possible.

### Methodology of the study

The treatment of colored wastewater containing acidic dye Acid Yellow 36 extra (250%) by BORUTA-KOLOR Sp. z o.o. was performed. The dye is mainly used in textile industry and according to its properties it must be removed from wastewaters before their deposition to the receiving body [9]. The aim of the experiment was to determine the influence of  $\text{H}_2\text{O}_2$  dose, initial pH, reaction time and weight ratio of  $\text{Fe}^{2+}/\text{H}_2\text{O}_2$  on wastewater decolorization effects. The synthetic wastewater was prepared via dissolution of 100 mg of dye in 1 dm<sup>3</sup> of deionized water. The obtained solution characterized with yellow color and clarity. Next, the solution was acidified until the desired pH was established. Next, hydrogen peroxide and solid  $\text{FeSO}_4 \cdot 7\text{H}_2\text{O}$  were added. Fenton reaction occurs in acidic environment and after it is finished, the neutralization was needed. The wastewater neutralization caused their further decolorization and precipitation of well-settling iron(III) hydroxide  $\text{Fe}(\text{OH})_3$ . The degradation of dye was carried out in beakers of 1 dm<sup>3</sup> volume which were constantly mixed using magnetic stirrer with the speed of 300 rpm. The determination of dye concentration in treated wastewater was made after their neutralization and centrifugation (used to remove formed precipitate) by means of absorbance measurements using SPEKOL UV VIS spectrometer at wavelength  $\lambda = 485$  nm. The visual evaluation of decolorization rate was also made.

### Results and discussion

In the preliminary studies hydrogen peroxide doses in the range 40÷200 mg/dm<sup>3</sup> increased by 20 mg/dm<sup>3</sup> step-wisely were applied. The first part of experiments was carried out at constant pH = 3.5 and  $\text{Fe}^{2+}/\text{H}_2\text{O}_2$  weight ratio equal to 0.33. Basing on previous studies performed at Division of Water and Wastewater Technology 15 and 30 min reaction times were accepted. Obtained results revealed that the increase of hydrogen peroxide dose caused the decrease of absorbance value at treated wastewater (Fig. 1). The visual decolorization was already obtained for the oxidant dose equal to 140 mg/dm<sup>3</sup> for which absorbance value was at the level of 0.078. The best degradation effect was noted for the oxidant dose equal to 180 mg  $\text{H}_2\text{O}_2/\text{dm}^3$ . In the next stage of the study the decolorization effectiveness at constant pH = 3.5,  $\text{H}_2\text{O}_2$  dose - 180 mg  $\text{H}_2\text{O}_2/\text{dm}^3$  and various  $\text{Fe}^{2+}/\text{H}_2\text{O}_2$  weight ratios in the range 0.05-0.5 was investigated. The reaction times were also equal to 15 and 30 min. The best treatment effect was obtained for  $\text{Fe}^{2+}/\text{H}_2\text{O}_2$  ratios 0.05 and 0.1 (measured absorbance values after 15 min were equal to 0.1216 and 0.0714 and after 30 min 0.0674 and 0.0648, respectively).



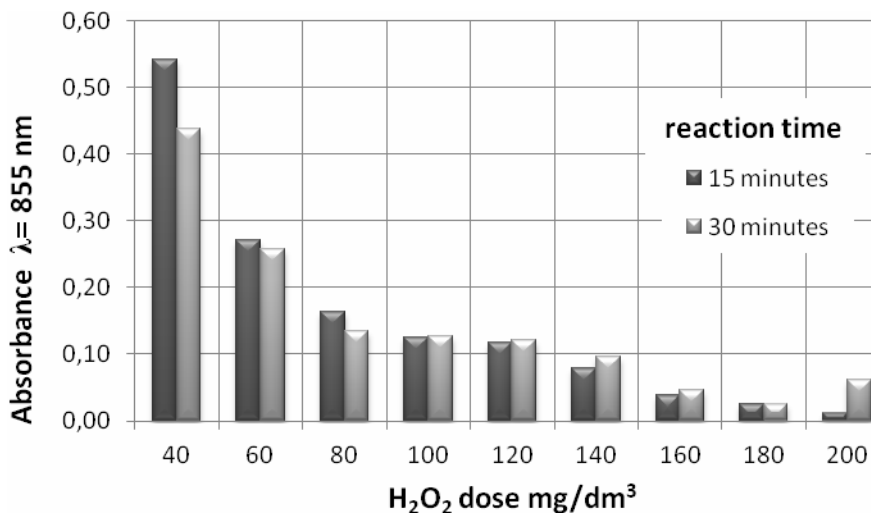

Fig. 1. The influence of H<sub>2</sub>O<sub>2</sub> dose on the decolorization effect for the following process parameters: mass ratio of Fe<sup>2+</sup>/H<sub>2</sub>O<sub>2</sub> = 0.33; pH = 3.5

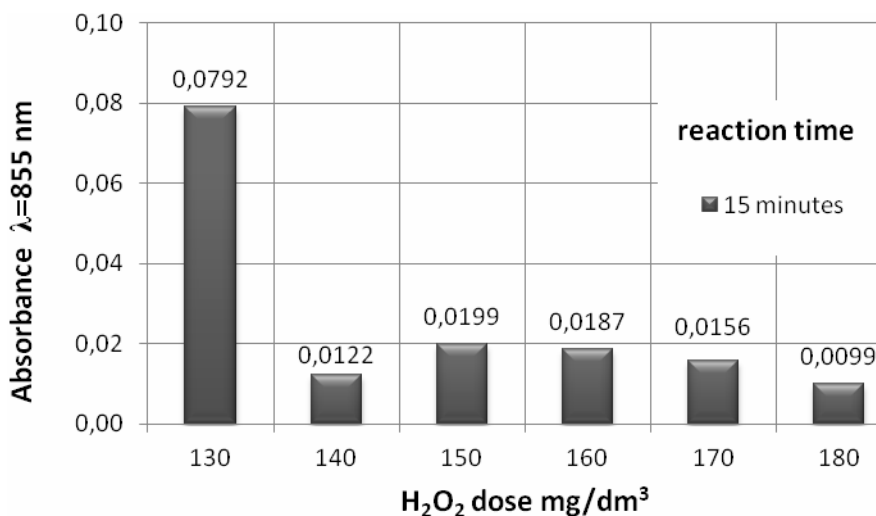

Fig. 2. The influence of H<sub>2</sub>O<sub>2</sub> dose on the decolorization effect for the following process parameters mass ratio of Fe<sup>2+</sup>/H<sub>2</sub>O<sub>2</sub> = 0.1; pH = 3.5

The next study step was to investigate the influence of the initial pH value on Acid Yellow 36 dye degradation. The applied pH values were equal to 2, 2.5 and 3.5. Other process conditions *ie* H<sub>2</sub>O<sub>2</sub> dose and Fe<sup>2+</sup>/H<sub>2</sub>O<sub>2</sub> weight ratios were equal to 180 mg/dm<sup>3</sup>, and 0.05 and 0.1, respectively. The analysis of obtained results caused the modification of process conditions. Thus, the effect of decolorization at pH = 3.5, Fe<sup>2+</sup>/H<sub>2</sub>O<sub>2</sub> weight ratio

0.1 and the oxidant dose range 130-180 mg/dm<sup>3</sup> was investigated (Fig. 2). The visual decolorization was obtained for H<sub>2</sub>O<sub>2</sub> doses above mg/dm<sup>3</sup>.

On the basis of obtained results optimal conditions of classical Fenton reaction were established *ie* oxidant dose = 140 mg/dm<sup>3</sup>, Fe<sup>2+</sup>/H<sub>2</sub>O<sub>2</sub> weight ratio 0.1, pH = 3.5, and reaction time 15 min. Nevertheless, the final stage of the study was focused on the influence of reaction time on process effectiveness. The study of reaction kinetic revealed that visual decolorization could be obtained already after 7 minutes for which absorbance value was equal to 0.0904 (Table 1).

Table 1

The influence of reaction time on the decolorization effect

Dose of H <sub>2</sub> O <sub>2</sub> = 140 Mass ratio of Fe <sup>2+</sup> /H <sub>2</sub> O <sub>2</sub> = 0.1 pH = 3.5		
Reaction time [min]	Post-neutralization color	Absorbance
1	Intensive yellow	0.7173
2	Light yellow	0.4052
3	Light bright yellow	0.1933
4	Light bright yellow	0.1323
5	Light bright yellow	0.1168
7	Visual decolorization	0.0904
10	Visual decolorization	0.0899
12	Visual decolorization	0.0833
15	Visual decolorization	0.0822
20	Visual decolorization	0.0835
25	Visual decolorization	0.0875
30	Visual decolorization	0.0885

## Conclusion

The study revealed that degradation Acid Yellow 36 degradation can be made using Fenton reagent. At proper process conditions visual decolorization can be obtained after 7 minutes of reaction run. The effectiveness of the wastewater treatment is also depended on the oxidant dose and Fe<sup>2+</sup>/H<sub>2</sub>O<sub>2</sub> weight ratio optimal values of which are established at 140 mg/dm<sup>3</sup> and 0.1. The process environment should be acidified up to pH = 3.5 and during a further research check the effect of decolorization of sewages for higher pH values.

The proposed treatment method is easy to perform, however one must remember about post-process neutralization of wastewater. Additionally, the alkalization of wastewater also improves the decolorization effect. The presented studies allow to generate the plan for further investigations focused on optimization of treatment of wastewater containing Acid Yellow 36 using Fenton reagent.

## References

- [1] Santos VP, Pereira MFR, Faria PCC, Orfao JJM. Decolourisation of dye solutions by oxidation with H<sub>2</sub>O<sub>2</sub> in the presence of modified activated carbons. J Hazard Mater. 2009;162(2-3):736-742.
- [2] Khorramfar S, Mahmoodi NM, Arami M, Gharanjig K. Equilibrium and kinetic studies of the cationic dye removal capability of a novel biosorbent *Tamarindus indica* from textile wastewater. Coloration Technol. 2010;126(5):261-268.

- [3] Shooka K, Mohammad MN, Mokhtar A, Hajir B. Oxidation of dyes from colored wastewater using activated carbon/hydrogen peroxide. *Desalination*. 2011; 279(1-3):183-189.
- [4] Barbusiński K, Pieczykolan B. Wstępne badania degradacji barwnika Acid Green 16 w systemie  $H_2O_2$ /wiórki stalowe. *Inż Ochr Środow*. 2009;12(1):35-49.
- [5] Faria PCC, Orfao JJM, Pereira MFR. Mineralisation of coloured aqueous solutions by ozonation in the presence of activated carbon. *Water Res*. 2005;39(8):1461-1470.
- [6] Robinson T, McMullan G, Marchant R, Nigam P. Remediation of dyes in textile effluent: a critical review on current treatment technologies with a proposed alternative. *Bioresource Technol*. 2001;77(3):247-253.
- [7] Jiraratananon R, Sungpet A, Luangsowan P. Performance evaluation of nanofiltration membranes for treatment of effluents containing reactive dye and salt. *Desalination*. 2000;130(2):177-183.
- [8] Tang C, Chen V. The photocatalytic degradation of reactive black 5 using  $TiO_2$ /UV in an annular photoreactor. *Water Res*. 2004;38(11):2775-2781.
- [9] Karta charakterystyki barwnika Acid Yellow 36. Zakłady Boruta-Kolor w Zgierzu.

## BADANIA W CELU OPTYMALIZACJI OCZYSZCZANIA ŚCIEKÓW BARWNYCH ODCZYNNIKIEM FENTONA (CZĘŚĆ I)

<sup>1</sup> Wydział Inżynierii Środowiska i Energetyki, Politechnika Śląska, Gliwice

<sup>2</sup> Zakłady Tłuszczowe „Bielmar” Sp. z o.o., Bielsko-Biała

**Abstrakt:** W wyniku ciągłego rozwoju przemysłu wzrasta ilość i różnorodność zanieczyszczeń odprowadzanych ze ściekami. Ponadto wymagania dotyczące unieszkodliwiania ścieków ulegają ciągłym zaostreżeniom, dlatego istnieje duża potrzeba doskonalenia metod oczyszczania. W ostatnich latach dużą uwagę poświęca się badaniom i wdrażaniu tzw. metod pogłębionego utleniania, które polegają na generowaniu wysoko reaktywnych rodników mających zdolność oczyszczania stężonych, trudno degradowanych i toksycznych ścieków przemysłowych. Ścieki barwne powstające w wyniku procesów produkcyjnych zazwyczaj charakteryzują się dużą zawartością trudno rozkładalnych związków organicznych, mających często charakter muta- i kancerogenny. Klasyczne metody oczyszczania takich ścieków (np. koagulacja, sorpcja) rzadko umożliwiają skuteczną degradację barwników, dlatego przeprowadzono oczyszczanie ścieków barwnych, wykorzystując jedną z metod pogłębionego utleniania - odczynnik Fentona. W pierwszej kolejności przeprowadzono badania wstępne, mające na celu określenie wpływu wielkości dawki  $H_2O_2$ , początkowej wartości pH, czasu reakcji oraz wartości stosunku masowego  $Fe^{2+}/H_2O_2$  na efekty odbarwienia ścieków. Uzyskane w ten sposób wyniki były następnie podstawą do opracowania planu badań właściwych, prowadzonych przy użyciu tzw. metody powierzchni odpowiedzi. Na podstawie wyników tych badań opracowane zostaną modele matematyczne zmian efektów odbarwienia ścieków w funkcji badanych czynników, umożliwiające przeprowadzenie optymalizacji tego procesu.

**Słowa kluczowe:** metody pogłębionego utleniania (AOPs), odczynnik Fentona, ścieki barwne, metoda powierzchni odpowiedzi



Wojciech BIERZA<sup>1</sup>, Aleksandra NADGÓRSKA-SOCHA<sup>1</sup>, Elżbieta MAŁKOWSKA<sup>1</sup>  
and Ryszard CIEPAŁ<sup>1</sup>

## EVALUATION OF THE SOIL ENZYMES ACTIVITY AS AN INDICATOR OF THE IMPACT OF ANTHROPOGENIC POLLUTION ON THE NORWAY SPRUCE ECOSYSTEMS IN THE SILESIA BESKID

### OCENA AKTYWNOŚCI ENZYMÓW GLEBOWYCH JAKO WSKAŹNIKA WPŁYWU ZANIECZYSZCZEŃ ANTROPOGENNYCH NA FUNKCJONOWANIE EKOSYSTEMÓW LASÓW ŚWIERKOWYCH BESKIDU ŚLĄSKIEGO

**Abstract:** Activity of soil enzymes is considered as a good indicator of natural and anthropogenic disturbances of the functioning of the soil. Heavy metals can inhibit the activity of enzymes in varying degree, depending on soil properties such as content of clay materials, organic matter and pH of soil solution. The aim of this study was to determine the effect of physicochemical and biological properties of soils on the condition of Norway spruce stands in Silesian Beskid. In the soil samples enzymatic activity of four enzymes (alkaline and acid phosphatase, dehydrogenase and urease) and concentration of three selected heavy metals (Cd, Pb, Zn) and sulfur were determined. The analyses showed no reduced activity of investigated enzymes. Presumably, despite of low pH values of the soil, organic matter contained in the soil is able to effectively bind heavy metal ions, limiting their cycling in the environment. It can be concluded that the condition of spruce stands in Silesian Beskid is not affected by the soil contamination.

**Keywords:** heavy metals, soil enzymes, Norway spruce, Silesian Beskid

#### Introduction

Biological processes influencing soil fertility in terrestrial ecosystems are mainly based on the transformation of organic matter [1]. Evaluation of the quality and the productivity of the soil is an important part in the study of the natural environment. In temperate forest ecosystems, dominated by Ectomycorrhizal trees, acid soils accumulating large quantities of organic molecules are predominant. Forest soil fertility and productivity of the forest ecosystems depend on the activity of biochemical processes in the soils, which are catalyzed by enzymes secreted into the soil environment mainly by soil microorganisms [2-4]. Enzymes such as urease usually serve as an index of the soil fertility because their activity correlates with the organic matter content in soil, alkaline and acid phosphatase, which are closely associated with respiratory and biomass of soil organisms, and the dehydrogenase which is an excellent indicator of respiratory activity of soil microorganisms [4, 5]. The activity of soil enzymes is considered as a good bioindicator which reflects the natural and anthropogenic disturbance of the soil [6, 7]. Soil enzymes are inhibited by heavy metals to varying degrees, depending on properties of the soil, such as the contents of clay materials and organic matter, or pH value of a soil solution [8-10]. The object of the studies on the soil enzymes activity and the contamination of soil with heavy metals and

---

<sup>1</sup> Faculty of Biology and Environmental Protection, University of Silesia in Katowice, ul. Bankowa 9, 40-007 Katowice, phone 32 359 11 18, email: wbierza@us.edu.pl

sulfur was to determine the soil condition of Silesian Beskid and estimate the possible impact of these factors on the weakening of the spruce stands in these mountains.

### **Material and methods**

The material for the analysis was being collected from September to October 2007. Six mountain peaks of the Silesian Beskid have been investigated: Blatnia, Klimczok, Skrzyczne, Soszow, Stozek and Szyndzielnia. Soil samples for the analysis were taken from following depths: 0-10, 10-20 and 20-30 cm [11], from five selected points in the entire area of the peak. Soil samples were mixed for each depth and each amount separately.

Soil was sifted through a sieve with a diameter of 1 mm and dried to a constant weight, upon which 10 g subsamples from each depth and each uphill were prepared. Soil subsamples were inserted into 100 cm<sup>3</sup> of 10% nitric acid(V) and shaken for one hour. After that the subsamples were filtered. Concentration of three heavy metals (contamination fraction), zinc, cadmium and lead were determined on an atomic absorption spectrometer [12]. Bioavailable fraction of heavy metals in soil samples was determined with similar depth, which were first triturated in a mortar and sieved through a sieve with a diameter of 0.25 mm. Samples were inserted in 50 cm<sup>3</sup> of 0.01 M CaCl<sub>2</sub> and shaken for 5 hours, then filtered. Total sulfur content was determined nephelometrically, according to the method proposed by Ostrowska et al [12].

Soil pH was determined in H<sub>2</sub>O, at a substrate to water ratio of 1:2.5. The measurements were performed by potentiometry method using a SEN 81st TIX electrode.

The content of organic matter in soil was determined by gravimetric method of weight loss during the annealing of the soil sample in a muffle furnace at 550°C [12].

Activity of soil enzymes were carried out in accordance with the methodology proposed by Schinner et al [13]. The activity of acid and alkaline phosphatase was tested by the colorimetric method, where the activity is measured in µg of p-nitrophenol per 1 g fresh weight soil. Dehydrogenase activity was determined by colorimetric method, using the ability of this enzyme to transfer electrons to a synthetic acceptor, *triphenyltetrazolium chloride* (TTC) which in the oxidized form is almost colorless, but in the reduced form gives colored compound *triphenylformazan* (TPF). The activity was measured in µg of TPF on 1 g fresh weight soil. Urease activity was tested by colorimetric assay based on ammonia formed after the enzymatic hydrolysis of urea, activity is expressed in µg of N per 1 g fresh weight soil.

### *Statistical analysis*

The results of soil chemical data and enzymes activities were tested for normal distribution (Shapiro-Wilk test) prior to statistical analysis. Statistical comparisons of the six sites were made using Tukey test. Correlation was calculated by Pearson's correlation coefficient.

### **Results and discussion**

On all the examined surfaces there was an accumulation of heavy metals and sulfur in the outermost layer of the soil, which gives evidence to the anthropogenic origin of these

elements. The similarity in relation to the number of tested parameters showed Szyndzielnia and Blatnia to be the most correspondent, especially when it comes to metal and sulfur content which were also the highest for those two locations. Higher concentrations of sulfur and heavy metals were linked to the north-west winds that bring pollution from above Bielsko-Biala. Similarity was equally often disclosed by Soszow and Stozek because of their close positions.

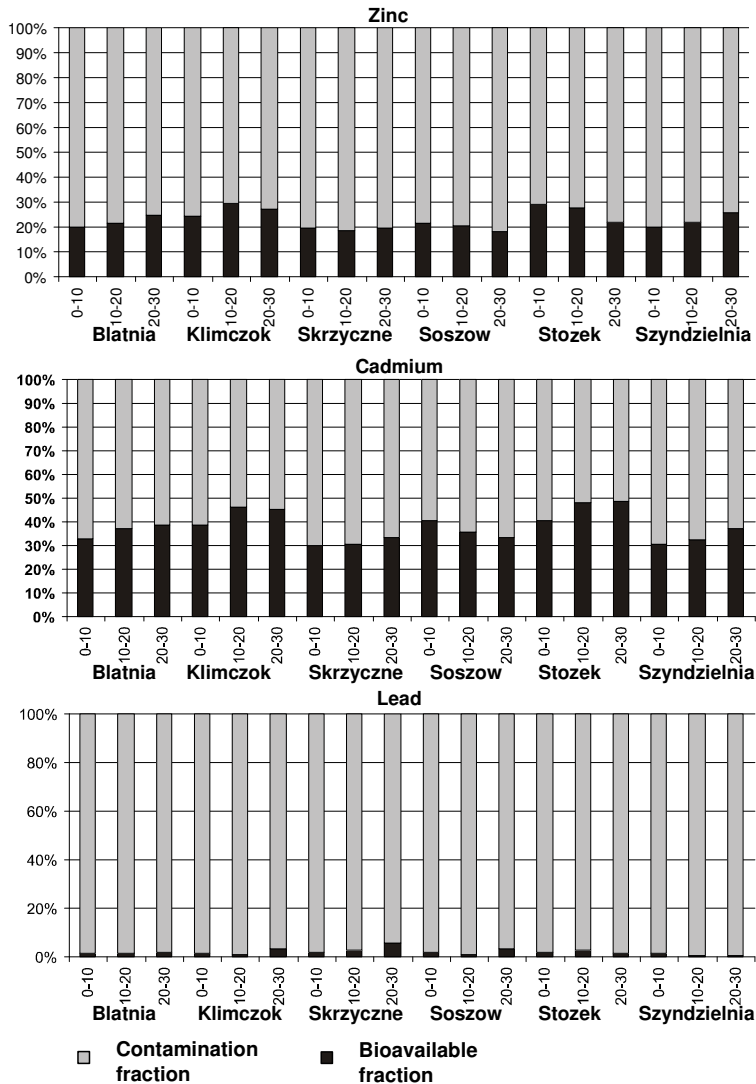

Fig. 1. Percentage of heavy metals (Zn, Cd, Pb) bioavailable fraction in contaminated fraction

Heavy metals and sulfur accumulated in soils, not only modify their properties, but also severely affect the soil microorganisms and change the soil enzymatic activity. Processes such as nitrification and the pace of the organic matter decomposition undergo distinct inhibition [14, 15].

Total dehydrogenase activity is an indicator of the redox system and a measure of respiratory activity of microorganisms. Dehydrogenase is active only within living organisms, and after a cell death their degradation follows quickly. Heavy metals have inhibitory effect on dehydrogenase activity [16-18]. Olszowska [17] found a negative correlation between dehydrogenase activity and the content of Zn, Cd and Pb in soils of pine stands located in the vicinity of the impact of lead and zinc smelter. In the investigated soils, dehydrogenase activity was high, and there was a lack of negative correlation between enzyme activity and the content of heavy metals in the bioavailable fraction and in each of the three examined levels.

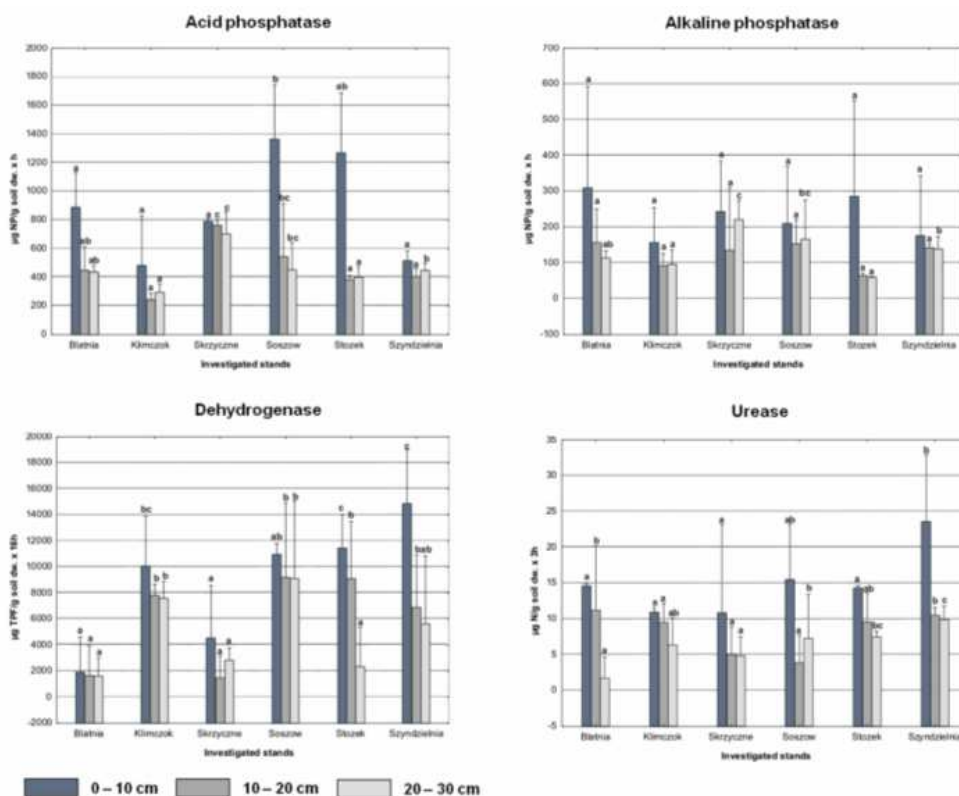

Fig. 2. Activity of investigated soil enzymes.  $p < 0.05$ , ANOVA TUKEY test - homogenous groups marked with the same letters

The activity of urease, which catalyzes the hydrolysis of urea to ammonia and  $\text{CO}_2$ , is related to the pace of change in soil nitrogen. This enzyme is accumulated in the soil in



the form of complexes with organic matter and humus [19]. Nadgorska-Socha et al [20] found urease activity measured by the amount of the produced nitrogen to be around  $75 \mu\text{g N g}^{-1}$  in the soil located under the direct influence of heavy metal emitter. In the investigated soils, the urease activity was expressed as a concentration of secreted nitrogen which was stood at  $6.9 \mu\text{g N g}^{-1}$  on Skrzyczne to  $14.7 \mu\text{g N g}^{-1}$  on Szyndzielnia. A significant decrease in the activity of this enzyme is not related to the concentration of heavy metals, as evidenced by the positive correlation between the content of bioavailable zinc and cadmium and the amount of nitrogen produced in the layer 0-10 cm and lack of correlation in the other layers.

In soils contaminated by heavy metals, a reduction in activity of phosphatases was observed, which was confirmed by studies in the forest soil in the vicinity of the aluminum smelter [4] and soils treated with heavy metals [18]. In the soils from the test site there was a high activity reported as far as the acid phosphatase is concerned; an enzyme that is associated with the amount of bacteria and fungal biomass in soil [21]. The maximum concentration of p-nitrophenol in this case was  $1658.9 \mu\text{g g}^{-1} \text{h}^{-1}$  in soil from Soszow. Besides acid phosphatase among the enzymes that take an active part in the decomposition of organic debris is alkaline phosphatase. In the investigated site concentration of p-nitrophenol in the case of alkaline phosphatase ranged from  $115.3 \mu\text{g g}^{-1} \text{h}^{-1}$  on Klimczok to  $200.4 \mu\text{g g}^{-1} \text{h}^{-1}$  on Skrzyczne. Statistical analysis did not show a negative correlation between the concentration of metals in the bioavailable fraction and the activity of both phosphatases in the 0-10 cm layer, while in the 10-20 cm layer there was a positive correlation observed for cadmium content and the activity of alkaline phosphatase. In addition, in the 20-30 cm layer a positive correlation between the concentration of cadmium and acid phosphatase activity was reported. These results suggest that soil pH for these enzymes are crucial. High activity of acid phosphatase is due to low soils pH while alkaline phosphatase shows greater activity in alkaline soils [5].

The obtained results showed that low concentrations of heavy metals in the soils did not affect the activity of soil enzymes significantly.

The main factors controlling the mobility and availability of heavy metals in soil are pH and organic matter content [22, 23]. Soil pH plays a significant role in the occurrence of soluble and bioavailable forms of zinc and lead. The acidity increase of the soil environment occurs among others due to the deposition of sulfur compounds [24]. At the studied localities the sulfur content was relatively low (from 108.8 to  $176.2 \mu\text{g g}^{-1}$ ). However, statistically significant negative correlation between sulfur content in the soil and soil pH in the surface layers was found, while in the layers 10-20 cm and 20-30 cm the value of the correlation was statistically insignificant. The observed dependencies indicate the influence of precipitation and accumulation of sulfur compounds on pH decrease. The factor which largely determines the enzymatic activity of the soils, is their content of organic matter. Soil organic matter has a large absorptive surface, and many functional groups (carboxyl, thiol and phenolic) that are capable of efficient binding of heavy metals in the form of complexes [25]. The binding of various metals is varied. The strongest relation is between the soil organic matter and Pb. It is also strong for Cd and Zn [26]. In the investigated soils the concentration of lead in bioavailable fraction was minimal, which was indicating strong binding by organic matter. A smaller but still significant was the

degree of binding of cadmium and zinc. The results also show that despite low soil pH, the organic substance contained in the soil is able to bind heavy metals fairly effectively.

Table 1

The correlation coefficient between soil enzymes and bioavailable Zn, Cd and Pb in soil.

Results marked by \* are significant at the  $p = 0.05$  level

	Alkaline phosphatase	Acid phosphatase	Dehydrogenase	Urease
Zn bioavailable	0.08	0.03	-0.13	-0.04
Cd bioavailable	0.65*	0.6*	-0.18	-0.01
Pb bioavailable	0.35	0.27	-0.05	-0.29

## Conclusions

The studies of the soils from the site of Silesian Beskid showed no impact of anthropogenic contaminants (heavy metals and sulfur) on the activity of soil enzymes. High enzyme activity demonstrates the viability of soil microorganisms, proper circulation of biogenic elements such as phosphorus and nitrogen. Therefore, it can be concluded that the causes of Beskid spruce extinction have different backgrounds.

## References

- [1] Kobus J. Zesz Probl Post Nauk Roln. 1995;421a:209-219.
- [2] Tabatabai MA. Soil Sci Soc Amer Madison. 1994;5:775-833.
- [3] Rossel D, Tarradellas J, Bittton G, Morel JL. Use of enzymes in soil ecotoxicology: a case for dehydrogenase and hydrolytic enzymes. In: Tarradellas J, Bitton G, editors. Soil Ecotoxicology. Boca Raton: Lewis Publishers, CRC Press; 1997.
- [4] Kieliszewska-Rokicka B. Soil enzymes and their significance in studies of soil microbiological activity. In: Dahm H, Pokojska-Burdziej A, editors. Microorganisms of the Soil Environment - Physiological, Biochemical, Genetic Aspects. Toruń: Adam Marszałek Publisher; 2001.
- [5] Dick RP. Soil enzyme activities as indicators of soil quality. In: Doran JW, Coleman DF, Bezdieck D, Steward BA, editors. Defining Soil Quality for Sustainable Environment. Madison, WI: Soil Sci Soc Amer Madison; 1994;107-124.
- [6] Hinojosa MB, Carreira JA, Garcia-Ruiz R., Dick R. Soil Biol Biochem. 2004;36:1559-1568. DOI: 10.1016/j.soilbio.2004.07.003.
- [7] Khan S, Cao Q, Hesham AEL, Xia Y, He J. J Environ Sci. 2007;19:834-840. DOI: 10.1016/S1001-0742(07)60139-9.
- [8] Doelman P, Haanstra L. Biol Fertil Soils. 1986;2:213-218.
- [9] Effron D, de la Horra AM, Defrieri RL, Fontanive V, Palma PM. Comm Soil Sci Plant Anal. 2004;35:1309-1321.
- [10] Geiger G, Brandi H, Furner G, Schulin R. Soil Biol Biochem. 1998;30:1537-1544.
- [11] Gupta SK, Vollmer MK, Krebs R. Sci Total Environ. 1996;178:11-20. DOI: 10.1016/0048-9697(95)04792-1.
- [12] Ostrowska A, Gawliński S, Szczubiałka Z. Methods of Analysis and Evaluation of Soil and Plant Properties. Warsaw: Catalog Institute of Environmental Protection; 1991.
- [13] Schinner F, Orhlinger R, Kandeler E, Margensis R. Methods in Biology. Berlin, Heidelberg: Springer Verlag; 1995.
- [14] Frankenberger WT, Dick WA. J Amer Soil Sci Soc. 1983;47:945-951.
- [15] Smith S, Tabatabai MA, Wollum A. Soil Sci Soc Amer. 1999;5:775-833.
- [16] Liang CN, Tabatabai MA. J Environ Qual. 1978;7:291-293.
- [17] Olszowska G. IEP Works, Series A. 1997;834:107-130.
- [18] Kucharski J, Hłasko A, Wyszowska J. Zesz Probl Post Nauk Roln. 2001;476:173-180.
- [19] Burns RG. Soil Enzymes. New York: Academic Press; 1978.
- [20] Nadgórska-Socha A, Łukasik I, Ciepiał R, Pomierny S. Acta Agrophysica. 2006;8(3):713-725.
- [21] Kuperman RG, Carreiro MM. Soil Biol Biochem. 1997;29:179-190.

- [22] Wiśniowska-Kielian B. Zesz Probl Post Nauk Roln. 2000;472:679-688.
- [23] Peralta-Videa JR, Gardea-Torresdey JL, Gomez E, Tiemann KJ, Parsons JG, Carrillo G. Environ Pollut. 2002;119:291-301. DOI: 10.1016/S0269-7491(02)00105-7.
- [24] Motowicka-Terelak T, Terelak H. Zesz Probl Post Nauk Roln. 2000;472:517-525.
- [25] Strawn D, Sparks DL. Soil Sci Soc Am J. 2000;64:144-156.
- [26] Barona A, Aranguiz I, Elias A. Environ Pollut. 2001;113:79-85. DOI: 10.1007/978-1-59745-098-0\_22.

## OCENA AKTYWNOŚCI ENZYMÓW GLEBOWYCH JAKO WSKAŹNIKA WPŁYWU ZANIECZYSZCZEŃ ANTROPOGENNYCH NA FUNKCJONOWANIE EKOSYSTEMÓW LASÓW ŚWIERKOWYCH BESKIDU ŚLĄSKIEGO

Wydział Biologii i Ochrony Środowiska, Uniwersytet Śląski w Katowicach

**Abstrakt:** Aktywność enzymów glebowych uważana jest za dobry wskaźnik naturalnych i antropogennych zaburzeń w funkcjonowaniu gleby. Metale ciężkie w różnym stopniu mogą hamować działanie enzymów w zależności od takich właściwości gleb, jak: zawartość materiałów ilastych, gliny, materii organicznej czy wartości pH roztworu glebowego. Celem pracy było określenie wpływu właściwości fizykochemicznych i biologicznych gleb na kondycję drzewostanów świerkowych w Beskidzie Śląskim. Próbkę glebowe zbadano pod względem aktywności enzymatycznej (fosfataza kwaśna i zasadowa, dehydrogenaza, ureaza) oraz koncentracji trzech wybranych metali ciężkich (Cd, Pb, Zn) i siarki. Analizy nie wykazały obniżonej aktywności badanych enzymów. Prawdopodobnie, mimo niskich wartości pH gleby, zawarta w niej materia organiczna efektywnie wiąże metale ciężkie, ograniczając ich obieg w środowisku. Można stwierdzić, że stan drzewostanów świerkowych w Beskidzie Śląskim nie ma związku z zanieczyszczeniem gleb na tym terenie.

**Słowa kluczowe:** metale ciężkie, enzymy glebowe, świerk pospolity, Beskid Śląski



Elżbieta BOLIGŁOWA<sup>1</sup>, Katarzyna GLEŃ<sup>1</sup>, Janina GOSPODAREK<sup>1</sup>  
and Andrzej SKOCZOWSKI<sup>2</sup>

## EVALUATION OF CHEMICAL PROTECTION EFFECT ON HEALTHINESS OF BROAD BEAN LEAVES AND ELEMENTS OF YIELDING

### OCENA ODDZIAŁYWANIA CHEMICZNEJ OCHRONY NA ZDROWOTNOŚĆ LIŚCI I ELEMENTY PŁONOWANIA BOBU

**Abstract:** The paper aimed at an evaluation of chemical protection means (Vitavax 200FS, Decis 2.5 EC, Fastac 100EC and Penncozeb 80 WP) effect on leaf healthiness of two broad bean cultivars (White Windsor and White Hangdown), and the elements of seed yield structure. Obtained results demonstrated that years significantly diversified intensity of fungal diseases on broad bean leaves and the elements of seed yield structure. Excessive moisture during vegetation period favours leaf infection by brown spot (*B. fabae*) and worsens the elements of seed yield structure. Broad bean leaves susceptibility to fungal diseases and seed structure elements depend on the cultivar. White Windsor cultivar, intended for early harvest is characterized by markedly greater sensitivity to fungal diseases and produces more seeds per pod with higher 1000 grain weight. Foliar application of chemical protection means, conducted three or four times (2 x insecticide + 1 x fungicide or 3 x insecticide + 1 x fungicide) guarantees better health state of plants and favours increase in 1000 grain weight.

**Keywords:** broad bean, pesticides, leaf diseases, elements seed yielding

### Introduction

In some regions of Poland (in Zulawy Wislane, Lubelskie and Mazowieckie Provinces and in the south) broad bean is cultivated as a vegetable plant [1]. In recent years the interest in this plant has been growing due to its taste values, high protein content in the seeds and other nutrients [2]. During vegetation period, broad bean as a legume and field bean are attacked by the same agrophages which cause losses in yield and worsen seed quality. According to Robak and Szejda [3], Dłużniewska et al [4] *Botrytis fabae* and *Ascochyta fabae* are the diseases most frequently occurring on field bean leaves during vegetation period. These diseases may to the greatest extent contribute to losses in yield. Legume plant healthiness during vegetation period depends on many factors: weather conditions, applied agrotechnical measures (among others: crop rotation, cultivar or protection) [5-7]. Appropriate agrotechnical measures, including chemical protection, should be applied to prevent the occurrence of legume plant diseases [5, 8]. Therefore, chemical means of broad bean protection have been sought, which would meet the requirements of plant protection against the agrophages, would be highly selective and safe for humans and the environment. In result, chemicals used for broad bean protection would not accumulate in the seeds. There is a lack of reports on these problems.

<sup>1</sup> Department of Agricultural Environment Protection, University of Agriculture in Krakow, al. A. Mickiewicza 21, 31-120 Kraków, email: rrboligl@cyf-kr.edu.pl

<sup>2</sup> Institute of Plant Physiology, Polish Academy of Sciences, ul. Niezapominajek 21, 30-239 Kraków, email: skoczowski@ifr-pan.krakow.pl

The paper evaluated the effect of plant chemical protection means (Vitavax 200FS, Decis 2.5 EC, Fastac 100 EC, Penncozeb 80WP) on leaf healthiness of two broad bean cultivars (White Windsor and White Hangdown) and the elements of seed yield structure.

## Materials and methods

Field experiments were conducted in 2010-2011 at Agricultural Experimental Farm of the University of Agriculture in Krakow situated in Prusy. Two factor experiment was carried out using randomised sub-block method in three replications on the soil of very good wheat complex. The first experimental factor were broad bean cultivars (White Windsor and White Hangdown) and the second their chemical protection (control, seed dressing with Vitavax 200FS, Decis 2.5 EC, Fastac 100EC and Penncozeb 80WP preparations). Prior to sowing broad bean seeds, except the control object, were dressed with 4 cm<sup>3</sup>/1 kg of seeds dose of Vitavax preparation. The seeds were sown in the first decade of April to the depth of 6 cm with row spacing 50 cm and 10 seeds per row. Soil tillage and fertilization were conducted in compliance with agrotechnical requirements for this plant species. During vegetation period broad bean was protected against weeds by mechanical methods. Diseases and pests were controlled by means of the following combinations of chemical protection:

K1 - control (without protection)

K2 - seed dressing against diseases with Vitavax 200FS preparation,

K3 - seed dressing against diseases with Vitavax 200FS preparation + Decis 2.5 (insecticide) EC + Fastac 100EC (insecticide) + Penncozeb 80W (fungicide),

K4 - seed dressing against diseases with Vitavax 200FS + 2 x Decis 2.5 EC (insecticide) + Fastac 100EC (insecticide) + Penncozeb 80 WP (fungicide).

Decis 2.5EC preparation dosed 0.25 dm<sup>3</sup>/ha was applied foliarly to control aphids. The first plant protection measure with this chemical means was conducted at the moment of aphid appearance. In the fourth combination this preparation was applied repeatedly after 7 days. On the other hand, Fastac 100EC dosed 0.09 dm<sup>3</sup>/ha was used against *Bruchus rufimanus* during the flowering cessation of the first level of broad bean inflorescence. On the other hand, Penncozeb 80WP preparation dosed 2 kg/ha against fungal diseases was applied before plant flowering.

At the development stage of broad bean BBCH (70-79) leaf health state was evaluated on 25 leaves randomly selected from a plot. Occurrence of individual fungal diseases on leaves was assessed on a 5-degree scale (1-5) showing increasing plant infection. The broad bean yielding components were also assessed: 1000 grain weight, number of pods per plant and number of seeds per pod. Results referring to the intensity of fungal diseases on plant leaves were presented as infection index. Subsequently, all results were subjected to the analysis of variance and the significance of mean differences was verified by means of Tukey's test  $\alpha = 0.05$ .

## Results and discussion

During vegetation period broad bean leaves were attacked mainly by brown spot disease (*B. fabae*) and ascochytirosis (*A. fabae*). Occurrence of these fungal diseases on the same plant species, *ie* field bean was confirmed also by other authors [4, 7, 8].

A considerable diversification of the weather conditions was observed from April to July in the investigated years 2010-2011, which influenced the state of plant health. An excess of rainfall was registered in May (294.60 mm) and June (155.50 mm) 2010, both in comparison with multiannual period (respectively for these months 65.26-80.04 mm) and the year 2011 (60.70-44.40 mm). Also, the beginning and end of broad bean vegetation in 2011 were characterized by the excess of moisture (April - 77.90 mm, July - 194.40 mm). Considering the period of observations, July 2010 may be regarded as warmer (air temperature 20.50°C) and drier (rainfall 92.70 mm), whereas in 2011 July was a wet month (rainfall 194.40 mm) and cooler (air temperature 17.57°C). Generally the year 2010 featured heavy rainfalls (rainfall total from April to July reaching 582.30 mm) in comparison with 2011 (rainfall total for the same period was 377.40 mm). Mean air temperature from April to July was on a similar level in both years. In the opinion of Podlesny [5, 6] and Majchrzak and Kurowski [4] field bean and other legumes are greatly sensitive both to the excess and deficit of moisture during vegetation period. Such conditions favour increased intensity of fungal diseases and contribute to losses in seed yield. In the Authors' own investigations, irrespective of applied plant protection, years had a significant influence on the index of leaf infection by *B. fabae* (brown spot) and *A. fabae* (ascochytois), and on elements of yield structure. An assessment of broad bean healthiness conducted in 2011 at the beginning of the second decade of July (which was a very wet month) revealed a notable increase in ascochytois (*A. fabae*) on leaves (Table 1). Also a significant increase in 1000 grain weight and the number of seeds formed per pod were registered in the analysed year. On the other hand, the weather conditions in 2010 favoured a marked increase in brown spot disease on leaves (*B. fabae*) and contributed to a decrease in the number of seeds per pod and 1000 grain weight. However, irrespective of the years, mean leaf infection index by *B. fabae* and *A. fabae* was high.

Table 1  
Mean infection index of broad bean leaves by fungal pathogens and elements of yielding in 2010-1011

Specification	Years		LSD <sub>0.05</sub>
	2010	2011	
Leaf fungal diseases:			
brown spot ( <i>B. fabae</i> )	45.78	34.25	4.31
ascochytois ( <i>A. fabae</i> )	35.39	47.00	6.26
Elements of yielding:			
1000 grain weight [g]	1058.99	3311.25	297.35
number of pods per plant [pcs.]	8.48	9.69	n.s.
number of seeds per pod [pcs.]	2.53	3.39	0.743

n.s. - non-significant difference

In Authors' own research it was found that intensification of fungal diseases on broad bean leaves and seed yield structure depended also on the cultivar (Table 2). In comparison with White Hangdown (industrial variety), White Windsor variety intended for direct consumption revealed a greater sensitivity to fungal infections. Leaves of this variety revealed a significantly higher mean infection index by the above-mentioned pathogenic fungi. Seeds of White Windsor cultivar were characterized by a higher 1000 grain weight

and pods produced more seeds. On the other hand, White Hangdown variety set more pods but with a lesser number of seeds and lower 1000 grain weight.

Table 2  
Mean infection index of broad bean cultivars leaves by fungal pathogens and elements of yielding (irrespective of years)

Specification	Cultivars		LSD <sub>0.05</sub>
	White Windsor	White Hangdown	
Leaf fungal diseases			
brown spot ( <i>B. fabae</i> )	42.53	37.50	4.32
ascochytois ( <i>A. fabae</i> )	42.81	39.58	2.36
Yielding elements			
1000 grain weight [g]	2352.88	2017.36	296.52
number of pods per plant [pcs.]	8.77	10.40	1.51
number of seeds per pod [pcs.]	3.24	2.69	0.16

The programme of chemical protection applied in the Authors' own investigations significantly diversified intensification of brown spot disease (*B. fabae*) and ascochytois (*A. fabae*) on broad bean leaves (Table 3). Irrespective of the cultivar, full chemical plant protection (K4) composed of 4 measures, *ie* seed dressing with Vitavax 200 FS preparation and two times foliar application of Decis 2.5 EC + single application of Fastac 100 EC and Penncozeb 80 WP preparations prior to seed sowing, produced the best results of leaves protection against these diseases. Similarly, Dłużniewska et al [4] and Podlesny [5] point out that full chemical protection best guards plants against fungal diseases. Obtained results of the Authors' own investigations reveal also that limiting the activities to only one measure, *ie* seed dressing with Vitavax 200 FS (K2) preparation before sowing, does not guard the plant against infection by *B. fabae* and *A. fabae* fungi. Seed dressing limits disease development in the initial period of plant vegetation. Also Lenartowicz [9], Martyniuk [10] and Glen et al [11] addressed this issue.

Table 3  
Effect of chemical protection on mean infection index of broad bean leaves by *B. fabae* (brown spot) and *A. fabae* (ascochytois) and elements of yieldings

Chemical plant protection - combination	Leaf infection index by		Elements of yielding		
	<i>B. fabae</i> (brown spot)	<i>A. fabae</i> (ascochytois)	1000 grain weight [g]	number of pods [pcs./plant]	number of seeds per pod [pcs.]
K1	38.61	43.17	2007.37	9.33	2.76
K2	45.56	46.83	2055.55	9.70	3.14
K3	40.22	37.00	2366.11	9.89	2.95
K4	35.67	37.78	2311.46	9.43	2.99
LSD <sub>0.05</sub>	8.13	4.51	343.96	n. s.	n. s.

K1-K4 as in methodology; n.s.- not significant difference

Considering yield structure elements, the yielding is determined by 1000 grain weight. Applied K3 and K4 combinations of chemical protection, *ie* foliar application of chemicals (K3 - 2 x insecticide + 1 x fungicide or K4 - 3 x insecticide + 1 x fungicide) carried out three or four times contributed to a significant increase in this feature by respectively 17.87 and 15.15% in comparison with the control. Results of Authors' own investigations



are approximate to reports of Kulig et al [8]. On the other hand, applied chemical protection did not diversify the other elements of yield structure. The results were not confirmed by research conducted by Kulig et al [8], who demonstrated that intensive chemical protection of field bean contributes to increase in the number of seeds per pod and the number of pods.

### Conclusions

1. Years significantly diversify intensity of fungal diseases on broad bean leaves and elements of seed yield structure.
2. Excess of moisture during vegetation period favours increased leaf infection by brown spot (*B. fabae*) and worsens elements of seed yield structure.
3. Broad bean leaves susceptibility to fungal diseases and seed yield structure elements depend on the cultivar. White Windsor broad bean cultivar intended for early harvest is characterized by a significantly higher susceptibility to fungal diseases and produces more seeds per pod with a higher 1000 grain weight.
4. Foliar application of chemical means of plant protection (2 x insecticide + 1 x fungicide or 3 x insecticide+ 1 x fungicide) carried out three or four times ensures a better health state of plants and favours increase in 1000 broad bean grain weight.

### Acknowledgement

Scientific publication financed from the funds for science in 2010-2012 as a research project (NN310038438).

### References

- [1] Łabuda H. Economic importance of *Vicia faba* L. cultivated in Poland and worldwide. Zesz Prob Post Nauk Roln. 1997;446:55-59.
- [2] Mnichowska H, Pędziński M. Broad bean. Fruit and Vegetables. 2002;6:28.
- [3] Robak J, Szejda J. The most dangerous diseases and pests. Legumes. Hortpress. 2008;19-29.
- [4] Dłużniewska J, Nadolnik M, Kulig B. Effect of chemical protection on the health state of low-tannin field bean cultivars (*Vicia faba* L.). Progr Plant Protec./ Post Ochr Roślin. 2007;4(2):81-84.
- [5] Podleśny J. Improvement of selected elements of legume production technology. Studia i raporty IUNG-PIB Puławy. 2007;9:207-238.
- [6] Podleśny J. Effect of the amount and distribution of rainfall on growth, development and yielding of self-terminating and traditional field bean cultivars. Acta Agrophys. 2009;14(2):413-423.
- [7] Majchrzak B, Kurowski TP. Reaction of field bean to pathogenic fungi under different agricultural conditions. Phytopath. Polon. 2000;20:67-76.
- [8] Kulig B, Ropek D, Dłużniewska J. Economic and production effectiveness of plant protection measures in cultivation of morphologically diversified field bean cultivars. Pamiet Puław. 2006;142:251-261.
- [9] Lenartowicz W. Effect of selected seed dressings on limiting diseases and pests, development and yielding of field bean. Mat 35 Ses Nauk Inst Ochr Roślin. 1995;2:308-310.
- [10] Martyniuk M, Oroń J, Woźniakowska A, Martyniuk S. Effect of chemical dressings on survivability of nodule bacteria on field bean seeds and on symbiosis process. Pamiet Puław. 2000;121:41-42.
- [11] Gień K, Boligłowa E, Gospodarek J. Effect of seed dressings on healthiness of broad bean seeds. Progr Plant Protec./ Post Ochr Roślin. 2011;51(4):1628-1632.

## OCENA ODDZIAŁYWANIA CHEMICZNEJ OCHRONY NA ZDROWOTNOŚĆ LIŚCI I ELEMENTY PLONOWANIA BOBU

<sup>1</sup> Katedra Ochrony Środowiska Rolniczego, Uniwersytet Rolniczy w Krakowie

<sup>2</sup> Instytut Fizjologii Roślin PAN w Krakowie

**Abstrakt:** Celem pracy była ocena wpływu środków chemicznej ochrony (Vitavax 200 FS, Decis 2,5 EC, Fstac 100 EC, Penncozeb 80 WP) na zdrowotność liści dwóch odmian bobu (Windsor Biały i Hangdown Biały) oraz elementy struktury plonu nasion. Uzyskane wyniki wykazały, że lata istotnie różnicują nasilenie chorób grzybowych na liściach bobu oraz elementy struktury plonu nasion. Nadmiar wilgoci w okresie wegetacji sprzyja wzrostowi porażenia liści przez czekoladową plamistość (*B. fabae*) i pogarsza elementy struktury plonu nasion. Podatność liści bobu na choroby grzybowe oraz elementy struktury plonu nasion zależą od odmiany. Odmiana bobu Windsor Biały przeznaczona na wczesny zbiór cechuje się istotnie większą wrażliwością na choroby grzybowe i wytwarza więcej nasion w strąku o większej masie 1000 nasion. Trzykrotna lub czterokrotna aplikacja nalistna środków chemicznej ochrony (2x insektycyd + 1x fungicyd lub 3 x insektycyd + 1x fungicyd) zapewnia lepszy stan zdrowotny roślin i sprzyja wzrostowi masy 1000 nasion bobu.

**Słowa kluczowe:** bób, pestycydy, choroby liści, elementy plonowania nasion

Tomasz CIESIELCZUK<sup>1</sup>, Czesława ROSIK-DULEWSKA<sup>2</sup> and Jacek LENARTOWICZ<sup>3</sup>

## INVESTIGATIONS OF COMPOSTS AS A POTENTIAL SORBENTS OF ALIPHATIC HYDROCARBONS

### BADANIA KOMPOSTÓW JAKO POTENCJALNYCH SORBENTÓW WĘGLOWODORÓW ALIFATYCZNYCH

**Abstract:** Products from crude oil processing are widely used in industry and are used as lubricants and fuels in motor vehicles. Due to the pipeline failure, lost of substances on the loading stations area and traffic crashes, petroleum products moves to different components of environment. The high costs of removal of oil spills to the soil and ground, forces to search for low-cost and effective methods which can reduce spread of these substances. There are professional sorbents on the market for quick and effective removal petroleum products from ground or water surfaces. The aim of this work was test of two composts and two commercial sorbents. Tests were carried with aliphatic hydrocarbons (heptane, octane and decane) by capillary rise method. Best results were obtained for organic commercial sorbent, worst results were noted for composts with natural humidity and mineral sorbent - mostly used in rescue practices. Obtained results show the real possibility of use composts as cheap petroleum derivatives sorbents.

**Keywords:** compost, sorption, sorbents, aliphatic hydrocarbons

#### Introduction

Crude oil products are widely used in industry, and are used as lubricants and fuels in motor vehicles. Due to the pipeline failure, the movement of these substances on the loading stations and traffic crash land, oil products penetrate the various components of the environment. The high costs of liquidation of consequences of oil spills to the soil and ground forces to search for low-cost and effective methods of limiting the spread of these substances. In common use there are sorbents so that a fast way to remove organic liquids from the surface of the land or water [1-3]. In case of organics removal from air stream, organic wastes could be used [4]. In case of manufactured sorbents a lot of primary energy and new raw materials are use - so this is usually much more expensive and environmentally and ethic discussible [5-7]. Using compost derived from municipal waste as a sorbent has numerous advantages: compost is a product that is almost spontaneously created from mixed municipal waste, or can be made from separated biodegradable fraction of municipal waste. Compost is biologically active, and acts to support the natural processes of decomposition organic compounds after use as sorbent. In this study two types of municipal waste composts and two commercial sorbents in order to determine their suitability for the sorption of hydrocarbon chain were tested.

<sup>1</sup> Department of Land Protection, University of Opole, ul. Oleska 22, 45-052 Opole, phone 77 401 60 20, email: tciesielczuk@uni.opole.pl

<sup>2</sup> Institute of Environmental Engineering of the Polish Academy of Sciences, ul. M. Skłodowskiej-Curie 34, 41-819 Zabrze, phone 32 271 64 81, email: dulewska@ipis.zabrze.pl

<sup>3</sup> Msc. at Department of Land Protection, University of Opole, ul. Oleska 22, 45-052 Opole, phone 77 401 60 20

## Material and methods

In this work the wettability of compost from municipal waste and commercial sorbents was tested. Compost K - made of mixed municipal waste, compost Z - made of biodegradable fraction of municipal waste. Commercial organic sorbent (PS) and mineral (ED) have been used as reference sample. Wettability by aliphatic hydrocarbons with chain length C7, C8 and C10, using capillary lift method was tested. Absorbents in an amount of 20 g (8 g in case of PS) filled up to a glass cylinder, and were immersed in the test vessel with the organic liquid. The mass readings started during the start of immersion. Mass of organic liquid in the vessel using the PW-WIN computer program was recorded. The measuring time was 300 s. In this study it was determined the total amount of absorbed fluid and the height of liquid lift. All tested organic liquids were tested separately each on new portion of particular sorbents in duplicates.

## Results and discussion

Investigated composts had different chemical composition. One of the most important parameter is organic matter content in tested samples (Table 1). The highest organic matter content has PS sorbent made from peat - over 98.7%. The lowest observed value - according to expected ED sorbent - under 1%. Investigated composts: K and Z had respectively 48.16 and 33.4% of organics, is typical values for these materials made of biodegradable wastes.

Table 1

Characteristic of sorbents used in experiments

Parameter	ED	PS	K	Z
Organic [%]	0.87±0.01	98.73±0.13	48.16±4.18	33.4±1.38
TOC [% d.m.]	<0.5	95.7±0.28	24.9±4.1	21.4±6.2
pH in H <sub>2</sub> O	6.16±0.03	3.85±0.02	7.95±0.06	7.85±0.01
EC [mS/cm]	0.709±0.11	0.09±0.01	3.02±0.38	1.14±0.08
Gravity [g/dm <sup>3</sup> ]	421.8±6.1	93.7±3.7	185.2±9.6	196.4±7.3

Table 2

Granulometric composition of investigated sorbents

Grain size [mm]	ED	PS	K	Z
> 4	0.0	0.4	34.8	27.4
> 2	43.6	15.0	12.5	11.8
> 1	54.7	10.6	20.0	18.6
> 0.5	1.70	17.2	13.9	11.9
> 0.25	0.07	22.7	16.9	19.7
> 0.1	0.01	20.0	5.2	8.2
< 0.1	0.01	9.16	1.5	2.4

Also granulometric composition of tested sorbents (Table 2) was different. Especially high content of fine fraction (< 0.1 mm) was found in organic sorbent PS. Also compost K has characteristic composition with almost 35% content over 4 mm. Granulometric composition suggest that sorbent PS with the fine particles could have the best sorption

properties, however composts K and Z with high organic matter content also could be suitable for organic liquids sorption.

Table 3

Capillary rise of aliphatic hydrocarbons for tested materials [m]

	ED	PS	K	Z
C7	0.020	0.070	0.038	0.047
C8	0.020	0.070	0.045	0.046
C10	0.020	0.066	0.035	0.050

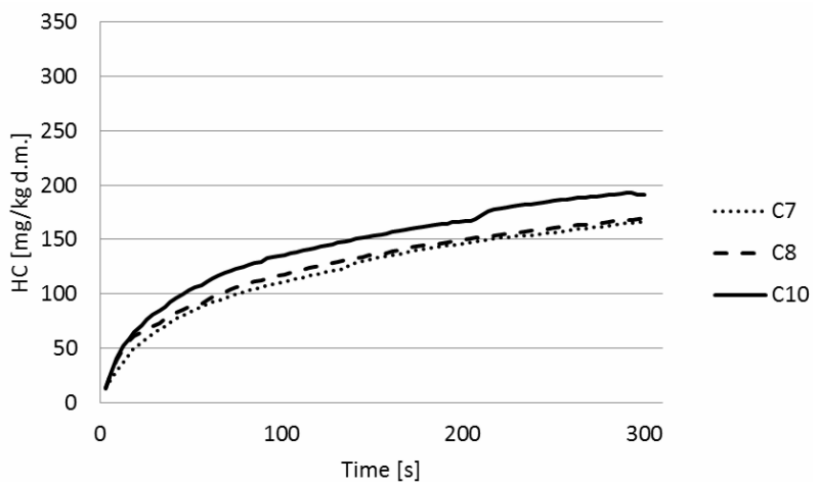

Fig. 1. Capillary rise of aliphatic HC on sorbent EC

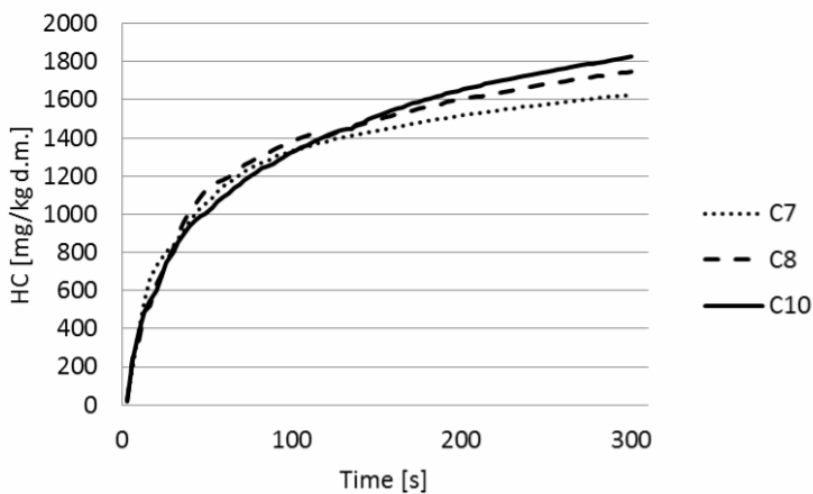

Fig. 2. Capillary rise of aliphatic HC on sorbent PS

The capillary rise of investigated hydrocarbons was different in all tested materials (Table 3). The lowest height was reached by ED commercial sorbent - 0.02 m for all organic liquids. In case of PS sorbent 0.07 m for C7 and C8 and close value for C10. Intermediate values were noted for both tested composts - from 0.035 to 0.05 m confirm good wettability of dry materials. Dynamics of capillary rise of investigated liquids was different for PS and similar for rest tested materials (Figs. 1-4). The worst results - over 125 g/kg d.m. were obtained for decane on compost K material the best - over 1825 g/kg d.m. also for decane on PS sorbent and much better than data obtained for these sorbents used for sorption of n-alkanes from water solution [8].

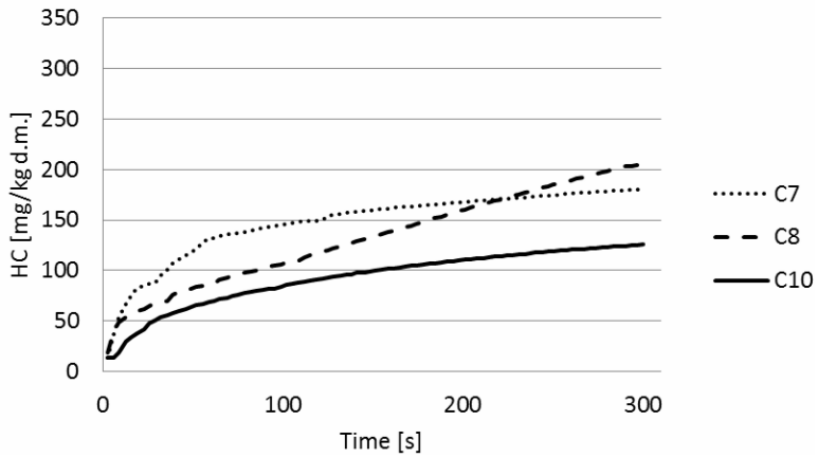

Fig. 3. Capillary rise of aliphatic HC on compost K

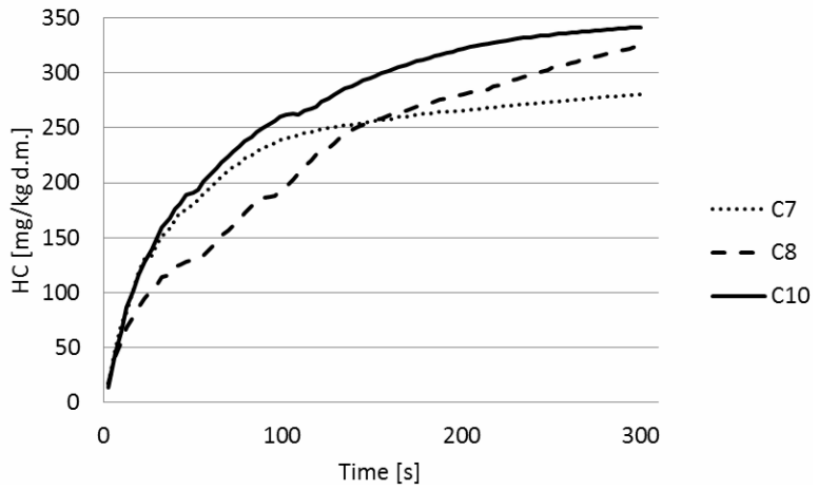

Fig. 4. Capillary rise of aliphatic HC on compost Z

Best sorption results (over 5 times better sorption capacity than tested compost) obtained for organic sorbent show only raw data. But from environmental point of view it is better to use compost made from municipal wastes than this sorbent made from peat. Moreover organic commercial sorbent is about 100 times more expensive than tested composts.

### Conclusion

All tested materials were sorbet organic liquids. The best results were obtained for a commercial hydrocarbons sorbent material PS. This was the result of a significant proportion of fine particles and significant organic matter content. Obtained results for compost Z also were good. The best results (more than 340 g/kg d.m.) were obtained in case of this material for decane. Poorer results were obtained for compost K, which, despite considerable content of organic matter sorbet only 205 g/kg d.m. The worst results were obtained for the ED mineral sorbent (190 g/kg d.m. and only 0.02 m of HC liquid rise) as a result of the grain size composition of the tested material. Tested composts can be a cheap and environmentally friendly alternative to commercial hydrocarbons sorbents.

### Acknowledgments

Investigations were supported by national grant No. N N523 565038

### References

- [1] Chen H, Chen S, Quan X, Zhao H, Zhang Y. Sorption of polar and nonpolar organic contaminants by oil-contaminated soil. *Chemosphere*. 2008;73:1832-1837
- [2] Möller A, Guimaraes AP, Gläser R, Staudt R. Uptake-curves for the determination of diffusion coefficients and sorption equilibria for *n*-alkanes on zeolites. *Microporous and Mesoporous Mater*. 2009;125:23-29.
- [3] Oyanedel-Crever VA, Fuller M, Smith JA. Simultaneous sorption of benzene and heavy metals onto two organoclays. *J Colloid and Interface Sci*. 2007;309:485-492
- [4] Mathur AK, Majumder CB, Chatterjee S. Combined removal of BTEX in air stream by using mixture of sugar cane bagasse, compost and GAC as biofilter media. *J of Hazard Mater*. 2007;148:64-74.
- [5] Koh SM, Dixon JB. Preparation and application of organo-minerals as sorbent of phenol, benzene and toluene. *Appl Clay Sci*. 2001;18:111-122.
- [6] Trung TK, Ramsahye NA, Trens P, Tanchoux N, Serre C, Fajula F, Férey G. Adsorption of C5-C9 hydrocarbons in microporous MOFs MIL-100(Cr) and MIL-101(Cr): A manometric study. *Microporous and Mesoporous Mater*. 2010;134:134-140.
- [7] Wefer-Roehl A, Graber ER, Borisover MD, Adar E, Nativ R, Ronen Z. Sorption of organic contaminants in a fractured chalk formation. *Chemosphere*. 2001;44:1121-1130.
- [8] Ciesielczuk T, Karwaczyńska U, Rosik-Dulewska C. Możliwości zastosowania kompostu z odpadów do usuwania węglowodorów alifatycznych C6-C9 z roztworu. *Rocz Ochr Środ*. 2011;13:1301-1314.

## **BADANIA KOMPOSTÓW JAKO POTENCJALNYCH SORBENTÓW WĘGLOWODORÓW ALIFATYCZNYCH**

<sup>1</sup> Samodzielna Katedra Ochrony Powierzchni Ziemi, Uniwersytet Opolski

<sup>2</sup> Instytut Podstaw Inżynierii Środowiska PAN, Zabrze

**Abstrakt:** Produkty przeróbki ropy naftowej znajdują szerokie zastosowanie w przemyśle, a także są wykorzystywane jako środki smarne i pędne w pojazdach mechanicznych. Z uwagi na rozszczelnienia sieci przesyłowych, obrót tymi substancjami na stacjach przeładunkowych, a także katastrofy w ruchu lądowym produkty ropopochodne przenikają do różnych komponentów środowiska. Wysokie koszty likwidacji skutków wycieków ropopochodnych do gleb i gruntu zmuszają do poszukiwania tanich i efektywnych metod ograniczających rozprzestrzenianie się tych substancji. W powszechnym użyciu znajdują się sorbenty, dzięki którym w szybki sposób można usuwać ciecze organiczne z powierzchni ładu czy wody. W pracy testowano sorbenty i komposty z odpadów w celu określenia ich przydatności do sorpcji węglowodorów łańcuchowych. Zastosowano dwa rodzaje kompostów oraz dwa sorbenty komercyjne. Badano zwilżalność testowanych materiałów węglowodorami alifatycznymi o długości łańcucha C7, C8 i C10 metodą wzniosu kapilarnego. Najlepsze rezultaty osiągnięto dla organicznego sorbentu komercyjnego, najgorsze zaś dla kompostów o naturalnej wilgotności oraz komercyjnego sorbentu mineralnego. Uzyskane wyniki wskazują na możliwość zastosowania kompostów jako tanich sorbentów substancji ropopochodnych.

**Słowa kluczowe:** komposty, sorpcja, sorbenty, węglowodory alifatyczne



Marcin DEBOWSKI<sup>1</sup>, Magda DUDEK<sup>1</sup>, Marcin ZIELIŃSKI<sup>1</sup> and Anna GRALA<sup>1</sup>

## TECHNOLOGICAL EFFECTIVENESS OF METHANE FERMENTATION OF PRAIRIE CORDGRASS (*Spartina pectinata*)

### EFEKTYWNOŚĆ TECHNOLOGICZNA PROCESU FERMENTACJI METANOWEJ SPARTINY PRERIOWEJ (*Spartina pectinata*)

**Abstract:** This study was aimed at identifying the feasibility of using prairie cordgrass (*Spartina pectinata*) in processes of methane fermentation. Effectiveness of the anaerobic process including the quantity and composition of biogas produced and reaction kinetics was determined based on respirometric measurements. Fermentation was run under mesophilic conditions at the initial tank loading with a feedstock of organic compounds ranging from 0.5 to 1.5 g o.d.m./dm<sup>3</sup> · d. Experiments were divided into two stages, with plant part being the criterion of division. At stage I, model fermentation tanks were fed the assumed quantities of pre-treated aerial part (roof), whereas at stage II - with the underground part (root) of prairie cordgrass. Before the exact process of anaerobic decomposition, the substrate was subject to mechanical disintegration in a ball grinder. For comparative purposes, maize silage (*Zea mays*) - being the main plant substrate used in agricultural biogas works, was subject to methane fermentation under the same conditions (stage III). The study demonstrated that the effectiveness of the methane fermentation process was directed influenced by the type of substrate tasted. The highest technological effects including biogas production and its qualitative composition were noted in the case of maize silage and the aerial part of prairie cordgrass. Significantly lower effectiveness of production of gaseous metabolites of anaerobes was determined at the stage when the exploited fermentation tanks were fed with biomass of the underground part of test plant. The course and final outcomes of the fermentation process were also directly affected by the applied loading of fermentation tanks with a feedstock of organic matter.

**Keywords:** *Spartina pectinata*, anaerobic process, biogas, methane fermentation, renewable energy

### Introduction

Stimulation of the advance in renewable energy systems involves the development and implementation of economically-justified technological solutions. Examples, applied in the technical scale, are agricultural biogas works that enable organic substrates transformation into biogas. Exploitation of technological systems of this type is, principally, based on plant substrates, maize silage in particular [1, 2]. Contemporarily, the use of maize silage in the process of biogas production is cost-ineffective and, additionally, arouses great controversies linked with increased prices of plant products used for food purposes [3].

A high primary production and a significant energetic potential are typical traits of *Spartina spp.*, occurring mainly in the USA, Canada and China [4, 5]. It overgrows, most of all, coastal and boggy areas where - owing to the root system - it diminishes erosion of coastline and constitutes a natural barrier against surface flows by absorbing contaminants [6]. *Spartina spp.* is applied in practice as feedstuff or as an additive to biofood [7-9].

In Poland, cordgrass is uncommon and so far has not found wider application, except for the use of prairie cordgrass (*Spartina pectinata*) as an ornamental plant. It seems, however, that its high primary biomass production and capability to adapt to extreme

---

<sup>1</sup> Department of Environmental Engineering, Faculty of Environmental Sciences, University of Warmia and Mazury in Olsztyn, ul. Warszawska 117, 10-719 Olsztyn, phone 89 524 56 08, fax 89 524 56 05, email: magda.dudek@uwm.edu.pl

biotopic conditions may elicit an increased interest in its application in the power industry for biofuels production.

The objective of this study was to determine technological effectiveness of the fermentation process of prairie cordgrass (*Spartina pectinata*) and to characterize biogas production kinetics under static conditions.

## Methodology

Experiments aimed at determining the effectiveness of methane fermentation of prairie cordgrass (*Spartina pectinata*) were conducted in model respirometric tanks at a temperature of 35°C, at retention time of 20 days. Anaerobic sludge originating from fermentation tanks of a farm biogas works based on co-fermentation of slurry and maize silage, was used as the inoculum (Table 1).

Table 1

Characteristics of anaerobic sludge used in the experiment

Parameter	Unit	Min. value	Max. value	Mean	Standard deviation
pH	-	7.64	7.95	7.795	0.219
Hydration	[%]	96.45	96.9	96.675	0.318
Dry matter	[%]	3.1	3.55	3.325	0.318
Volatile substances	[% d.m.]	48.23	51.79	50.01	2.517
Ash	[% d.m.]	49.36	53.05	51.205	2.609
CST	[s]	472	481	476.5	6.363

The conducted experiment was divided into three stages. The criterion of division was the type of organic substrate introduced to fermentation tanks: stage I - *Spartina pectinata* (roof), stage II - *Spartina pectinata* (root), and stage III - maize silage. The characteristics of organic substrates were presented in Table 2.

Table 2

Characteristics of plant biomass used in the experiment

Parameter	Unit	Type of plant substrate					
		<i>Spartina pectinata</i> (root)		<i>Spartina pectinata</i> (roof)		Maize silage	
		Mean	SD	Mean	SD	Mean	SD
Total dry matter	[mg/g]	620	4.04	740	4.93	280	5.06
Mineral substances	[mg/g d.m.]	62	3.63	74	2.19	28	2.71
Organic substances	[mg/g d.m.]	558	3.63	666	2.19	252	2.71

Owing to the applied loading of fermentation tanks with a feedstock of organic compounds, each stage was divided into three experimental series: series 1-0.5 g o.d.m./dm<sup>3</sup> · d, series 2-1.0 g o.d.m./dm<sup>3</sup> · d, and series 3-1.5 g o.d.m./dm<sup>3</sup> · d. Before being introduced to model fermentation tanks, the organic substrates used in the experiment were subjected to disintegration in a ball grinder to decrease fraction size and to unify the experimental material. Study design was presented in Table 3.

Table 3

Study design

Type of organic substrate (Stage)	Series	Load [g o.d.m. /dm <sup>3</sup> ·d]	Amount of anaerobic sludge in reaction tanks [cm <sup>3</sup> ]
<i>Spartina pectinata</i> (ground part) (I)	1	0.5	200
	2	1.0	
	3	1.5	
<i>Spartina pectinata</i> (roof) (II)	1	0.5	200
	2	1.0	
	3	1.5	
Corn silage (III)	1	0.5	200
	2	1.0	
	3	1.5	

Respirometric kits used in the study enabled: determination of the activity of the process, evaluation of the susceptibility of the tested substrates to degradation process under anaerobic conditions by microflora of activated sludge, as well as quantitative and qualitative characteristics of metabolites of these microorganisms. Deoxidization of tanks and anaerobic conditions were achieved by blowing the tanks through with nitrogen after substrate feeding. A complete measuring system consisted of: reaction tank and measuring-recording unit that was analyzing the value of partial pressure generated in the tank as a result of plant substrate degradation every 24 h. Model reactors were placed in a thermostatic cabinet with hysteresis not exceeding  $\pm 0.5^\circ\text{C}$ . Two days before the end of measuring period, a 30% potassium base (KOH) was introduced to a special container (carrier) fixed inside the tank. It enabled precipitation of carbon dioxide (CO<sub>2</sub>) from the gaseous phase.

In respirometric analyses, computations are based on the equation of perfect gas:

$$n = \frac{p \cdot V}{R \cdot T}$$

where:  $n$  - number of moles of gas [mol],  $p$  - gas pressure [Pa],  $V$  - gas volume [m<sup>3</sup>],  $R$  - universal gas constant, 8.314 J/mol · K,  $T$  - temperature [K].

The content of carbon in the gaseous phase was computed from the following formula:

$$n_{\text{CO}_2+\text{CH}_4} = \frac{p_1 \cdot V_g}{R \cdot T} \cdot 10^{-4}$$

where:  $n_{\text{CO}_2+\text{CH}_4}$  - number of produced moles of carbon dioxide and methane [mol],  $p_1$  - difference in gas pressure in a measuring vessel at the beginning and at the end of experiment [hPa],  $V$  - volume of gaseous phase in the measuring tank [ml],  $R$  - gas constant, 8.314 J/mol · K,  $T$  - temperature of incubation [K],  $10^{-4}$  - conversion factor: conversion of [Pa] to [hPa] and of [m<sup>3</sup>] to [cm<sup>3</sup>].

The content of carbon dioxide in the gaseous phase was computed from the following formula:

$$n_{\text{CO}_2} = \frac{p_1 \cdot V_g - p_2 \cdot (V_g - V_{\text{KOH}})}{R \cdot T} \cdot 10^{-4}$$

where:  $n_{CO_2}$  - number of produced moles of carbon dioxide [mol],  $p_2 - p_N - p_{NaOH}$  [hPa],  $p_N$  - total biogas pressure recorded by the measuring system in the reaction tank [hPa],  $p_{KOH}$  - pressure of gas after KOH introduction to the tank [hPa],  $V_{KOH}$  - volume of KOH solution [cm<sup>3</sup>].

The content of methane in the gaseous phase was computed from the following formula:

$$n_{CH_4} = n_{CO_2+CH_4} - n_{CO_2}$$

Respirometric analyses enabled determining also the rate of biogas production process ( $r$ ) depending on the applied experimental variant. Reaction rate constants ( $k$ ) were determined based on the achieved experimental data with the method of non-linear regression using Statistica 10.0 software. Iterative method was used where in each iterative step a function is replaced by linear differential relative to determined parameters. The coefficient of conformity  $\varphi^2$  was adopted as a measure of curve fit (at determined parameters) to experimental data. This coefficient is a ratio of the sum of squares of deviations of values computed based on the determined function from experimental values, to the sum of squares of deviations of experimental values from the mean value. The lower the value of  $\varphi^2$  coefficient, the better the conformity. At the adopted fitting of the model to experimental points, the coefficient of conformity did not exceed 0.2.

The statistical analysis of results achieved was carried out using STATISTICA 10.0 PL package. The hypothesis on the distribution of each analyzed variable was verified based on W Shapiro-Wilk's test. In order to determine significance of differences between variables, a one-way analysis of variance (ANOVA) was conducted. The homogeneity of variance in groups was determined using the Levene's test. In order to determine the significance of differences between the analyzed variables, use was made of the Tukey's RIR test. In tests, the level of significance was adopted at  $\alpha = 0.05$ .

## Results and discussion

In the first series, the rate of biogas production process reached 68.7 cm<sup>3</sup>/d at the reaction rate constant of 0.13 1/d (Fig. 1, Fig. 2). Biogas production in this series accounted for 449 dm<sup>3</sup>/kg o.d.m. (Fig. 7), with methane content of biogas reaching 28%. Increasing the load to 1.0 g o.d.m./dm<sup>3</sup>·d evoked a significant decrease in methane content of biogas to 26% (Fig. 1). The observed rate of biogas production was at a level of 115.89 cm<sup>3</sup>/d, and the reaction rate constant reached 0.13 1/d (Fig. 2). The quantity of biogas produced was lower by 15% compared with series 1 (Fig. 1). In the third series, technological effects of the process were the lowest (301.52 dm<sup>3</sup> biogas/kg o.d.m.) (Fig. 7). A 5% decrease was noted in the content of methane in biogas produced (Fig. 1). The reaction rate constant reached 0.17 1/d (Fig. 2).

Chen et al run the process of fermentation and co-fermentation of *Spartina alterniflora* with cattle slurry. Their study demonstrated that the process of anaerobic degradation of cordgrass was characterized by a low yield of biogas production. An alternative to this technological solution was co-fermentation of the plant substrate with cattle slurry. The best results were achieved during substrates fermentation at the ratio: 75% of *S. alterniflora* and 25% of cattle slurry. Methane production reached 176.1 cm<sup>3</sup>/g o.d.m., which was

higher by 44% than in the case of fermentation of plant biomass only. The content of methane in biogas was twofold higher than in the case of *S. pectinata* fermentation and reached 63% [10].

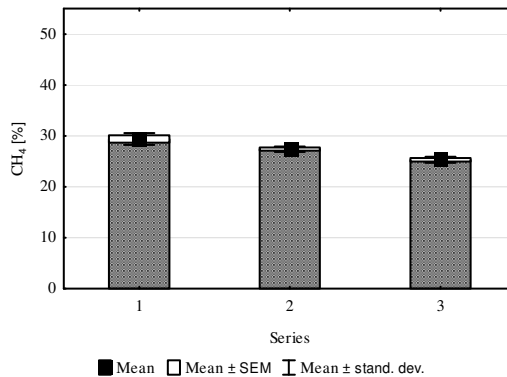

Fig. 1. The methane content in biogas in stage I

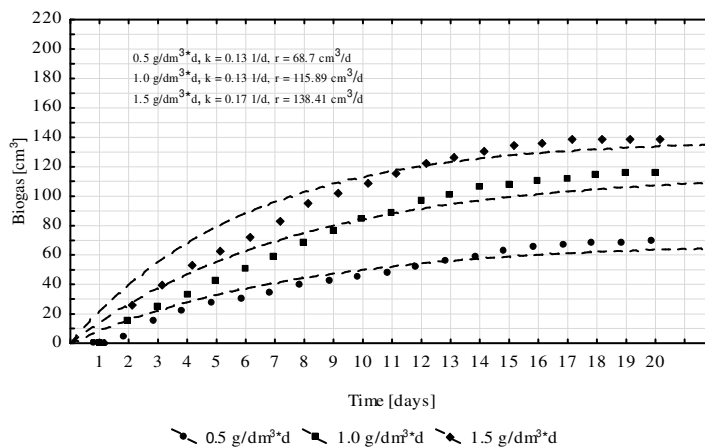

Fig. 2. Biogas production during I stage of experiment

*Spartina pectinata* is not widely applied in processes of anaerobic fermentation. A significantly greater interest among scientists is expressed for *Spartina alterniflora* owing to its abundant occurrence in the USA and China where it is spreading as an invasive plant especially at coastal and boggy areas [4, 11]. Yang et al conducted methane fermentation of *Spartina alterniflora* under mesophilic conditions at a temperature of 36°C, and at the initial concentration of organic compounds in the test reactor at a level of 6%. It enabled achieving biogas production yield of 358 cm<sup>3</sup>/kg o.d.m. The effectiveness of biodegradation after 60 days of the process reached 45%. The content of methane in biogas was increasing successively along with experiment duration from 53 to 62% [12].

Stage II of the study assumed running methane fermentation of the underground part of *S. pectinata*. This stage was distinguished owing to the possibility of nutrients accumulation in *S. pectinata* rhizomes [2]. In each series of this stage, significantly poorer yield of biogas production was observed compared with stage I and stage III of the study. Likewise in the two other stages, the best technological effects of methane fermentation process were recorded in series 1. The percentage content of methane in biogas was higher by 4% on average than in biogas produced from the aerial part of *Spartina pectinata*. A similar dependency was observed in the case of the two other loads applied. The rate of biogas production in the third series accounted for 138.41 cm<sup>3</sup>/d, at the reaction rate constant of 0.17 1/d (Figs. 3 and 4) and quantity of biogas produced at a level of 256.07 dm<sup>3</sup>/kg o.d.m. (Fig. 7).

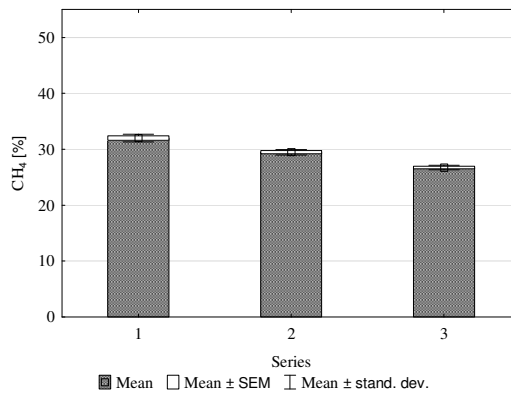

Fig. 3. The methane content in biogas in stage II

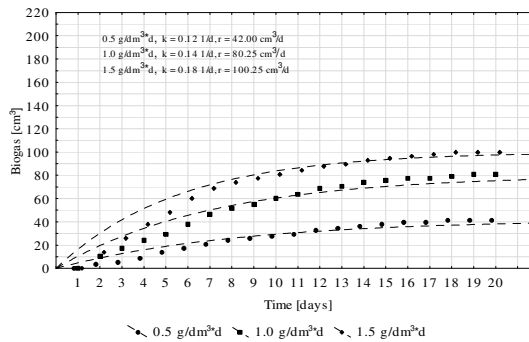

Fig. 4. Biogas production during II stage of experiment

The low effectiveness of the fermentation process noted in this study may be due to the fact that cordgrass is a plant constituted by a lignocellulose complex containing three biopolymers - cellulose, hemicellulose and lignin. During methane fermentation, structure of this type impairs availability of simple compounds to microorganisms which transform

these compounds into methane-rich biogas. Nowadays, processes of pre-treatment of lignocellulose substrates are sought after, that would be economically-substantiated and would effectively improve the process of methane fermentation [13-15].

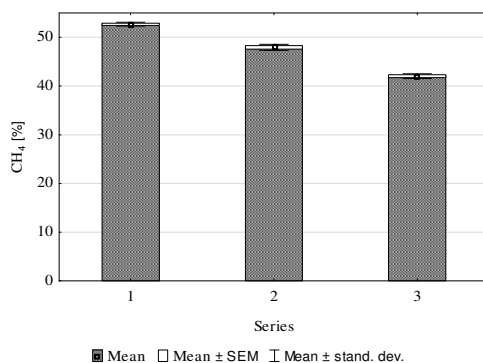

Fig. 5. The methane content in biogas in stage III

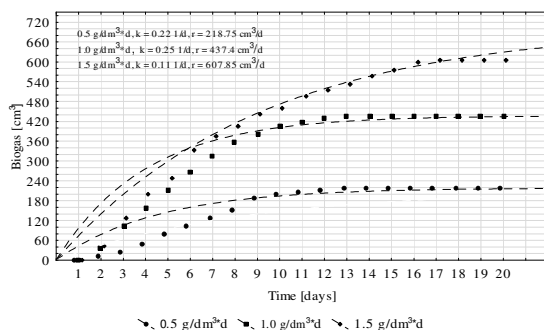

Fig. 6. Biogas production during III stage of experiment

Yang et al in their study demonstrated that co-fermentation of lignocellulose substrates with easily-biodegradable materials may improve the yield of biogas production in anaerobic processes. They carried out processes of *Spartina alterniflora* fermentation and co-fermentation with potatoes in the ratio of 4 : 1 and 6 : 1 of solid organic matter. It turned out that the co-fermentation had a positive effect on the improvement of hemicellulose degradation. In the case of *Spartina alterniflora* fermentation alone, biogas production accounted for 358.5 cm<sup>3</sup>/g o.d.m., whereas upon the addition of the second organic substrate - for 433.6 cm<sup>3</sup>/g o.d.m. and 460.1 cm<sup>3</sup>/g o.d.m. at *Spartina* to potatoes ratio of 4 : 1 and 6 : 1, respectively [16].

In the last stage of the study, model fermentation tanks were fed with maize silage, which allowed to reach the best technological effects. The quantity and composition of biogas achieved during mesophilic fermentation were directly dependent on the applied loading of fermentation tanks with a feedstock of organic compounds. In the first series,

when tank loading reached  $0.5 \text{ g o.d.m./dm}^3 \cdot \text{d}$ , the mean methane content of biogas accounted for 53% at a reaction rate of  $218.75 \text{ cm}^3/\text{d}$  and the reaction rate constant of  $0.20 \text{ dm}^3/\text{d}$  (Figs. 5 and 6). Biogas production after 20 days of the experiment reached  $607.63 \text{ dm}^3/\text{kg o.d.m.}$  (Fig. 7). At the twofold higher loading, *ie*  $1.0 \text{ g o.d.m./dm}^3 \cdot \text{d}$ , the quantity of biogas produced was at a comparable level, with a production rate of  $437.4 \text{ cm}^3/\text{d}$  (Fig. 6). In the second series, the maximum percentage content of methane in biogas reached 48% (Fig. 5). The third series of this experimental stage was characterized by the worst qualitative composition of biogas produced, in which methane constituted barely 42%, and by the lowest process yield accounting for  $422.1 \text{ dm}^3/\text{kg o.d.m.}$  (Fig. 7). The rate anaerobic bacteria metabolites production was at a level of  $607.86 \text{ cm}^3/\text{d}$ , at the reaction rate constant of  $0.22 \text{ dm}^3/\text{d}$  (Fig. 6).

Contemporarily, maize constitutes the most frequently applied substrate in the process of organic wastes biogasing owing to its high yield of biogas production [17]. Weiland conducted the process of methane fermentation of many substrates originating from the agricultural sector. Maize silage turned out to be one of the best fermenting materials which - as estimated by the author - allowed achieving biogas yield of  $410 \text{ m}^3 \text{ CH}_4/\text{Mg o.d.m.}$  [18].

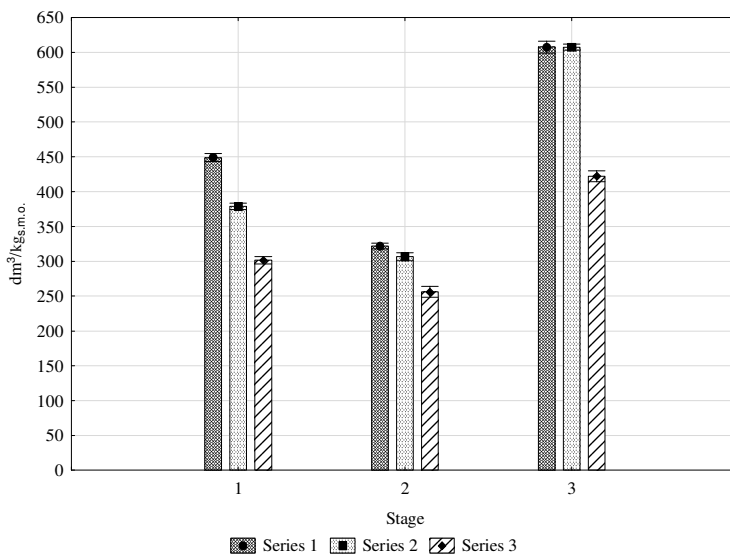

Fig. 7. Biogas production

## Conclusions

Investigations aimed at establishing the technological effectiveness of methane fermentation of *Spartina pectinata* enabled determining the feasibility of its application in biogasing processes and biogas productivity of this substrate compared with other energetic plants. Prairie cordgrass exhibited lower susceptibility to the biodegradation process run under anaerobic conditions by microorganisms than maize silage did. The yield of



biogasing processes turned out to be significantly affected by the applied loading of fermentation tanks with a feedstock of organic matter. The highest biogas production was determined at reaction tanks' loading with a feedstock of organic compounds reaching  $0.5 \text{ g o.d.m./dm}^3 \cdot \text{d}$ . Increased loading caused a reduction in both biogas production and methane content of biogas. Methane fermentation of the aerial part of the plant substrate enabled achieving the highest production yield of gaseous metabolites of bacteria, even though a slightly higher methane content of biogas was noted in the case of cordgrass roots fermentation.

The conducted study confirms the feasibility of applying *Spartina pectinata* in the biogasing process. Effects achieved indicate that this process may be economically-unjustifiable, because technological effects are by 25 and 50% lower than in the case of maize silage fermentation. *Spartina pectinata* is a plant constituted by a lignocellulose complex, which could impede methane fermentation not preceded by pre-treatment that would facilitate degradation of this complex and make easily-digestible simple sugars more available to microorganisms. As indicated by literature data, it would also be advisable to run the co-fermentation process with other substrates used in biogas works.

## References

- [1] Beale CV, Long SP. Seasonal dynamics of nutrient accumulation and partitioning in the perennial c4-grasses *Miscanthus giganteus* and *Spartina cynosuroides*. *Biomass and Bioenergy*. 1997;12(6):419-428. DOI: 10.1016/S0961-9534(97)00016-0.
- [2] Dębowski M, Dudek M, Zieliński M, Grala A. Effectiveness of methane fermentation of Virginia Fanpetals (*Sida hermaphrodita* Rusby) under mesophilic conditions. *Ecol Chem Eng A*. 2012;19(11):1445-1453. DOI: 10.2428/ecea.2012.19(11)140.
- [3] Bauer A, Leonhartsberger Ch, Bösch P, Amon B, Friedl A, Amon T. Analysis of methane yields from energy crops and agricultural by-products and estimation of energy potential from sustainable crop rotation systems in EU-27. *Clean Techn Environ Policy*. 2010;12:153-161. DOI: 10.1007/s10098-009-0236-1.
- [4] Zhi Y, Li H, An S, Zhao L, Zhou C, Deng Z. Inter-specific competition: *Spartina alterniflora* is replacing *Spartina anglica* in coastal China. *Estuarine, Coastal and Shelf Sci*. 2007;74:437-448. DOI: 10.1016/j.ecss.2007.04.026.
- [5] Lu J, Zhang Y. Spatial distribution of an invasive plant *Spartina alterniflora* and its potential as biofuels in China. *Ecol Eng*. 2013;52:175-181. DOI: 10.1016/j.ecoleng.2012.12.107.
- [6] Qin P, Xie M, Jiang Y, Chung CH. Estimation of the ecological-economic benefits of two *Spartina alterniflora* plantations in North Jiangsu. *China Ecol Eng*. 1997;8:5-17. DOI: 10.1016/S0925-8574(96)00227-3.
- [7] Chung CH. Forty years of ecological engineering with *Spartina* plantations in China. *Ecol Eng*. 2006;27:49-57. DOI: 10.1016/j.ecoleng.2005.09.012.
- [8] Wan S, Qin P, Liu J, Zhou H. The positive and negative effects of exotic *Spartina alterniflora* in China. *Ecol Eng*. 2009;35:444-452. DOI: 10.1016/j.ecoleng.2008.05.020.
- [9] Qin P, Xie M, Jiang Y. *Spartina* green food ecological engineering. *Ecol Eng* 1998;11:147-156. DOI: 10.1016/S0925-8574(98)00030-5.
- [10] Chen G, Zheng Z, Yang S, Fang C, Zou X, Zhang J. Improving conversion of *Spartina alterniflora* into biogas by co-digestion with cow feces. *Fuel Process Technol*. 2010;91:1416-1421. DOI: 10.1016/j.fuproc.2010.05.015.
- [11] Liang Y, Zheng Z, Luo X, Si Y, Cao D, Nie E, Cheng B. Lime pretreatment to improve methane production of smooth cordgrass (*Spartina alterniflora*). *Chem Eng J*. 2013;217:337-344. DOI: 10.1016/j.cej.2012.11.135.
- [12] Yang S, Li J, Zheng Z, Meng Z. Characterization of *Spartina alterniflora* as feedstock for anaerobic digestion. *Biomass and Bioenergy*. 2009;33:597-602. DOI: 10.1016/j.biombioe.2008.09.007.

- [13] Liang Y, Zheng Z, Hua R, Luo X. A preliminary study of simultaneous lime treatment and dry digestion of smooth cordgrass for biogas production. *Chem Eng J.* 2011;174:175-181. DOI: 10.1016/j.cej.2011.08.071.
- [14] Liang Y, Zheng Z, Luo XZ, Guo F-H, Wang L, Zhang J. Effect of mesophilic and thermophilic conditions on changes of physicochemical characteristics of smooth cordgrass via dry digestion process. *Chem Eng J.* 2011;168:544-552. DOI: 10.1016/j.cej.2011.01.020.
- [15] Cybulska I, Brudecki G, Rosentrater K, Lei H, Julson J. Catalyzed modified clean fractionation of prairie cordgrass integrated with hydrothermal post-treatment. *Biomass and Bioenergy.* 2012;46:389-401. DOI: 10.1016/j.biombioe.2012.08.002.
- [16] Yang S, Li J, Zheng Z, Meng Z. Lignocellulosic structural changes of *Spartina alterniflora* after anaerobic mono- and co-digestion. *Int Biodeterior Biodegrad.* 2009;63:569-575. DOI: 10.1016/j.ibiod.2009.02.007.
- [17] Nassab ADM, Amon T, Kaul HP. Competition and yield in intercrops of maize and sunflower for biogas. *Ind Crop Prod.* 2011;34(1):1203-1211. DOI: 10.1016/j.indcrop.2011.04.015.
- [18] Weiland P. Production and energetic use of biogas from energy crops and wastes in Germany. *Appl Biochem Biotech.* 2003;109:263-274. DOI: 10.1385/ABAB:109:1-3:263.

## **EFEKTYWNOŚĆ TECHNOLOGICZNA PROCESU FERMENTACJI METANOWEJ SPARTINY PRERIOWEJ (*Spartina pectinata*)**

Katedra Inżynierii Środowiska, Wydział Nauk o Środowisku, Uniwersytet Warmińsko-Mazurski w Olsztynie

**Abstrakt:** Celem prowadzonych badań było określenie możliwości wykorzystania spartiny preriowej (*Spartina pectinata*) w procesach fermentacji metanowej. Efektywność procesu beztlenowego, związaną z ilością oraz składem produkowanego biogazu, a także kinetyką reakcji, określono na podstawie pomiarów respirometrycznych. Fermentacja przebiegała w warunkach mezofilowych przy początkowym obciążeniu komory ładunkiem związków organicznych w zakresie od 0,5 do 1,5 g s.m.o./dm<sup>3</sup> · d. Doświadczenia podzielono na dwa etapy, których kryterium podziału była wykorzystana część testowanej rośliny. W etapie I do modelowych komór fermentacyjnych wprowadzono założone ilości wstępnie przygotowanej części nadziemnej, natomiast w etapie II analizowano możliwość wykorzystania części podziemnej Spartiny preriowej. Przed właściwym procesem beztlenowego rozkładu substrat został poddany mechanicznemu rozdrobieniu w młynie kulowym. W celu porównawczym w tych samych warunkach technologicznych prowadzono proces fermentacji metanowej kiszonki kukurydzy (*Zea mays*), jako podstawowego substratu roślinnego stosowanego w systemach biogazowni rolniczych (etap III). W trakcie badań stwierdzono, iż efektywność procesu fermentacji metanowej była bezpośrednio uzależniona od rodzaju testowanego substratu. Największe efekty technologiczne związane z produkcją biogazu oraz jego składem jakościowym stwierdzono w przypadku testowania kiszonki kukurydzy oraz części nadziemnej Spartiny preriowej. Istotnie niższą wydajność wytwarzania gazowych produktów metabolizmu bakterii beztlenowych zanotowano w etapie, w którym do eksploatowanych komór fermentacyjnych dozowano część podziemną testowanej biomasy roślinnej. Bezpośredni wpływ na przebieg oraz efekty końcowe procesu miało również testowane obciążenie komór ładunkiem suchej masy organicznej.

**Słowa kluczowe:** *Spartina pectinata*, proces beztlenowy, biogaz, fermentacja metanowa, energia odnawialna

Katarzyna GLEŃ<sup>1</sup>, Elżbieta BOLIGŁOWA<sup>2</sup> and Katarzyna ZNÓJ<sup>3</sup>

## EVALUATION OF MANGANESE SEED DRESSINGS EFFECT ON HEALTHINESS OF SPRING BARLEY

### OCENA DZIAŁANIA MANGANOWEJ ZAPRAWY NASIENNEJ NA ZDROWOTNOŚĆ JĘCZMIENIA JAREGO

**Abstract:** The effect of seed dressings: Teprosyn Mn and Raxil Gel 206 on intensification of fungal diseases of culm base, leaves and ears occurrence during the vegetation period of spring barley, Poldek c.v., were assessed in the paper. The applied seed dressings had a notable influence on the intensification of such barley diseases occurrence as: leaf spot caused by *B. sorokiniana* and *Fusarium* spp., barley stripe (*Pyrenophora graminea*), fusarium foot rot (*Fusarium* spp.) and ear spots (*B. sorokiniana*). Raxil Gel 206 and Teprosyn Mn preparations revealed a considerable and approximate efficiency in barley protection against fusarium foot rot and leaf spot. On the plots where grain was treated with these preparations pre-sowing, the share of plants showing symptoms of fusarium foot rot was smaller by half than on the control plots, and also the value of index of leaf infection by *B. sorokiniana* and *Fusarium* spp. decreased significantly. In comparison with Raxil Gel 206 dressing, manganese Teprosyn Mn dressing showed a significantly higher effectiveness in reducing barley stripe occurrence. It has been evident as a 23.36% lower share of plants infected by *Pyrenophora graminea* and 14.37% lower value of infection index.

**Keywords:** barley, fungal diseases, Teprosyn Mn

#### Introduction

In Poland, cereal cultivation including barley remains the main branch of plant production. Spring barley cultivars are particularly valuable since they can be cultivated after plants with long vegetation period [1]. Barley grain finds numerous applications in animal nutrition and is a valued raw material for grit manufacturing, whereas malting barley forms are used for malt production [1-3].

Increasing acreage of this species and other cereals cultivated in the European countries has a significant influence on the species composition and harmfulness of numerous pathogen species. The most dangerous are pathogens carried with sowing material, such as: *Bipolaris sorokiniana*, *Fusarium* spp., *Pyrenophora graminea*, which contribute to seedling rot or barley leaf spot. Moreover, their polyphagous character makes them the main source of infection also for the other species of consecutive crops [4]. Therefore, it is necessary to protect these crops against infectious diseases. A method used already in the antiquity which nowadays is counted among the most environment friendly ones is chemical seed material dressing [5]. Using qualified and carefully dressed seed material largely guarantees generating good emergencies and in result also high yields [6]. Moreover, seed dressing is the most efficient and cheapest measure of controlling fungal diseases carried with sowing material [7, 8].

---

<sup>1</sup> Department of Agricultural Environment Protection, University of Agriculture in Krakow, al. A. Mickiewicza 21, 31-120 Kraków, email: rrglen@cyf-kr.edu.pl

<sup>2</sup> email: rrboligl@cyf-kr.edu.pl

<sup>3</sup> email: rrznoj@cyf-kr.edu.pl

Teprosyn Mn manganese seed dressing, manufactured by British Phosyn Chemicals Ltd. firm, which has been recently available on the market, aims mainly at stimulating the development of cereal root system and improvement of general crop condition. However, the available literature offers no information about Teprosyn Mn effect on plant healthiness.

The work aims at an assessment of the influence of Teprosyn Mn and Raxil Gel 206 on the occurrence of culm base, leaf and ear fungal diseases in spring barley, Poldek c.v.

## Materials and methods

A field experiment on spring malting barley, Poldek c.v. was conducted in 2009-2010 in Jatrzebiec (Lezajsk county, Podkarpackie province). The experiment was set up on the soil on podzol bedrock, classified to IV soil quality class of good rye complex. A single factor field experiment using seed dressings: Raxil gel 206 (tiuram 200 g in 1 dm<sup>3</sup> of medium - a compound from dithiocarbamate group and tebukonazol 6 g/dm<sup>3</sup>) and Teprosyn Mn (27.4% of manganese) was conducted in randomised block design in three replications. Each year buckwheat was the forecrop for barley. Polifoska 8 mineral fertilizer dosed 250 kg · ha<sup>-1</sup> was sown in spring. It supplied 20 N kg · ha<sup>-1</sup>, 60 P<sub>2</sub>O<sub>5</sub> kg · ha<sup>-1</sup>, 60 K<sub>2</sub>O kg · ha<sup>-1</sup> and 22.5 SO<sub>3</sub> kg · ha<sup>-1</sup>. Immediately before sowing individual portions of spring barley were treated with Raxil Gel 206 and Teprosyn Mn seed dressings. The control was untreated grain. Spring barley was sown to the 20 m<sup>2</sup> plots. The norm of barley sowing, 140 kg · ha<sup>-2</sup> was the same for all combinations. During vegetation all barley plots were protected against weed infestation by using Puma Universal 069 EW herbicide dosed 1 dm<sup>3</sup> · ha<sup>-1</sup> against annual weeds. Moreover, urea dosed 30 N kg · ha<sup>-1</sup> was applied to supplement the requirement for nitrogen.

Assessment of barley healthiness was conducted on 25 plants randomly selected from each plot. At BBCH 51-59 phase assessed was occurrence of culm base diseases, using 5<sup>o</sup> scale, on which: 0 - culm base or roots without infection symptoms, 5 - culm base or roots are rotten. On the other hand, at BBCH 75 (milk-wax stage of barley grain) infectious diseases were assessed on leaves and ears. The intensity of each disease was expressed by parameters, *ie*: medium infection on 9<sup>o</sup> scale (where: 9 - no disease symptoms, 1 - over 50% of leaf blade covered by disease symptoms) [9], percent share of infected plants and infection index computed according to the formula:

$$I_p = \frac{\sum(a \cdot b) \cdot 100}{Nn}$$

where:  $I_p$  - infection index,  $a$  - number of plants with determined degree of infection,  $b$  - degree of infection,  $N$  - total number of studied plants,  $n$  - the highest degree applied on the scale.

The results were subjected to the analysis of variance and the significance of differences was verified by t-Student test on significance level  $\alpha = 0.05$ .

## Results and discussion

On the basis of the experiments it was found that intensification of culm base disease, leaf spot and stripes, and helmintosporiosis of spring barley ears, Poldek c.v. depended on the vegetation season (Table 1).

Table 1  
Effect of vegetation season on infection index by pathogens of spring barley, poldek c.v.

Diseases	Year	Raxil Gel 206	Teprosyn Mn	Control	Mean	LSD (0.05)
Culm base diseases						
Helmintosporiosis ( <i>Drechslera sorokiniana</i> )	2009	28.00	20.20	32.3	26.83	5.10
	2010	5.55	6.40	6.50	6.15	
LSD (0.05) for year x seed dressing		r.n.				
Fusarium foot rot ( <i>Fusarium</i> spp.)	2009	5.40	4.00	15.36	8.25	2.8
	2010	4.11	2.52	8.7	5.11	
LSD (0.05) for year x seed dressing		4.37				
Leaf diseases						
Leaf spot ( <i>Bipolaris sorokiniana</i> , <i>Fusarium</i> spp.)	2009	10.80	8.70	26.00	15.16	5.09
	2010	5.00	0.94	6.02	3.98	
LSD (0.05) for year x seed dressing		6.32				
Barley leaf stripe ( <i>Pyrenophora graminea</i> )	2009	40.1	27.5	42.4	36.3	7.14
	2010	20.44	4.62	16.76	13.94	
LSD (0.05) for year x seed dressing		10.54				
Net blotch of barley leaves ( <i>Pyrenophthora teres</i> )	2009	23.60	21.60	22.03	22.41	r.n.
	2010	15.14	19.52	14.87	16.51	
LSD (0.05) for year x seed dressing		r.n.				
Ear diseases						
Fusarium ear infection ( <i>Fusarium</i> spp.)	2009	3.90	5.75	3.42	4.35	r.n.
	2010	3.04	2.71	1.98	2.58	
LSD (0.05) for year x seed dressing		r.n.				
Fusarium ear spots ( <i>Bipolaris sorokiniana</i> )	2009	8.11	30.72	32.51	23.78	6.85
	2010	0.20	24.8	21.99	15.66	
LSD (0.05) for year x seed dressing		11.03				

Significantly higher barley infection by fungi causing the above-mentioned diseases was observed in 2009 than in 2010. Rainfall deficiency in the second and third decade of April and in the first decade of May 2009, as well as high air temperatures considerably worsened moisture conditions in soils leading to inhibition of growth and development of barley plants. On the other hand, the weather conditions at the beginning of 2010 vegetation period favoured plant development. In the first place, at slightly lower temperatures in April and May plants had sufficient amount of water. Prolonging period of germination and emergences obviously favoured spring barley infections by soil fungi causing culm base diseases (*Bipolaris sorokiniana* and *Fusarium* spp.). The outcome was also more intensive than in 2010 leaf and ear infection by necrophytic fungi: *Pyrenophthora teres*, *B. sorokiniana* and *Fusarium* spp., which infect weak plant organs. Both in Poland and worldwide *B. sorokiniana* - syn. *Cochliobolus sativus* is regarded as the main cause of take-all diseases in cereals, particularly spring barley [1, 10-14]. The species attacks all plant organs and is a dangerous pathogen of barley at all stages of its development. The experiments demonstrated that irrespective of the year of cultivation *B. sorokiniana* infected on average 90.21% of spring barley, Poldek c.v. ears (Tables 2, 3). Delayed germination and emergence of barley due to water deficit is especially advantageous for development of *Pyrenophthora graminea* - the cause of barley leaf stripes [15]. In the presented experiment the plants showing symptoms of the disease constituted 76.9%.

Table 2

Barley culm base diseases depending on applied seed dressing (means for years)

Infection parameters	Raxil Gel 206	Teprosyn Mn	Control	Mean	LSD <sub>0.05</sub>
Helmintosporiosis ( <i>Drechslera sorokiniana</i> )					
Share of infected plants [%]	70.75	100.00	90.10	86.95	21.55
Mean degree of infection	3.47	3.78	3.24	3.49	r.n.
Infection index	16.78	13.30	19.40	16.49	r.n.
Fusarium foot rot ( <i>Fusarium</i> spp.)					
Share of infected plants [%]	16.34	16.26	35.01	22.54	5.17
Mean degree of infection	3.77	3.90	3.41	3.69	0.27
Infection index	4.77	3.26	12.03	6.68	6.05

Table 3

Barley ear diseases depending on applied seed dressing

Infection parameters	Raxil Gel 206	Teprosyn Mn	Control	Mean	LSD <sub>0.05</sub>
Fusariosis of ears ( <i>Fusarium</i> spp.)					
Share of infected plants [%]	23.57	28.62	19.83	24.01	r.n.
Mean degree of infection	7.65	7.62	7.69	7.65	r.n.
Infection index	3.47	4.23	2.70	3.46	r.n.
Leaf spot disease ( <i>Bipolaris sorokiniana</i> )					
Share of infected plants [%]	74.00	96.63	100.00	90.21	17.01
Mean degree of infection	7.48	5.76	5.73	6.32	1.22
Infection index	4.15	27.76	27.25	19.72	12.54

Conducted research revealed that, irrespectively of the vegetation season Raxil gel 206 and Teproxyn Mn seed dressings significantly reduced barley leaf infection by *B. sorokiniana* and *Fusarium* spp. as was demonstrated by lower than on the control plot values of leaf infection parameters (Table 4). Moreover, the results of leaf protection against these pathogens were on a comparable level for both seed dressings. Conducted statistical analysis demonstrated that in comparison with Teproxyn Mn manganese seed dressing, Raxil Gel 206 dressing notably reduced the share of infected plants, their mean degree of infection and twice decreased value of infection index by *P. graminea*. On the other hand, approximate and non-diversified significantly intensification of barley ear net blotch (*P. teres*) was registered on all experimental plots (Table 4). Values of infection index for all combinations fell within a very small range 18.45-20.56.

Table 4

Barley leaf diseases depending on applied seed dressing (mean for years)

Infection parameters	Raxil Gel 206	Teprosyn Mn	Control	Mean	LSD <sub>0.05</sub>
Fusarium leaf spot ( <i>Bipolaris sorokiniana</i> , <i>Fusarium</i> spp.)					
Share of infected plants [%]	26.15	19.84	35.80	27.26	7.05
Mean degree of infection	8.29	8.55	7.50	8.11	0.55
Infection index	7.90	4.82	16.01	9.57	4.18
Barley leaf stripe ( <i>Pyrenophora graminea</i> )					
Share of infected plants [%]	81.22	59.45	90.01	76.89	21.33
Mean degree of infection	6.54	7.61	6.23	6.79	0.90
Infection index	30.27	16.06	29.58	25.30	8.31
Barley leaf net blotch ( <i>Pyrenophthora teres</i> )					
Share of infected plants [%]	84.57	91.29	79.55	85.14	r.n.
Mean degree of infection	7.12	6.98	7.26	7.12	r.n.
Infection index	19.37	20.56	18.45	19.46	r.n.

A potential source of infection for *P. teres*, *B. sorokiniana* and *Fusarium* spp. are infected kernels, stubble, straw residue, soil and proximity of infected plantations [16]. In the Authors' own investigations seed dressings revealed a considerable efficiency regarding leaf spot. Still, its lack was noticeable for barley leaf net blotch. The only source of barley leaf net blotch is infected grain to which *P. graminea* fungus penetrates during barley blooming period [15]. The number of infected kernels used for sowing determines plant healthiness during vegetation period. On the control plot the share of plants showing these disease symptoms was very high, reaching 90% (Table 4). Presented research demonstrated that Raxil Gel 206 seed dressing in which active substance are compounds from dithiocarbamates and triazoles group did not limit *P. graminea* development on the leaves of tested barley cultivar. On the other hand, application of Teprosyn Mn manganese seed dressing, which is treated rather as seed fertilizer than fungicide, produced surprising results. In combinations with this preparation, the share of plants showing leaf stripe symptoms was on average 21.7% lower, whereas average degree of their infection was lower by 1.07 (Table 4). To some extent, reduced development of barley leaf stripe disease following application of Teprosyn Mn seed dressing may be explained by the fact that it is applied in the first place to provide a young plant with possibility of intensive development and especially forming a strong root system. Manganese available at seedling stage beneficently affects development of capillary roots. On the other hand, more intensive barley development might have in some way eliminated the effects of *P. graminea* fungus presence in kernels. Fertilizer preparations contain substances which have a toxic effect on phytopathogens. In view of the foregoing, reducing the occurrence of barley leaf stripe might have been the outcome of direct fungistatic effect of manganese on *P. graminea* fungus.

Helminthosporiosis (*Drechslera sorokiniana*) occurred more frequently on spring barley culm base than fusarium rot (Table 4). The number of plants showing these disease symptoms was significantly higher on the plots where the seeds were treated with Teprosyn Mn dressing than Raxil Gel 206 (Table 2). Statistical analysis revealed a marked influence of seed dressings on limiting intensity of fusarium foot rot (Table 2). After the application of tested seed dressings a double decrease in the number of plants showing this disease symptoms and significantly decreased values of the other indices of healthiness were registered. Also other authors [16, 17] reported a considerable effectiveness of Raxil Gel 206 in cereal protection against *Fusarium* ssp. and other pathogens causing culm rot.

Cereal ear diseases to great extent result from earlier occurrence of pathogens on other plant organs. *Fusarium* spp. and *B. sorokiniana* fungi settled barley leaves, however development of spot disease caused by *B. sorokiniana* on ears was more intensive than fusariosis (Table 3). Applied seed dressings did not have any significant influence on ear infection by *Fusarium* ssp., but notably affected all parameters of infection by *B. sorokiniana*. Significantly lower percentage of ears showing only slight spot disease symptoms were registered in the combination where the grain was treated with Raxil Gel 206 preparation pre-sowing (Table 3). On the other hand, intensity and degree of barley ear infection by *B. sorokiniana* on the plot where Teprosyn Mn was applied and on the control plot were on a similar and very high level.

## Conclusions

1. Independently of applied seed dressing leaf stripe and net blotch occurred most intensively on leaves of tested barley whereas on culm base the most frequent was helminthosporiosis and on ears fusariosis.
2. Tested seed dressings had a significant influence on intensified occurrence of barley diseases, such as: leaf spot (*B. sorokiniana* and *Fusarium* spp.), barley leaf stripe (*Pyrenophora graminea*), fusarium foot rot (*Fusarium* ssp.) and ear spot (*B. sorokiniana*).
3. Raxil Gel 206 and Teprosyn Mn seed dressings revealed a high and similar efficiency in barley protection against fusarium foot rot and leaf spot (*B. sorokiniana* and *Fusarium* ssp. complex).
4. Teprosyn Mn manganese dressing in comparison with Raxil Gel 206 was characterized by significantly higher effectiveness in limiting barley leaf stripe occurrence. It was evidenced by a 23.36% smaller share of plants infected by *P. graminea* and by 14.37 lower value of infection index.

## References

- [1] Wiewióra B. Comparison of selected traits of naked and husked seeds of spring barley. *Pamięt. Puław.* 2006;142:547-560.
- [2] Bhatti RS. The potential of Hull-less barley - a review. *Cereal Chem.* 1986;63:97-103.
- [3] Boros D, Rek-Cieplý B, Cyran M. A note on the composition and nutritional value of hulless barley. *J Animal Feed Sci.* 1996;5:417-424.
- [4] Wiewióra B. Diseases occurrence in crop of spring barley in the years 2000-2002 and their influence on yield and seed health. *Pamięt. Puław.* 2007;146:139-154.
- [5] Jańczak C, Pawlak A. Seed dressing. *Agrotechnology.* 2006;8:14-17.
- [6] Wiewióra B. The effect of seed treatment on seed health, quality and yield of spring barley Part I. The effect of seed treatment on fungi contaminated seed of spring barley, its germination and vigour. *Biul IHAR.* 2003;228:89-94.
- [7] Korbas M, Kubiak K. Dressing of spring cereals. *Farm Guide.* 1996;3:21.
- [8] Juszcak M, Rogalińska M, Krasiński T. Dressing the cheapest cereals prophylaxis. *Prog Plant Protect./Post Ochr Roślin.* 2001;41(2):604-606.
- [9] Kaczyński L, Zych J, Behnke M, Lewandowska B, Szymczyk R. COBORU; 1998.
- [10] Łacicowa B, Pięta D, Kiecana I. Susceptibility of several cultivars of spring barley (*Hordeum vulgare L.*) on root rot diseases. *Biul IHAR.* 1993;37(5/6):37-43.
- [11] Łacicowa B, Pięta D. The effectiveness of some chemical mortars in preventing root rot diseases of spring barley (*Hordeum vulgare L.*). *Ann Univers Mariae Curie-Skłodowska Lublin.* 1998;6:185-198.
- [12] Kumar J, Schafer P, Huckelhoven R, Langen G, Baltruschat H, Stein E, et al. Bipolaris sorokiniana, a cereal pathogen of global concern: cytological and molecular approaches towards better control. *Mol Plant Pathol.* 2002;3(4):185-195.
- [13] Morejon KR, Moraes MHD, Bach EE. Identification of Bipolaris bicolor and Bipolaris sorokiniana on wheat seeds (*Triticum aestivum L.*) in Brazil. *Brazilian J of Microbiol.* 2006;37:247-250.
- [14] Baturo A, Sadowski C, Kuś J. Healthiness and fungus composition of barley roots under organic, integrated and conventional farming systems. *Acta Agrobot.* 2002;55(1):17-26.
- [15] Kryczyński S, Weber Z. *Phytopathology.* Poznań: PWRiL; 2011.
- [16] Kryczyński S. *Plant diseases in agricultural crops.* Warszawa: SGGW; 2010.
- [17] Parylak D, Wojtala L. Application of reduced dose of seed treatment product Latitude 125 fs (silthiofam) in winter wheat continuous cropping. *Prog Plant Protect./Post Ochr Roślin.* 2007;47(2):240-243.
- [17] Kurowski T., Majchrzak B., Jaźwińska E., Wysocka U. Effect of seed dressing on the occurrence of root and foot rot in winter wheat. *Prog Plant Protect./Post Ochr Roślin.* 2007;47(21):166-169.



## OCENA DZIAŁANIA MANGANOWEJ ZAPRAWY NASIENNEJ NA ZDROWOTNOŚĆ JĘCZMIENIA JAREGO

Katedra Ochrony Środowiska Rolniczego, Uniwersytet Rolniczy w Krakowie

**Abstrakt:** W pracy oceniono wpływ zapraw nasiennych: Teprosyn Mn i Raxil Gel 206 na występowanie chorób grzybowych podstawy źdźbła, liści i kłosów jęczmienia jarego odmiany Poldek. Testowane preparaty istotnie modyfikowały nasilenie plamistości liści (kompleks grzybów *B. sorokiniana* i *Fusarium* spp.), pasiastość liści jęczmienia (*P. graminea*), fuzaryjną zgorzel podstawy źdźbła (*Fusarium* spp.) oraz plamistość kłosów (*B. sorokiniana*). Preparaty Raxil Gel 206 i Teprosyn Mn wykazały dużą skuteczność w ochronie jęczmienia przed fuzaryjną zgorzelą podstawy źdźbła i plamistością liści. Udział roślin z objawami fuzaryjnej zgorzeli był o połowę mniejszy niż w obiekcie kontrolnym, istotnie obniżyła się również wartość indeksu porażenia liści przez *B. sorokiniana* i *Fusarium* spp. Zaprawa Teprosyn Mn wykazała istotnie większą skuteczność w ograniczeniu występowania pasiastości liści jęczmienia. Wyrazem tego jest o 23,4% mniejszy udział roślin porażonych przez *P. graminea* oraz o 14,4 niższa wartość indeksu porażenia.

**Słowa kluczowe:** jęczmień, choroby grzybowe, Teprosyn Mn



Janina GOSPODAREK<sup>1</sup>

## BIOREMEDIATION OF SOIL POLLUTED WITH OIL DERIVATIVES AND ITS EFFECT ON COLEOPTERA, CARABIDAE OCCURRENCE

### ODDZIAŁYWANIE BIOREMEDIACJI GLEBY ZANIECZYSZCZONEJ ROPOPOCHODNYMI NA WYSTĘPOWANIE BIEGACZOWATYCH (COLEOPTERA, CARABIDAE)

**Abstract:** The investigations were conducted to determine the effect of oil derivatives (petrol, diesel fuel and used engine oil) during the process of their bioremediation on dynamics of Carabidae occurrence. Carabidae activity is to various extent limited in conditions of soil pollution with oil derivatives depending on the kind of applied substance. Petrol reveals negative effect for the shortest period of time (*ca* 3 months), whereas both diesel oil and engine oil act for a much longer period: diesel fuel may have a negative effect for 12 months, whereas engine oil for 15 months from the time of soil pollution. The process of bioremediation of soil polluted with oil derivatives does not influence Carabiade activity during the first five months after its initiation, whereas in the later period (after a year) it may contribute to increased activity of Carabidae in conditions of soil polluted with diesel fuel, at the same time neutralizing the negative effect of the above-mentioned substance.

**Keywords:** oil derivatives, soil, bioremediation, Carabidae

#### Introduction

Carabidae are often mentioned among invertebrates as indicators of soil pollution. Their occurrence was analyzed among others with reference to the efficiency of remediation of soils for many years subjected to anthropogenization [1], as well as on soils polluted with heavy metals [2-4]. The available literature contains little information about the influence of oil derivatives on these organisms. Carabidae were one of invertebrate groups studied from the perspective of domestic sewage effect and oil spills on edaphic invertebrates occurrence on periodically flooded stream banks [5]. Their considerably limited of their number was found in samples from the most polluted area. Carabidae activity in conditions of soils polluted with petrol, diesel fuel or engine oil also became considerably limited [6]. A diversification of response was noted depending on the kind of pollution but also on the beetle species.

The efficiency of microbiological biopreparations application in order to accelerate the process of natural recultivation of the ground polluted with oil derivatives was proved [7]. However, there is still no information how the bioremediation process affects the organisms living on the soil surface.

The work aimed at investigating the effect of oil derivatives during the process of their bioremediation on dynamics of Carabidae occurrence.

#### Materials and methods

Experiment was conducted at the Experimental Station of the University of Agriculture in Krakow situated in Mydlniki near Krakow, Poland. It was conducted in four replications

<sup>1</sup> Department of Agricultural Environment Protection, University of Agriculture in Krakow, al. A. Mickiewicza 21, 31-120 Kraków, phone 12 662 44 00, email: rrjgospo@cyf-kr.edu.pl

and comprised the following objects in two series (with bioremediation and without bioremediation): 1. Control - unpolluted soil (C); 2. Soil artificially polluted with petrol (P); 3. Soil artificially polluted with diesel fuel (DF) and 4. Soil artificially polluted with used engine oil (EO). In autumn 2009, the indigenous soil was placed in cubic containers (1 m<sup>3</sup>) specially adapted for this purpose. The containers were placed into the ground. Doses of 6000 mg of oil derivative per 1 kg soil d.m. were applied in June 2010 by pouring onto soil in containers. After one week a half of the containers with experimental soil were subjected to bioremediation using a ZB-01 preparation designed for bioremediation of soils polluted with oil derivatives. Detailed description of experiment was presented in other paper [8]. Coleoptera Carabidae were trapped using Barber's traps placed in the central part of each container (a 0.9 dm<sup>3</sup> jar dug in level with the ground surface and covered against rainfall water by a plastic roof). The traps were emptied once a week in growing seasons during two years from the moment of soil contamination (until end of June 2012). Statistical computations were conducted using Statistica 9.0 PL programme. Means were differentiated using LSD Fisher test on significance level  $\alpha = 0.05$ .

## Results and discussion

Dynamics of the number of insect capturings conducted during the period of investigations points to a higher activity of Carabidae during the late summer (August, beginning of September). The number of specimens trapped at that time reached even 20 per trap during a week, whereas in the other period of time it was only several pieces (Figs. 1-3). During capturing conducted in the 2010 season, *ie* during the period from 0 to 5 months from the moment of pollution, a higher number of captured insects might be observed in the unpolluted soil (Fig. 1) almost during the whole time. Dynamics of insect capturing in conditions of polluted soil pointed to particularly negative effect of applied engine and diesel oils. Activity of Carabidae in conditions of soil subjected to bioremediation and in non-remediated soil was similar. Statistical analysis conducted in subsequent months after soil pollution in 2010 revealed significantly less Carabidae trapped in conditions of soil polluted with petrol for the first three months and in diesel oil contaminated soil for 4 months (Table 1) in comparison with unpolluted soil. In soil polluted with engine oil, significant differences were registered in the months from the second to the fourth. In the fifth month from the moment of pollution, *ie* in October, very low activity of Carabidae was observed and therefore no significant differences were noted between studied objects. In none of the above-mentioned months was any marked effect of applied bioremediation noted on the number of trapped Carabidae. The dependencies described above were also reflected in the average per season number of captured Carabidae (Fig. 4).

In the 2011 season, *ie* between 11 and 16 months from the moment of soil pollution, the dynamics of Carabidae activity in the individual objects was different in comparison with the previous year (Fig. 2). The main difference concerned the object where the soil was polluted with petrol. In this case for the whole season the number of captured insects was similar to unpolluted soil. Also an increase in the number of trapped insects was observed in conditions of soil polluted with diesel oil and subjected to remediation. Statistical analysis of the number of trapped insects in the individual months of 2011 revealed a lack of significant effect of soil pollution with petrol (Table 1). A negative effect

of diesel fuel was statistically proved still in the 11<sup>th</sup> and 12<sup>th</sup> month after the soil contamination. In case of engine oil a significant, in comparison with the control, decline in the number of captured insects was noted in the 11<sup>th</sup>, 12<sup>th</sup> and 15<sup>th</sup> month from the moment of soil contamination, however much fewer of these invertebrates were trapped also in the other months of 2011. Applied bioremediation of the petrol soil polluted contributed to a decrease in the number of Carabidae trapped in some months (11<sup>th</sup> and 15<sup>th</sup>), but only to the level similar as in conditions of unpolluted soil. During whole period of the insect capturing conducted in the 2011 season, more numerous Carabidae were noted in the traps placed in the soil contaminated with diesel fuel and subjected to bioremediation than in the soil where this measure was not applied, therefore the analysis of the data for the whole 2011 season revealed a marked positive effect of this measure (Fig. 4). On the other hand no significant effect of bioremediation on Carabidae activity was noticed in conditions of soil polluted with engine oil.

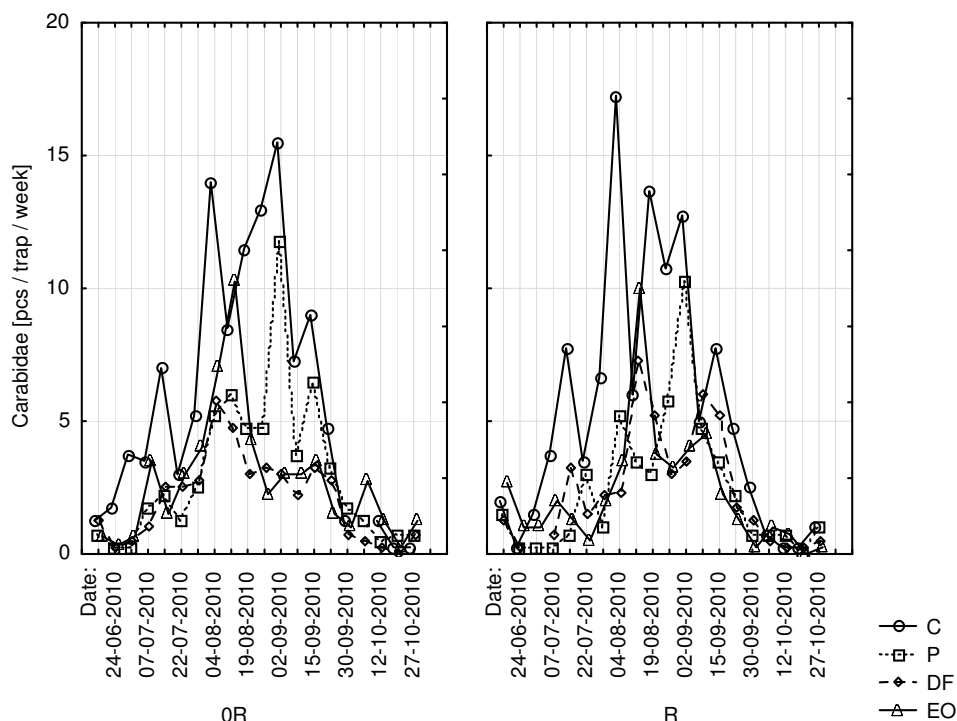

Fig. 1. Course of dynamics of Carabidae occurrence trapped using Barber's traps in 2010. EO - soil contaminated with used engine oil, DF - soil contaminated with diesel fuel, P - soil contaminated with petrol, C - unpolluted soil, OR - series without bioremediation, R - series with bioremediation

In the 2012 season the insects were captured in May and June (*ie* in the 23<sup>rd</sup> and 24<sup>th</sup> month after the moment of soil contamination). Activity of Carabidae in this period was

low (Fig. 3). No marked differences were registered among the studied objects dependent on the kind of pollution or applied bioremediation.

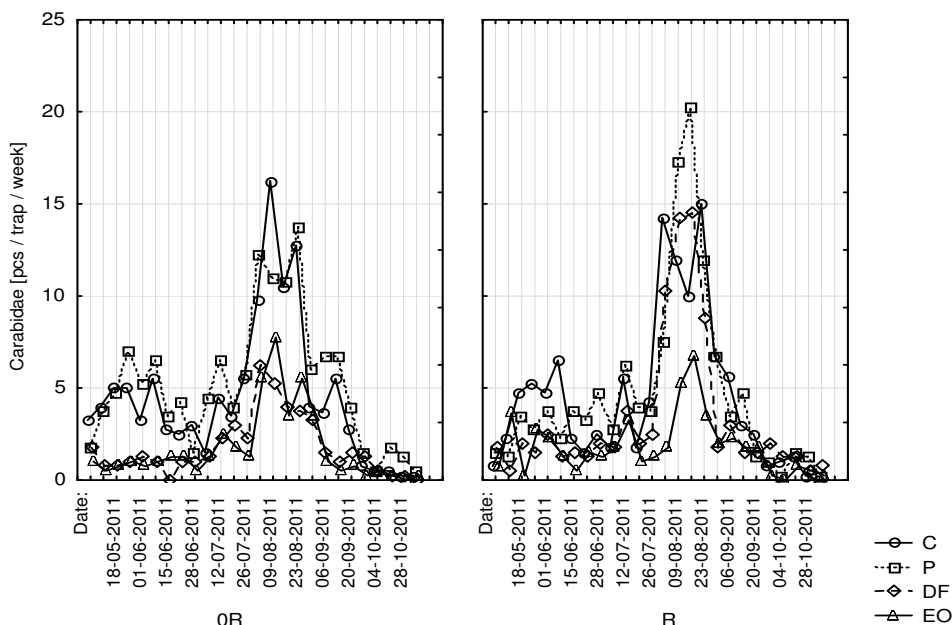

Fig. 2. Course of dynamics of Carabidae occurrence trapped using Barber's traps in 2011. The symbols as in Figure 1

In an extensive literature on the effect of oil spills on aquatic invertebrates diversified responses of the animals are emphasized, which depend on their taxonomic position, way of feeding, age, *etc.* [9, 10]. Despite the fact that terrestrial arthropods are regarded as efficiently metabolizing harmful components of oil derivatives, among others PAHs [11], still it does not denote that this type of pollution has no effect on their occurrence. While analyzing occurrence of invertebrates in soil samples from the banks of seasonally flooding streams and to various extent exposed to pollution, Couceiro et al [5] found even 7 times fewer representatives of Carabidae in the samples from the banks of a stream exposed to pollution due to oil spills in comparison with the stream not prone to pollution, whereas in the samples from the area close to a stream exposed to pollution with domestic sewage they were about twice less numerous. Using of pitfall traps is regarded and commonly reported as a good indicator of terrestrial invertebrate activity [1, 12]. In previous investigations using them, at about thrice lower dose of applied oil derivatives, a decrease in the number of captured Carabidae was observed for a period of 4 months from the moment of soil contamination. Like in the presented research, Carabidae avoided contact with petrol polluted soil for the shortest period of time [6]. On the other hand, 2 and 3 years after the moment of soil pollution with oil derivatives in result of a road accident, no negative effect of these substances on general activity of Carabidae was registered [13].

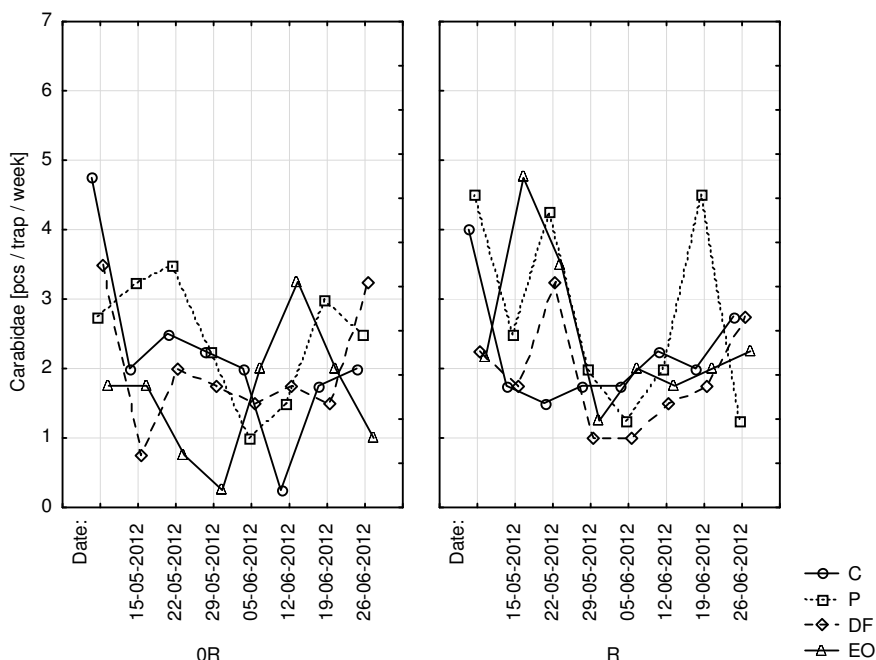

Fig. 3. Course of dynamics of Carabidae occurrence trapped using Barber's traps in 2011. The symbols as in Figure 1

Table 1  
Occurrence of Carabidae trapped using Barber's traps in individual months after soil contamination.  
The symbols as in Figure 1

Number of months from the moment of soil contamination	Carabidae [pcs/trap/month]							
	Control		Petrol		Diesel fuel		Engine oil	
	0R	R	0R	R	0R	R	0R	R
1	10.25 b*	7.50 ab	3.00 a	2.35 a	3.00 a	2.25 a	5.17 ab	6.67 ab
2	27.00 b	35.17 b	11.25 a	10.00 a	13.50 a	9.25 a	15.50 a	7.25 a
3	48.50 c	43.17 bc	27.25 ab	22.50 a	14.00 a	19.00 a	19.75 a	21.00 a
4	22.25 c	20.00 bc	15.25 abc	11.25 a	9.00 a	14.25 ab	9.00 a	8.25 a
5	1.75 a	2.25 a	3.25 a	2.50 a	1.50 a	1.50 a	5.50 a	2.00 a
11	20.50 cd	17.75 cd	22.50 d	12.75 bc	5.50 ab	8.25 ab	4.00 a	9.54 ab
12	13.75 cd	12.75 bcd	15.75 d	14.00 cd	3.00 a	6.00 abc	4.00 ab	4.50 ab
13	15.00 ab	13.25 ab	20.75 b	16.75 ab	8.75 a	10.00 ab	6.75 a	7.25 a
14	53.25 a	58.00 a	53.75 a	63.75 a	22.50 a	49.50 a	25.74 a	19.25 a
15	12.67 bc	11.92 bc	19.00 c	10.25 b	5.25 ab	7.75 ab	2.50 a	6.00 ab
16	1.50 ab	2.50 ab	4.00 b	3.25 ab	1.00 a	3.50 ab	1.00 a	1.50 ab
23	11.50 ab	9.00 ab	11.75 b	13.25 b	8.00 ab	8.25 ab	4.50 a	11.58 ab
24	6.00 a	8.75 a	8.00 a	9.00 a	8.00 a	7.00 a	8.25 a	8.00 a

\*Means in lines marked with the same letters do not differ significantly according to LSD test at  $\alpha = 0.05$ ; factors contamination x remediation

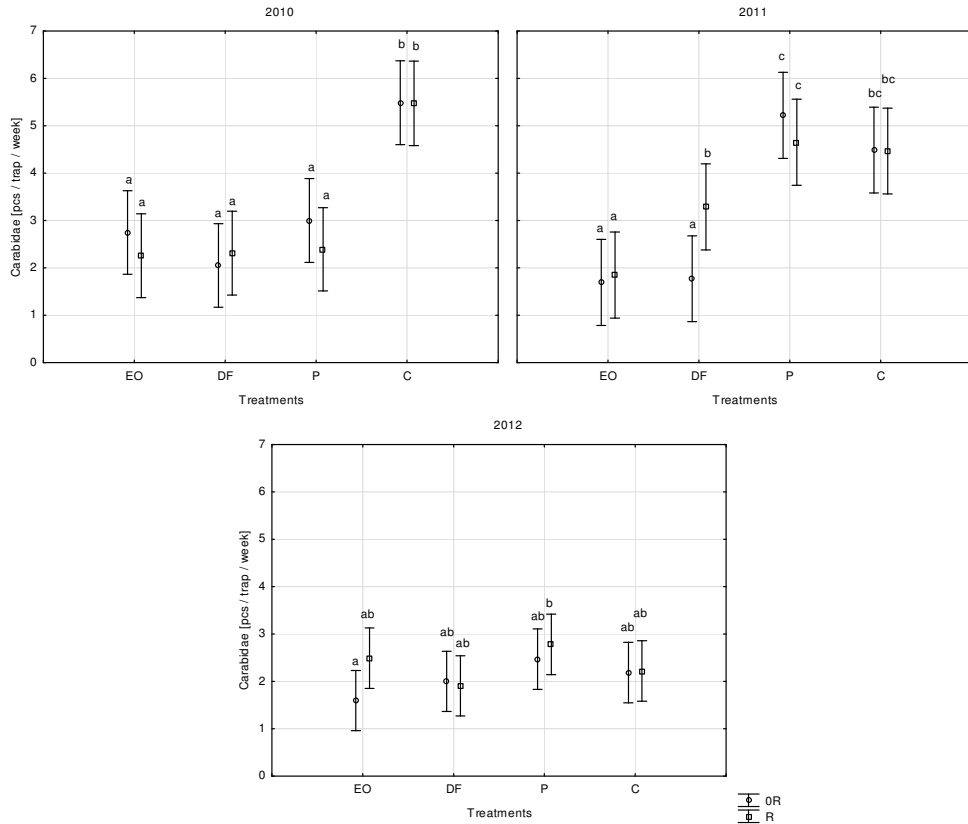

Fig. 4. Occurrence of Carabidae trapped using Barber's traps mean in the years 2010, 2011, 2012. The symbols as in Figure 1. Means marked with the same letters in a given year do not differ significantly according to LSD test at  $\alpha = 0.05$ ; factors contamination x remediation.  $\pm$  Mean  $\pm 0.95$  confidence interval

No influence of bioremediation process on Carabidae presence was observed for a most part of the period of investigations. Similarly, bioremediation did not affect the occurrence of a total of arachnid representatives trapped using Barber's traps, although a diversification within Arachnida orders was registered [8]. Bioremediation of soil polluted with petrol contributed to limited occurrence of Opiliones, especially during the first month after its completion, whereas a beneficial effect of this measure on the presence of terrestrial mites was noted in the third month after the soil contamination. Advantageous effect of bioremediation of soil polluted with petrol visible as increase in the number of captured insects already immediately after its beginning (0-5 months) was registered for Gastropoda representatives [14]. Like in case of Carabidae, during the period from 11 to 16 months after contamination, more snails were found in conditions of soil polluted with diesel fuel and subjected to remediation, than when this measure was not applied. In both cases it may result from a beneficial effect of bioremediation on overgrowing polluted soil with vegetation. Carabidae, like snails prefer shadowed sites, covered with vegetation. This



factor was mentioned as among others often conditioning greater activity of Carabidae when chemical plant protection is applied [15].

## Conclusions

1. Carabidae activity is to various extent limited in conditions of soil pollution with oil derivatives depending on the kind of applied substance. Petrol reveals negative effect for the shortest period of time (*ca* 3 months), whereas both diesel oil and engine oil act for a much longer period: diesel fuel may have a negative effect for 12 months, whereas engine oil for 15 months from the time of soil pollution.
2. The process of bioremediation of soil polluted with oil derivatives does not influence Carabidae activity during the first five months after its initiation, whereas in the later period (after a year) it may contribute to increased activity of Carabidae in conditions of soil polluted with diesel fuel, at the same time neutralizing the negative effect of the above-mentioned substance.

## Acknowledgement

Scientific publication financed from the funds for science in 2009-2012 as a research project (N N305 151537).

## References

- [1] Hartley W, Uffindell L, Plumb A, Rawlinson HA, Putwain P, Dickinson NM. Assessing biological indicators for remediated anthropogenic urban soils. *Sci Total Environ.* 2008;405(1-3):358-369. DOI: <http://dx.doi.org/10.1016/j.scitotenv.2008.06.004>.
- [2] Lock K, Desender K, Janssen CR. Effects of metal contamination on the activity and diversity of carabid beetles in an ancient Pb, Zn mining area at Plombières (Belgium). *Entomol Exp Appl.* 2001;99:355-360.
- [3] Ribera I, Dolédec S, Downie IS, Foster GN. Effect of land disturbance and stress on species traits of ground beetle assemblages. *Ecology.* 2001;82:1112-1129. DOI: [http://dx.doi.org/10.1890/0012-9658\(2001\)082\[1112:EOLDAS\]2.0.CO;2](http://dx.doi.org/10.1890/0012-9658(2001)082[1112:EOLDAS]2.0.CO;2).
- [4] Hedde M, van Oort F, Lamy I. Functional traits of soil invertebrates as indicators for exposure to soil disturbance. *Environ Pollut.* 2012;164:59-65. DOI:10.1016/j.envpol.2012.01.017.
- [5] Couceiro SRM, Hamada N, Ferreira RLM, Forsberg BR, da Silva JO. Domestic sewage and oil spills in streams: effects on edaphic invertebrates in flooded forest, Manaus, Amazonas, Brazil. *Water Air Soil Pollut.* 2007;180(1-4):249-259. DOI: 10.1007/s11270-006-9267-y.
- [6] Jaworska M, Gospodarek J. Occurrence of predatory Col. Carabidae beetles in conditions of soil polluted with oil derivatives. *Ecol Chem Eng A.* 2006;13(1-2):73-78.
- [7] Kołoczek H, Kaszycki P. Bioremediacja zanieczyszczeń rafineryjnych w środowisku gruntowo-wodnym. In: *Metody usuwania zanieczyszczeń węglowodorowych ze środowiska gruntowo-wodnego.* Rychlicki S, editor. Kraków: Wyd AGH; 2006.
- [8] Gospodarek J, Kołoczek H, Petryszak P. Dynamics of arachnid occurrence in soil contaminated with petrol, diesel fuel and engine oil during bioremediation process. *Ecol Chem Eng A.* 2012;19(9):1099-1106. DOI: 10.2428/ecea.2012.19(09)105.
- [9] Vandermeulen JH. Toxicity and sublethal effects of petroleum hydrocarbons in freshwater biota. Oil in freshwater. Chemistry, Biology, Countermeasure Technology. Proc of the Symposium of Oil Pollution in Freshwater, Edmonton, Alberta, Canada. Vandermeulen JH, Hrudey SE, editors. Canada: Pergamon Press; 1987.
- [10] Lee LEJ, Stassen J, McDonald A, Culshaw C, Venosa AD, Lee K. Snails as biomonitors of oil-spill and bioremediation strategies. *Bioremediation J.* 2002;6(4):373-386.
- [11] Stroomberg GJ, Zappy H, Steen RJCA, van Gestel CAM, Ariese F, Velthorst NH, van Straalen NM. PAH biotransformation in terrestrial invertebrates - a new phase II metabolite inisopods and springtails. *Comp Biochem Physiol.* 2004; C138:129-137.

- [12] Santos SAP, Cabanas JE, Pereira JA. Abundance and diversity of soil arthropods in olive grove ecosystem (Portugal): effect of pitfall trap type. *Eur J Soil Biol.* 2007;43:77-83.
- [13] Gospodarek J. Effect of oil derivative spill on epigeal invertebrates. *Ecol Chem Eng A.* 2009;16(3):263-270.
- [14] Gospodarek J, Kołoczek H. Wpływ zanieczyszczenia gleby substancjami ropopochodnymi na występowanie ślimaków (Gastropoda). *Polish J Agron.* 2012;11:10-14.
- [15] Sokołowski A. Ochrona upraw rolnych, a drapieżne stawonogi naziemne. *Post Ochr Roślin / Progr Plant Protect.* 2000;40(2):587-589.

## **ODDZIAŁYWANIE BIOREMEDIACJI GLEBY ZANIECZYSZCZONEJ ROPOPOCHODNYMI NA WYSTĘPOWANIE BIEGACZOWATYCH (COLEOPTERA, CARABIDAE)**

Katedra Ochrony Środowiska Rolniczego, Uniwersytet Rolniczy w Krakowie

**Abstrakt:** Celem pracy było zbadanie oddziaływania substancji ropopochodnych (benzyny, oleju napędowego, zużytego oleju silnikowego) w trakcie procesu bioremediacji gleby na przebieg dynamiki występowania biegaczowatych. Aktywność biegaczowatych w warunkach zanieczyszczenia gleby ropopochodnymi jest ograniczana w różnym stopniu zależnie od rodzaju użytej substancji. Benzyna wykazuje negatywny wpływ najkrócej (ok. 3 miesiące), znacznie dłużej oddziałują oleje - napędowy może wykazywać negatywny wpływ jeszcze po upływie 12 miesięcy, natomiast silnikowy po upływie 15 miesięcy od momentu zanieczyszczenia. Proces bioremediacji gleby zanieczyszczonej ropopochodnymi nie wpływa na aktywność biegaczowatych w ciągu pierwszych 5 miesięcy po jego zainicjowaniu, natomiast w późniejszym okresie (po upływie roku) może przyczyniać się do wzrostu aktywności Carabidae w warunkach gleby zanieczyszczonej olejem napędowym, niwelując tym samym negatywny wpływ wymienionej substancji.

**Słowa kluczowe:** ropopochodne, gleba, bioremediacja, Carabidae

Katarzyna GRATA<sup>1</sup> and Małgorzata NABRDALIK<sup>1</sup>

## ANTIFUNGAL ACTIVITY OF BACTERIAL SPECIES *Bacillus* AGAINST *Alternaria* sp.

### AKTYWNOŚĆ PRZECIWRZYBOWA BAKTERII Z RODZAJU *Bacillus* WOBEC *Alternaria* sp.

**Abstract:** The aim of the study was to assess the fungistatic activity of cell-free supernatants (CFS) obtained from 4, 6, 8, 10 and 24-hour culture of *Bacillus* KF2 and *Bacillus* BK2 against *Alternaria* sp. The antagonistic activity of bacterial exometabolites was determined by the dual-culture technique both on Czapek and PDA media. Plates were incubated at 28°C for 13 days and the fungal growth was measured every 2 days. The antagonistic activity of these strains was evaluated as the growth rate index. The growth of *Alternaria* sp. was 4-fold and 5-fold slower after application of CFS obtained from *Bacillus* KF2 (respectively on PDA and Czapek media) than in control. In case of 10-hour culture and 4-hour culture maximum antifungal activity of this strain was observed on PDA and Czapek media, respectively. This strain reduced the growth rate of *Alternaria* sp. from 72 to 80%. However, inhibition of *Alternaria* sp. by *Bacillus* BK2 was markedly less than that by *Bacillus* KF2. An increase in age of culture of *Bacillus* BK2 correspondent to an increase in the percent of inhibition up to 24-hour culture from 16% to 22% on PDA and Czapek media, respectively. Supernatants obtained from the culture of both strains showed fungistatic activity against *Alternaria* sp., depending on the age of the culture and the composition of the medium, although the *Bacillus* KF2 showed a stronger effect than *Bacillus* BK2. The experimental results exhibit the fungistatic activity of *Bacillus* strains and indicate the possibility of using theirs, especially *Bacillus* KF2, as antifungal agents against *Alternaria* sp.

**Keywords:** *Bacillus* sp., *Alternaria* sp., antifungal activity, growth rate index

### Introduction

Plant pathogens are the most important factors that cause major losses and damages to agricultural products every year. Phytopathogenic fungi affecting crop and post-harvested vegetables are major threat to food production and food storage. Moreover fungi are potential health hazard for humans due to the production by them toxic metabolites. Current agriculture is based largely on the application of synthetic pesticides and fungicides. The exercise use of agrochemicals lead to the emergence of pathogen resistance and serve negative impacts on the environment, cause serious effect to human health and non-target organisms. Therefore, it is a growing demand for new and safer methods to reduce, replace or at least supplement the existing control strategies. One of the most promising means to achieve this is the use of new tools based on *biological agents* (BCAs) for disease control [1-5].

In recent years, there has been a growing interest in potential use as plant protection non-pathogenic microorganisms isolated from natural environment as promising alternatives to synthetic chemicals. While diverse bacteria may contribute to the biological control of plant pathogens, most of the research and development efforts focused on two genera, *Bacillus* and *Pseudomonas*. *Bacillus* species posses several advantages that make them good candidates for use as BCAs. First, they produce several different (various) types

<sup>1</sup> Independent Chair of Biotechnology and Molecular Biology, University of Opole, ul. kard. B. Kominka 6a, 45-035 Opole, phone 77 401 60 56, email: kgrata@uni.opole.pl

of antimicrobial compounds, such as antibiotics, cell wall degrading enzymes and siderophores. Second, they induce growth and defence responses in the host. Furthermore, *Bacillus* sp. are able to produce spores that are resistant to UV light and desiccation, and that allow them to resist adverse environmental conditions and permit easy formulation for commercial purposes [1, 2, 5-7].

## Materials and methods

The involvement of antifungal compounds produced by the *Bacillus* strains KF2 and BK2 in the inhibition of fungal growth was confirmed by the ability of *cell-free culture* (CFS) filtrate of these strains to inhibit of hyphal growth of *Alternaria* sp. The *Bacillus* strains were inoculated into a flask containing the nutrient broth (OD (*Optical density*) = 2.0 at  $\lambda = 560$  nm) and incubated at 30°C for various times to give 4, 6, 8, 10 and 24-hour culture (working culture). The *Alternaria* sp. strain was cultivated on Czapek-Dox medium at 25°C for 5 days. The antagonistic activity of the tested *Bacillus* strains was evaluated as the rate index of fungal growth.

**Determination of influence of *Bacillus* strains on mycelium growth.** Fungal mycelial-disks (diameter of 10 mm) obtained from growing cultures of tested fungal isolates were placed in the centre of Czapek-Dox and PDA media that containing 0.5 cm<sup>3</sup> working cultures of *Bacillus* strains (in four replications). A control was made only with fungal mycelial-disks on both media without bacteria. After incubation at 27°C for 14 days, plates were observed at 2 days intervals and estimated as the rate *index of fungal growth* (*I<sub>fg</sub>*) using the formula [8]:

$$I_{fg} = \frac{A}{D} + \frac{b_1}{d_1} + \dots + \frac{b_x}{d_x}$$

where *A* is the mean from colony measurement, *D* is the experiment duration (days), *b<sub>1</sub>...b<sub>x</sub>* is the increase a colony diameter from lasted measurement, *d<sub>1</sub>...d<sub>x</sub>* is the number days from lasted measurement.

## Results and discussion

The antifungal activity of *Bacillus* KF2 and *Bacillus* BK2 strains grown on 2 different media was evaluated towards tested *Alternaria* sp. as the growth rate index. The results of the study showed that *Alternaria* sp. was sensitive to the metabolites produced by the tested strains from the genus *Bacillus* isolated from the natural environment. Fungistatic activity was determined by many factors, and depended mainly on the biological properties of these strains and their culture age, the growth media used and the susceptibility of the fungus. This might be due to secretion of metabolites secreted by these strains, diffused and dissolved into the culture media.

Promising results have been achieved particularly for *Bacillus* KF2. This strain was the most active on the Czapek medium, where the carbon source was sucrose (Fig. 1).

An antagonistic activity of *Bacillus* KF2 was most effective when the supernatant was obtained from 4 and 6-hour of cultures. The percentage decrease in the growth rate index was 80.9 and 80.7, respectively.

The results obtained for the other supernatants were also high and their impact on the growth of *Alternaria* sp. fluctuated in the 77-79 percent range. The lowest impact on the growth rate index had 24-hour bacterial culture. The value of the growth rate index amounted 0.98 and was almost 5-fold lower compared with the control test (Fig. 1).

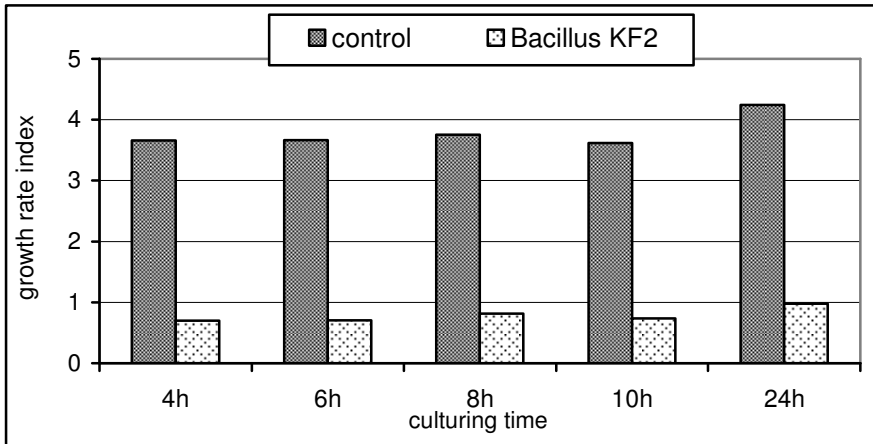

Fig. 1. Antifungal activity of *Bacillus* KF2 on Czapek medium against *Alternaria* sp.

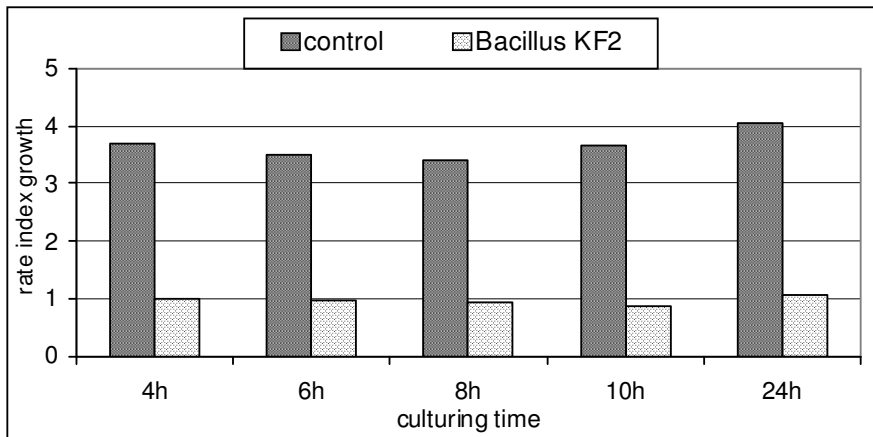

Fig. 2. Antifungal activity of *Bacillus* KF2 on PDA medium against *Alternaria* sp.

This strain proved to be equally efficient on the PDA medium as showed on Czapek medium limiting the linear growth of *Alternaria* sp. in the range from 72 to 76% when compared with the control. The most effective was the 10-hour culture whereas at least effective 8 hour culture of the *Bacillus* KF2 strain, where the index growth rate amounted 0.87 and 0.92, respectively (Fig. 2). On both media, the difference in the inhibitory action

of metabolites between the most and least acting culture of *Bacillus* KF2 amounted to slightly over 3.0%.

In presented study, fungistatic activity was also found for *Bacillus* BK2 against *Alternaria* sp. However, its effectiveness was significantly lower than that observed for strain *Bacillus* KF2. On PDA medium has been observed that with the raising the length of culturing time increased gradually fungistatic activity of this strain.

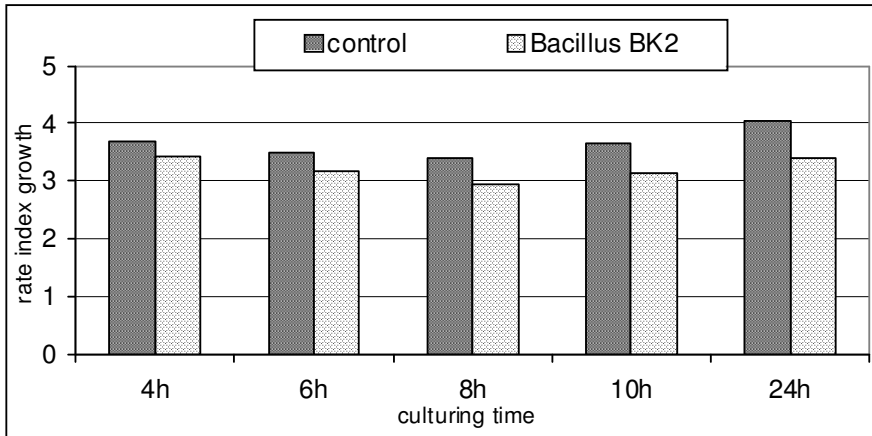

Fig. 3. Antifungal activity of *Bacillus* BK2 on PDA medium against *Alternaria* sp.

The decrease in the growth rate index was very low and amounted from 7.8 to 16.3% for the supernatants obtained from 4 and 6-hour culture, respectively. The linear growth of the mycelium was inhibited most actively when the medium was supplemented with 24-hour supernatant of *Bacillus* BK2 and amounted 3.40 compared with the control - 4.06 (Fig. 3).

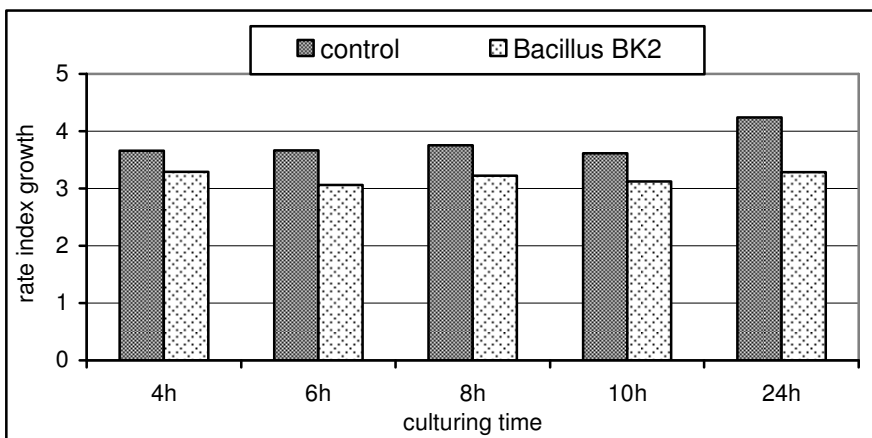

Fig. 4. Antifungal activity of *Bacillus* BK2 on Czapek medium against *Alternaria* sp.

Slightly higher activity of this strain was recorded on the Czapek-Dox medium. As the PDA medium, the growth rate inhibition of *Alternaria* sp. was the weakest when the supernatant of 4-hour culture of this strain was applied and amounted only 10%. However, 2-fold higher level of reduction in the growth rate was found for the supernatant obtained from the oldest namely 24 hour culture. The decrease of growth rate index achieved the value of 22.5% (Fig. 4).

On both media, the difference in the inhibitory action of metabolites between the youngest and oldest culture of *Bacillus* BK2 was 2-fold and amounted to about 10%. Although the growth of *Alternaria* sp. on the Czapek medium, both in the control and the test, was higher than on PDA medium, then the differences in the activity of these two strains were comparable.

### Conclusion

1. The inhibitory properties of *Bacillus* sp. strains were depended on the kind of the ones: the age of the bacterial culture and/or strains of *Bacillus*, the composition of the medium, duration of the experiment and the susceptibility of the fungus.
2. Supernatants obtained from the culture of both strains showed fungistatic activity against *Alternaria* sp., although the *Bacillus* KF2 showed a stronger effect than *Bacillus* BK2.
3. The growth of *Alternaria* sp. was strongly inhibited (from 72 to 81%) by *Bacillus* KF2 on both media, however by *Bacillus* BK2 to a lesser extent (from 7 to 22%).
4. The experimental results established the fungistatic activity of the tested *Bacillus* strains and indicate the possibility of using theirs, especially *Bacillus* KF2, as antifungal agents against *Alternaria* sp.

### References

- [1] Khokar MK, Gupta R, Sharma R. Scientific Reports. 2012;1(5):1-6. DOI: 10.4172/scientificreports.277.
- [2] Perez-Gracia A, Romero D, Zeriouh H, Vicente A. Biological control of phytopathogenic fungi by aerobic endospore-formers. In: Logan NA, Vos PDe. Endospore-forming Soil Bacteria. Soil Biology 27, Berlin Heidelberg: Springer; 2011:157-180. DOI: 10.1007/978-3-642-19577-8\_8.
- [3] Cal A, Larena I, Guijarro B, Melgarejo P. Agriculture. 2012;2:109-124. DOI: 10.3390/agriculture2020109.
- [4] Tomalak M. Progr in Plant Protect. 2010;50(3):1053-1063.
- [5] Recep K, Fikrettin S, Erkol D, Cafer E. Biological Control. 2009;50:194-198. DOI: 10.1016/j.biocontrol.2009.04.004.
- [6] Yadav S, Kaushik R, Saxena A, Arara K. J Basic Microbiol. 2011;51:98-106. DOI: 10.1002/jobm.201000098.
- [7] Jamalizadeh M, Etebarian HR, Aminian H, Alizadeh A. J of Plant Protect Res. 2009;49(4):403-410.
- [8] Burgiel Z. Acta Agrar et Silvestr Ser Agraria. 1984;23:187-199.

## AKTYWNOŚĆ PRZECIWGRZYBOWA BAKTERII Z RODZAJU *Bacillus* WOBEC *Alternaria* sp.

Samodzielna Katedra Biotechnologii i Biologii Molekularnej, Uniwersytet Opolski

**Abstrakt:** Celem podjętych badań była ocena aktywności fungistatycznej supernatantów otrzymanych z 4-, 6-, 8-, 10- i 24-godzinnych hodowli *Bacillus* KF2 i *Bacillus* BK2 wobec *Alternaria* sp. Na podstawie indeksu tempa wzrostu określono aktywność fungistatyczną szczepów *Bacillus* sp. na podłożach PDA i Czapka. Wyniki badań

wskazują, że tempo wzrostu *Alternaria* sp. na tych podłożach było 4-krotnie oraz 5-krotnie wolniejsze po zastosowaniu supernatantów uzyskanych z hodowli *Bacillus* KF2 niż w próbce kontrolnej. Maksymalną aktywność tego szczepu zanotowano po zastosowaniu 10-godzinnej i 4-godzinnej hodowli odpowiednio na podłożach PDA i Czapka. Natomiast aktywność przeciwgrzybowa szczepu *Bacillus* BK2 była znacznie mniejsza niż *Bacillus* KF2. Wraz ze wzrostem wieku hodowli *Bacillus* BK2 do 24 h obserwowano wzrost hamowania tempa wzrostu na obu podłożach (od 16 do 22%). Supernatanty otrzymane z hodowli obu szczepów wykazały działanie fungistatyczne wobec *Alternaria* sp., przy czym silniejszy wpływ wykazał *Bacillus* KF2, redukując tempo wzrostu o ok. 70-80% w zależności od wieku hodowli. Uzyskane wyniki badań potwierdzają aktywność fungistatyczną szczepów *Bacillus* sp. i wskazują na możliwość wykorzystania ich, szczególnie szczepu *Bacillus* KF2, jako środków przeciwgrzybiczych wobec *Alternaria* sp.

**Słowa kluczowe:** *Bacillus* sp., *Alternaria* sp., aktywność fungistatyczna, indeks tempa wzrostu



Anna IŻEWSKA<sup>1</sup>, Justyna CHUDECKA<sup>2</sup>, Tomasz TOMASZEWICZ<sup>2</sup>  
and Mariola WRÓBEL<sup>3</sup>

## CONTENT OF ELEMENTS IN SOILS OF ROADSIDES' AND CHARACTERISTIC OF PLANT SPECIES SETTLED

### ZAWARTOŚĆ PIERWIASTKÓW W GLEBACH POBOCZA DRÓG ORAZ CHARAKTERYSTYKA GATUNKÓW ROŚLIN JE ZASIEDLAJĄCYCH

**Abstract:** The paper presents research results concerning the content of micro- and macroelements in soils of roadsides and spatial distribution of roadside flora on the basis of trophic index. Shoulder area with width of 5 m was studied, along roads with hardened surface going through agricultural lands in Szczecin Lowlands. The content of forms regarded assimilable macroelements (phosphorus, potassium, magnesium) in zone soils - the edge of the shoulder and proper shoulder - was different from the zone soils - ditch and slope. Soil richness in assimilable phosphorus was low in all researched areas, potassium was high in A and B zones, medium in C and D zones, and magnesium on the edge of shoulder and proper shoulder was medium, and low in the ditch and embankment. Assessing soil richness in microelements (with the exception of iron), it was found that it was in the same class in the researched shoulder areas: manganese - medium, zinc - high, copper - high (A, B, C zones). Calculated rates of soil salinity (Z, SAR) show no signs of salinity and present good conditions for plant growth. Analysis of the trophic index showed domination of species preferring eutrophic soil (Tr = 4) and extremely eutrophic (Tr = 5) throughout the whole profile of vertical formation of roadsides in the mid-field on the researched area.

**Keywords:** roadside soils, content of macro- and microelements in soil, roadside flora

### Introduction

The use of salt during winter exploitation of roads is a factor influencing soil properties. Snow-clearing of routes can lead to soil salinity and greenery eradication along them [1]. The strength of their impact is associated with both substrate material properties as well as the distance from the roadway. Chemicals used for snow removal are chemical compounds that cause melting of ice according to Kolodziejczyk [2] the most commonly used are pure sodium chloride (NaCl), road salt which is a mixture of sodium chloride (NaCl) - 97%, calcium chloride (CaCl<sub>2</sub>) - 2.5% and hexacyanoferrate(II), potassium (K<sub>4</sub>Fe(CN<sub>6</sub>)) - 0.5%, saline - sodium chloride (NaCl) or calcium chloride (CaCl<sub>2</sub>) at a concentration of 20-25%, technical calcium chloride (77-80% CaCl<sub>2</sub>), pure magnesium chloride (MgCl<sub>2</sub>), and a mixture of sodium chloride (NaCl) with calcium chloride (CaCl<sub>2</sub>) or magnesium chloride (MgCl<sub>2</sub>).

The aim of this paper is to access changes in content and richness category of forms acknowledged as assimilable macro- and microcomponents in roadside soil along agricultural areas in Szczecin Lowlands and participation of plant species with different trophic index.

<sup>1</sup> Department of Sanitary Engineering, West Pomeranian Technological University, al. Piastów 50, 70-311 Szczecin, email: anna.izewska@zut.edu.pl

<sup>2</sup> Department of Soil Reclamation and Environmental Chemistry, West Pomeranian Technological University, ul. J. Słowackiego 17, 71-434 Szczecin

<sup>3</sup> Department of Botany and Nature Protection, West Pomeranian Technological University, ul. J. Słowackiego 17, 71-434 Szczecin, email: mariola.wrobel@zut.edu.pl

## Material and methods

In Spring 2005, research was carried out in order to study roadsides with hardened surface (asphalt) and with comparable capacity, located along agricultural areas of Szczecin Lowlands.

For the purpose of observation there were chosen four sample collection points located outside build-up areas along forest roads (mid-field): Kolbacz 53°18'17"N, 014°48'00"E; Zabow 53°07'26"N, 014°47'14"E; Kunowo 53°20'28"N, 014°56'21"E; Kobylanka 53°20'07"N, 014°51'41"E.

Sampling from the top layer of humus 0-10 cm of roadside was performed in spring (March) in each sample collection point. Four characteristic roadside zones were researched, situated as follows:

- A - road shoulder edge adjoining the road surface (0.2-0.3 m width),
- B - proper road shoulder (1.0-1.2 m width),
- C - ditch (1.0-1.5 m width, 0.5-0.8 m depth),
- D - slope (1.0-2.5 m height, inclination 30°) [3].

Using methods generally accepted in soil science, determinations were done as follows: granulation, soil pH reaction measured in KCl solution of 1 mol · dm<sup>-3</sup> (pH<sub>KCl</sub>) concentration and loss on ignition at 550°C. Content of forms regarded as available to plants, after extraction with HCl at a concentration of 0.5 mol · dm<sup>-3</sup> [4], was determined by AAS: K, Ca Mg, Na, Cu, Fe, Mn, Zn, and P colorimetrically.

Soil salinity was calculated on the basis of degree of changes in soil sodium (Z) relative to the amount of sodium ions of calcium and magnesium ions expressed in equivalent amounts [5], and SAR (*Sodium Adsorption Ratio*) [6]:

$$Z = \frac{\text{Na}}{\text{Ca} + \text{Mg}}$$

$$\text{SAR} = \frac{\text{Na}}{\sqrt{\frac{\text{Ca} + \text{Mg}}{2}}}$$

The significance of differences in element content between zones was determined by using Tukey's HSD test, while the LSD value at 0.05 significance level test of Newman-Keulus, using the program Statistica 9.

The assessment of soil was carried out according to the classification of Sapek and Sapek [4], which is applied to agricultural grasslands. Because the tested samples contained less than 20% of organic matter, classification of the nutrient content was made, which divided soil richness into three grades: low, medium and high. The exception was magnesium, which content was valued for five grades of abundance.

## Results and discussion

Data included in Table 1, characterizing researched soil, were already presented in earlier publications [3, 7]. Re-presentation was necessary to assess soil fertility.

Granulation of researched objects was even, in first zone was sand, and the rest loamy sand according to PTG classification [8], pH<sub>KCl</sub> values allowed to determine that in A and B zones the reaction was neutral.

Salinity as well content of organic carbon were decreasing as the distance from the edge of the road was further revealing high negative correlation [3].

Table 1

The mean value of chosen properties in the 0-10 cm layer of mid-field sideroads

Roadside zone	Corg. [%]	pH <sub>KCl</sub>	Salinity [g NaCl · kg <sup>-1</sup> of soil]	Percentage content of fractions with diameter [mm]			
				> 2	2-0.5	0.5-0.002	< 0.002
A	4.23	7.22	0.739	13.5	86.4	10.6	2.9
B	2.49	7.16	0.503	4.7	83.3	13.4	3.3
C	1.62	6.89	0.238	2.2	79.4	15.7	4.9
D	1.62	6.66	0.210	2.3	79.2	17.1	3.7

The content of phosphorus extracted from soil of 0.5 mol · dm<sup>-3</sup> HCl from soil was significantly greatest at the edge of the road shoulder (4.68 mg · 100 g<sup>-1</sup> of soil). The further from the roadway, the content of this element was decreasing. In the second area there was about 30.6, about 53.0 in the third and in the fourth 62.4% less phosphorus in comparison with the first zone (Table 2).

Table 2

The average content of macro- and microelements soluble in 0.5 mol · dm<sup>-3</sup> HCl in 0-10 cm layer of soil from the roadsides and homogenous groups

Shoulder zone	Chemical elements									Soil salinity indicator	
	P	K	Mg	Ca	Na	Cu	log Fe	Mn	Zn	Z	SAR (Sodium Adsorption Ratio)
	[mg · 100 g <sup>-1</sup> of soil]					[mg · kg <sup>-1</sup> of soil]					
A	4.68 a	51.2 a	79.0 a	5.98 a	0.975 a	36.5	1.45 a	164.7	76.4	0.0115	0.053
B	3.25 ab	41.7 ab	51.3 ab	6.21 a	0.555 b	15.6	1.28 ab	128.2	104.5	0.0096	0.036
C	2.20 b	26.3 b	33.9 ab	3.27 ab	0.175 c	10.3	1.24 ab	132.1	61.3	0.0047	0.014
D	1.76 b	22.7 b	27.7 b	2.67 b	0.099 c	5.4	1.14 b	181.4	50.8	0.033	0.0090
LSD <sub>0.05</sub>	1.52	20.9	49.2	3.07	0.249	n.i.	-	n.i.	n.i.	-	-

Indeed, in roadside ditch there was the least abundance of phosphorus comparing with the edge of shoulder. However, abundance in all those areas was low. The content of phosphorus soluble in 0.5 mol · dm<sup>-3</sup> HCl in muck soils for the surface layer amounted from 36.6 to 44.5 mg · 100 g<sup>-1</sup> of soil [9]. In the assessment of abundance by Sapek and Sapek [3] in muck peat soil and proper muck soil high content of soluble phosphorus assimilable for plants was stated. This is due to the large share of iron complexed with humic compounds, which reduces its sorption ability toward phosphorus. Valuing the content of potassium it was established that in A and B zones it was high, and in two others it became medium. Indeed, most potassium was in zone A, in comparison with C and D zones. In studies conducted by Kochanowska and Kusza [10] content of potassium in water extract from urban soils prone to salinity ranged from 0.78 to 5.16 mg K · 100 g<sup>-1</sup> of soil. The amount of magnesium in soil was decreasing as the distance from the road was further, significant difference of its content was found only between the soils at the edge of the shoulder and soil on the slope (Table 2). Together with changes in magnesium content there

were changes in abundance, in the first two zones it was medium, while in the remaining it was low. The content of calcium ranged from  $2.67 \text{ mg} \cdot 100 \text{ g}^{-1}$  of soil (slope) to  $6.21 \text{ mg} \cdot 100 \text{ g}^{-1}$  of soil (the edge of the shoulder). Significant differences were found between zones A, B and D. The content of sodium was the smallest and most diverse. Considerable differences occurred between the soils at the edge of the shoulders, the proper shoulders and soils of zones C and D, which form a homogeneous group.

In the case of differences of microelements in the content of forms available to plants, they were found only for iron. The decrease in iron content occurred as the distance from the road was further and it caused a significant difference between A and D zones. In analysis of the other microelements no important dissimilarities were found. Abundance was developing as follows: copper from the first zone to the third was high, for the fourth zone it was medium, manganese for all the researched zones was medium, and high for zinc.

Soil salinity indicators *Z* and *SAR* are not equivalent. Both allow for assessment of environmental risks associated with soil environment connected to content of soluble salts of sodium [5]. In the study, the rate was less than 1 which indicates no signs of salinity. Moreover, the *SAR* ratio was less than 10, so there are normal conditions for the development of plants in the soil (Table 2). It was observed that the further from the roadway, the lower was the value of indexes researched.

Rating the number of species observed on the edge of the road shoulder (A), on the proper road shoulder (B), in ditches (C), and on slopes (D) showed a similar number of species found in roadside ditches and on slopes (on average 19 taxons).

In further zones of the road shoulder, which were situated next to road surface, the most species were recorded on the roadside slope (on average 15 taxons), proper shoulder (on average 14 taxons) and the edge of the shoulder (on average 8 taxons). Analysis of trophism index based on ecological index numbers [11] showed a definite domination of species preferring eutrophic soils ( $Tr = 4$ ) and extremely eutrophic ( $Tr = 5$ ) throughout the whole profile of vertical formation of mid-field roadsides in the researched area. The edge of the shoulder marked out itself with the highest presence of taxons preferring eutrophic soils and extremely eutrophic, including more than 70% of all observed species. Among them the most frequently noted were as follows: *Plantago major*, *Lolium perenne*, *Poa annua*, *Chamomilla suaveolens*, *Trifolium repens* and *Chenopodium album* (Fig. 1).

In the following shoulder zones participation of species associated with eutrophic soils and extremely over-fertilised was gradually diminishing. On the proper shoulder of mid-field roads they accounted for about 56% of all recorded species, and the most frequently observed taxons were as follows: *Daucus carota*, *Dactylis glomerata*, *Arrhenatherum elatius*, *Ranunculus repens*, *Leontodon autumnalis*, *Lamium purpureum*, *Trifolium pratense* and *Glechoma hederacea*. In roadside ditches and on roadside slopes of mid-field roads in the reasearch area, participation of such species reached 46% and 44%. The most frequently observed plants here were as follows: *Urtica urens*, *Melandrium album*, *Anthriscus sylvestris*, *Galium aparine*, *Artemisia sylvestris*, *Solidago gigantea*, *Epilobium hirsutum*, *Arctium tomentosum*, *Rumex crispus* or *Alopecurus pratensis*.

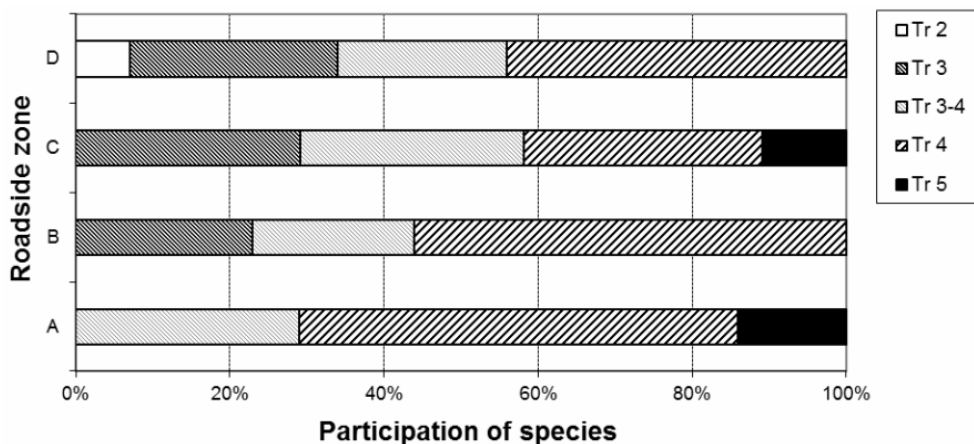

Fig. 1. The percentage of species at different trophic index by Zarzycki et al [11], in particular zones of mid-field roadsides. Key: A - edge of shoulder; B - proper shoulder; C - roadside ditch; D - roadside slope; Tr 1 - extremely oligotrophic soils; Tr 2 - oligotrophic soils; Tr 3 - mesotrophic soils; Tr 3-4 - meso- to eutrophic soils; Tr 4 - eutrophic soils; Tr 5 - extremely eutrophic soils

## Conclusions

1. The content of forms regarded assimilable macroelements - phosphorus, potassium and magnesium in soils of roadsides and proper roadside edges, was higher than in ditches and embankments, which were more distant from the road. Soil richness in assimilable phosphorus was low in all researched zones, high in potassium in A and B zones, medium in C and D zones, as it comes to magnesium it was medium on the edge of shoulder and proper shoulder, and low in the ditch and embankment.
2. Assessing the content of microelements in the soil, we can conclude that there were no significant differences between soils of each zone. The exception was the iron, where there was an important dissimilarity in its content between the edge of the shoulder and slope. Abundance of manganese, zinc and copper located itself in all areas of shoulders in the same class, medium for manganese, high for zinc and copper (A-C zones).
3. Calculated rates of soil salinity (Z, SAR) show no signs of salinity and present good conditions for plant growth.
4. Analysis of the trophic index showed domination of species preferring eutrophic soil (Tr = 4) and extremely eutrophic (Tr = 5) regardless of the distance from the roadway.

## References

- [1] Czerniawska-Kusza I, Kusza G, Dużyński M. Effect of deicing salt on urban soils and health status of roadside trees in the Opole Region. *Environ Toxicol.* 2004;19:296-301.
- [2] Kołodziejczyk U. Wpływ chlorku sodu stosowanego w zimowym utrzymaniu dróg na kapilarność gruntów. *UAM, Geologos.* 2007;11:218-226.
- [3] Wróbel M, Tomaszewicz T, Chudecka J. Floristic diversity and spatial distribution of roadside halophytes along forest and field roads in Szczecin lowland (west Poland). *Pol J Ecol.* 2006;54(2):303-309.
- [4] Sapek A, Sapek B. Metody analiz chemicznych gleb organicznych. *Falenty: Mat Instr IMUZ;* 1997:81.
- [5] Gołda T. *Rekultywacja.* Kraków: Uczel Wyd Nauk-Dydak. AGH; 2005.

- [6] Treder W. Jakość wody do nawadniania i filtrowania. *Szkółkarstwo*. 2004;5. <http://www.szkołkarstwo.pl/article.php?id=617>, online.
- [7] Chudecka J, Tomaszewicz T, Pacewicz K, Wróbel M. Wybrane właściwości chemiczne powierzchniowej warstwy gruntów przydrożnych w okresie wiosny i jesieni. *Folia Pomer Univ Technol Stetin*. 2010;14:49-56.
- [8] PTG 2008: [www.ptg.sggw.pl/images/Uziarnienie\\_PTG\\_2008.pgf.pdf](http://www.ptg.sggw.pl/images/Uziarnienie_PTG_2008.pgf.pdf), on line.
- [9] Bieniek B, Karwowska J, Bieniek A. Właściwości chemiczne ekstensywnie użytkowanych gleb murszowych na torfowisku "Siódmak". *Rocz Glebozn*. 2007;57(½):12-23.
- [10] Kochanowska K, Kusza G. Wpływ zasolenia na właściwości fizyko-chemiczne gleb Opola w latach 1994 i 2009. *Inż Ekol*. 2010;23:14-21.
- [11] Zarzycki K, Trzcińska-Tacik H, Różański W, Szeląg Z, Wołek J, Korzeniak U. *Ekologiczne liczby wskaźnikowe roślin naczyniowych Polski*. Kraków: Instytut Botaniki PAN; 2003.

## ZAWARTOŚĆ PIERWIASTKÓW W GLEBACH POBOCZA DRÓG ORAZ CHARAKTERYSTYKA GATUNKÓW ROŚLIN JE ZASIEDLAJĄCYCH

Katedra Inżynierii Sanitarnej, Zachodniopomorski Uniwersytet Technologiczny w Szczecinie

**Abstrakt:** Przedstawiono wyniki badań dotyczące zawartości makro- i mikroskładników w glebach poboczy dróg i przestrzennego rozmieszczenia flory przydrożnej na podstawie wskaźnika trofizmu. Badaniami objęto strefy pobocza o łącznej szerokości 5 m, wzdłuż dróg o nawierzchni utwardzonej przebiegającej przez tereny rolnicze na Nizinie Szczecińskiej. Zawartości form uznanych za przyswajalne makroskładniki (fosfor, potas, magnez) w glebach strefy skraj pobocza i pobocze właściwe różniła się od gleb stref rów i skarpa. Zasobność gleby w przyswajalny fosfor była niska we wszystkich badanych strefach, potasu wysoka w strefie A i B, a średnia w C i D, zaś magnezu średnia na skraju pobocza i poboczu właściwym, a niska w rowie i skarpie. Oceniając zasobność gleby w mikroskładniki (z wyjątkiem żelaza), stwierdzono, że była w tej samej klasie w badanych strefach pobocza: mangan - średnia, cynk - wysoka, miedź - wysoka (strefa A, B, C). Obliczone wskaźniki zasolenia gleby (Z i SAR) wskazują na brak oznak zasolenia i dobre warunki do wzrostu roślin. Analiza wskaźnika trofizmu wykazała zdecydowaną przewagę gatunków preferujących gleby eutroficzne (Tr = 4) i skrajnie eutroficzne (Tr = 5) w całym profilu pionowego ukształtowania pobocza dróg śródpolnych na badanym terenie.

**Słowa kluczowe:** gleby przydrożne, zawartość makro- i mikroskładników w glebie, flora przydrożna

Agnieszka JAGODA<sup>1</sup>, Witold ŻUKOWSKI<sup>1</sup> and Barbara DĄBROWSKA<sup>2</sup>

## PRESENCE OF CAFFEINE IN THE RUDAWA RIVER AND ITS TRIBUTARIES

### ZAWARTOŚĆ KOFEINY W RZECIE RUDAWIE I JEJ DOPŁYWACH

**Abstract:** 1,3,7-trimethylxanthine (caffeine) is an ingredient of coffee, tea, energy drinks, drugs and cosmetics. Generally, it is the most consumed pharmaceutical substance all over the world. Although it is easily metabolized, caffeine is present in wastewaters generated by households. Therefore, its detection in streams and rivers shows that untreated wastewaters are discharged into environment. Determination of caffeine in waterways could be an indicator of their anthropogenic pollution. Rudawa is the river flowing through southern Poland, with the river basin area about 318 km<sup>2</sup>. It is a left tributary of the Vistula River, with the river mouth located in the Krakow city. Rudawa is one of the drinking water supplies for the city. It provides about 40000 m<sup>3</sup> of water per year. Water used as a source of drinking water must be the highest quality. Therefore the river on which drinking water intakes are located is the subject of the special monitoring. Water quality monitoring has always been important on Rudawa river and it continues to be monitored today. The aim of this study has been to check whether the caffeine is present in Rudawa waters, to determine its concentration and localization of potential sources of pollution. Samples taken from the river in twelve selected locations along the Rudawa River and its tributaries have been analyzed. Solid phase extraction combined with gas chromatography-mass spectrometry (GC-MS) has been used. Caffeine isotope 13-C3 in methanol, Sigma Aldrich, has been used as an internal standard. The concentration of caffeine in samples has ranged from 40 to 380 ng/dm<sup>3</sup>.

**Keywords:** watercourse, caffeine, water pollution

### Introduction

1,3,7-trimethylxanthine (caffeine) is an ingredient of coffee, tea, energy drinks, drugs and cosmetics. Generally, it is the most consumed pharmaceutical substance all over the world. Although it is easily metabolized, caffeine is present in wastewaters generated by households. Therefore, its detection in streams and rivers shows that untreated wastewaters are discharged into environment. Determination of caffeine in waterways could be an indicator of their anthropogenic pollution [1, 2].

Rudawa is the river flowing through southern Poland, with a river basin area about 318 km<sup>2</sup>. It is the left tributary of the Vistula River, with the river mouth located in the Krakow city. Rudawa is one of the drinking water supplies for the city. It provides about 40000 m<sup>3</sup> of water per year [3].

Water used as a source of drinking water must be the highest quality. Therefore the river on which drinking water intakes are located is the subject of the special monitoring. Water quality monitoring has always been important on Rudawa River and it continues to be monitored today. The aim of this study has been to check whether the caffeine is present in Rudawa waters, to determine its concentration and localization of potential sources of pollution. The aim of this study has been to check whether the caffeine is present in

<sup>1</sup> Faculty of Chemical Engineering and Technology, Krakow University of Technology, ul. Warszawska 24, 31-155 Kraków, phone 12 628 27 67, email: ajagoda@chemia.pk.edu.pl , pczukows@pk.edu.pl

<sup>2</sup> Faculty of Environmental Engineering, Krakow University of Technology, ul. Warszawska 24, 31-155 Kraków, email: bdabrowska@vistula.wis.pk.edu.pl

Rudawa waters, to determine its concentration and localization of potential sources of pollution.

## Experimental

Water from the Rudawa River basin was analyzed. The coordinates and description of the sampling points can be found in Table 1 and on Figure 1. Samples were gathered at 26 June 2011. On the day the samples were collected temperature was around 20°C. There was no rain, but the day was cloudy, the sun started shining only at the afternoon. 2.7 dm<sup>3</sup> amber glass bottles were used to contain the samples.

Table 1

Water sampling spots

Creek	Sampling spot	Geographic coordinates	
		Latitude	Longitude
Krzeszowka	P1	50° 8'28.63"N	19°37'59.67"E
Filipowka	P2	50° 7'53.30"N	19°37'7.65"E
Dulowka	P3	50° 7'40.05"N	19°37'10.20"E
Krzeszowka	P4	50° 7'28.47"N	19°40'56.17"E
Rudawka	P5	50° 7'21.39"N	19°42'30.91"E
Bedkowka	P6	50° 8'19.74"N	19°44'42.11"E
Kobylanka	P7	50° 7'50.57"N	19°47'42.57"E
Kluczowoda	P8	50° 7'17.63"N	19°49'22.85"E
Rudawa	P9	50° 6'49.54"N	19°43'57.80"E
Rudawa	P10	50° 6'31.93"N	19°49'3.16"E
Rudawa	P11	50° 5'11.86"N	19°48'59.44"E
Rudawa	P12	50° 3'10.25"N	19°54'56.55"E

As soon as the samples were transported to the laboratory an internal standard (Caffeine isotope 13C3 in methanol, Sigma Aldrich) was added to the sample and the samples were put to the refrigerator. During the next few days samples were taken out and warmed to room temperature. The solutions' pH was elevated to 9 pH by adding a concentrated solution of sodium hydroxide (POCH). The solution was divided into three parts proportionally. Solid phase extraction was done by a VISIPRED 24TM DL (Supelco) set with 6 cm<sup>3</sup> cartridges containing 500 mg of C18 sorbent (J.T. Baker). The mixture of solvents ethyl acetate: acetone 1:1 (v/v) (POCH) was used as an eluent. The samples were concentrated in a vacuum concentrator (Concentrator 5301, Eppendorf) until the solvent was completely evaporated. Afterwards methanol (POCH) was added and methanol solutions were analyzed using gas chromatography and mass spectroscopy.

The GC/MS analyses were carried out on a Clarus 500 gas chromatograph (PerkinElmer)/ Clarus 500 mass spectrometer (PerkinElmer). A 30 m x 0.25 mm ID x 0.25 µm film Rtx®-200MS fused silica capillary column (Restek) was used. The GC oven temperature was programmed as follows: initial temperature of 70°C was held for 120 s, and then raised at 0.2°C/s to 250°C with a hold time for 120 s. The 1 mm<sup>3</sup> injection volume was carried out in a splitless mode at temperature of 250°C. The carrier gas was helium at a flow of 0.025 cm<sup>3</sup>/s. The mass spectrometer was working in:





Recovery of the internal standard for a single trial ranged between 35 and 170% and average recovery for all trials was 98%. The value of the average recovery of internal standard above one hundred percent could be caused at the stage of re-dissolution samples in methanol. Methanol can partly evaporate during dissolution of sludge because it is very volatile and thus concentrate samples. Maximum relative standard deviation is about sixteen percent shows the good precision of developed method.

Table 2

Caffeine concentration in water samples

Sampling spot	Number of samples	Average recovery of standard [%]	Caffeine concentration in water samples [ng/dm <sup>3</sup> ]	Relative standard deviation [%]
P1	3	118	380.1	9.0
P2	2	108	306.4	7.6
P3	3	106	163.2	8.2
P4	3	110	271.7	4.6
P5	3	66	67.5	8.9
P6	3	79	40.1	16.4
P7	3	45	116.1	16.1
P8	3	52	114.2	1.4
P9	3	83	180.4	10.8
P10	3	106	273.6	2.3
P11	3	116	288.2	3.7
P12	3	147	202.4	5.7

## Conclusions

The determination of caffeine concentration in creeks of the Rudawa River basin was done. Caffeine is an anthropogenic waste and its presence in the surface water confirms that untreated sewage is discharged into watercourses. This is unsafe because water from Rudawa is used as source of drinking water. The water samples were collected only once at the measuring points. It is necessary to repeat the analysis in the future. This will eliminate the influence of weather conditions.

## References

- [1] Jagoda A, Dąbrowska B, Żukowski W. Kofeina jako wskaźnik antropogenicznego zanieczyszczenia środowiska - metody oznaczania. V Krakowska Konferencja Młodych Uczonych. Kraków; 2010:255-263.
- [2] Jagoda A, Żukowski W, Dąbrowska B. Kofeina w rzekach Krakowa. Czasopismo Techniczne Politechniki Krakowskiej z. 6. Seria Środowisko z. 2. 2011: 99-108.
- [3] Wierzbicki R. Wodociągi Krakowa 1940-2000. Kraków: MPWiK S.A.; 2001.

## ZAWARTOŚĆ KOFEINY W RZECE RUDAWIE I JEJ DOPŁYWACH

<sup>1</sup> Wydział Inżynierii i Technologii Chemicznej, Politechnika Krakowska

<sup>2</sup> Wydział Inżynierii Środowiska, Politechnika Krakowska

**Abstrakt:** 1,3,7-trimetyloksantyna (kofeina) jest składnikiem kawy, herbaty, napoi energetyzujących, leków i kosmetyków. Jest najpowszechniej spożywanym farmaceutykiem na całym świecie. Choć jest łatwo metabolizowana, kofeina jest obecna w ściekach powstających w gospodarstwach domowych. Wykrycie kofeiny w wodach powierzchniowych dowodzi, że ścieki są bez oczyszczenia odprowadzane do środowiska. Oznaczenie zawartości kofeiny w ciekach może być uznane za wskaźnik ich antropogenicznego zanieczyszczenia. Rudawa to rzeka płynąca w południowej Polsce o powierzchni zlewni około 318 km<sup>2</sup>, jest lewostronnym dopływem Wisły, do której uchodzi na terenie miasta Krakowa. Rudawa jest jednym ze źródeł zaopatrzenia mieszkańców miasta w wodę. Dostarcza około 40 000 m<sup>3</sup> wody rocznie. Woda wykorzystywana jako źródło wody pitnej powinna być najwyższej jakości. Dlatego jakość wody rzeki, na której zlokalizowane jest ujęcie wody pitnej, powinna być pod szczególnym nadzorem. Monitorowanie jakości wody z rzeki Rudawy zawsze było prowadzone i jest nadal. Celem badania było sprawdzenie, czy kofeina występuje w wodach Rudawy, określenie jej stężenia i lokalizacji potencjalnych źródeł zanieczyszczeń. Pobrano dwanaście próbek wody z Rudawy i jej dopływów oraz przeprowadzono ich analizy metodą ekstrakcji do fazy stałej połączonej z chromatografią gazową ze spektrometrią mas (GC-MS). Zastosowano izotop <sup>13</sup>C-3 kofeiny w metanolu (Sigma Aldrich) jako wzorzec wewnętrzny. Stężenie kofeiny w próbkach wahało się od 40 do 380 ng/dm<sup>3</sup>.

**Słowa kluczowe:** ciek, kofeina, zanieczyszczenie wody



Anna JANICKA<sup>1</sup>

## IN-VEHICLE TOXICITY MEASUREMENTS: IN-VITRO TESTS AS A NEW METHOD OF TOXICOLOGICAL ESTIMATION OF CAR CABIN ATMOSPHERE

### TOKSYCZNOŚĆ WNĘTRZA POJAZDU: TESTY IN VITRO JAKO NOWA METODA OCENY TOKSYKOLOGICZNEJ POWIETRZA WEWNĄTRZ KABINY POJAZDU

**Abstract:** In the article the difficult problem of mixtures toxicity has been discussed. The problem is very important in aspect of human life environment especially indoor air quality. A vehicle interior is a specific environment where levels of volatile toxic organic compounds are particularly high. The method of gaseous mixtures toxicity estimation based on in-vitro tests has been presented in application for vehicle cabin interior and compare with the popular toxicity indicators (relative toxicity coefficients). The results of the method application in brand new passenger vehicles (in parking conditions) are presented. The results were correlated with volatile organic compounds concentration in vehicles interior (method: gas chromatography).

**Keywords:** vehicle interior, volatile organic compounds, indoor measurements, toxicity

#### Introduction

Vehicle cabin contributes specific environment of human existence where the level of *volatile organic compounds* (VOCs) concentration in air can be even few times higher than outside [1, 2]. The main exposure route of those substances is inhalation, which accounts for 99% of the total exposure of the general population. The health effects of toxic volatile compounds are well documented: acute (short-term) inhalation exposure of humans to benzene may cause drowsiness, dizziness, headaches, as well as eye, skin, and respiratory tract irritation, and, at high levels, unconsciousness. Chronic (long-term) inhalation exposure has caused various disorders in the blood, including reduced numbers of red blood cells, aplastic anemia, and even leukemia [1].

The methods of investigation of substance toxic activity can be general divided on [2]:

- estimation of substance toxicity based on relation between chemical structure of substance and its biological activity (new direction of toxicology science),
- investigation of substance toxicity based on tests on animals (the most popular method),
- alternative methods based on rule 3R (replacement, reduction, refinement) which aim is to eliminate or reduce of animal suffer.

For toxicity estimation and analysis of the group of substances usually data for one representative and common compound occurring in environment are used (*ie* benzene for VOCs group). The intensity of mutagenic, carcinogenic, irritant or sensitize activity of other compounds from the group is counted in relation to the representative compound. This method can be used to determine *Relative Toxicity Coefficient* (RTC) (mutagenic,

---

<sup>1</sup> Institute of Machine Design and Operation, Faculty of Mechanical Engineering, Wrocław University of Technology, ul. Wybrzeże Wyspiańskiego 27, 50-370 Wrocław, phone 71 347 79 18, email: anna.janicka@pwr.wroc.pl

carcinogenic, irritant or sensitize) for all substances from the group. Because of discussible, law-based toxicity equivalent factors or relevant toxicity coefficients measures of mixtures toxicity the direct methods of toxicity estimation are needed to be developed [3]. The example is an *in-vitro* method which has been proposed and developed by the article author.

## Methodology

The indoor air samples was up-taken from two new (month after manufacture date) different brands vehicles interior: Japanese (vehicle A) and German (vehicle B) production, same class, similar equipment.

The samples of inner air were uptaken by active coal tubes (for chromatography) and based on the ISO/DIS 12219-1draft international standard [d] by special flasks with human lung cells previously prepared in Institute of Immunology and Experimental Therapy of Polish Academy of Science laboratories.

The sampler was put into popular, brand new, passenger-vehicle interior and plugged-in to aspirator (ASP II) the localization of system inlet is presented on Figure 1 and exposed for 4 hours.

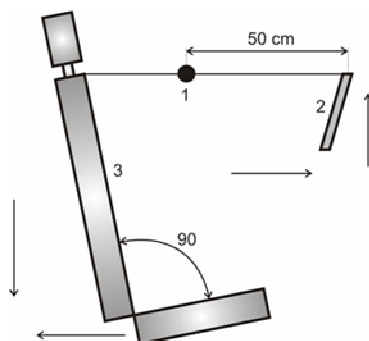

Fig. 1. Schematic arrangement of the sampling position in test vehicle: 1 - sampling point, 2 - steering wheel, 3 - seat with head rest

After sampling procedure the samplers consist standardized cell-culture system (human cell line A549 was analyzed. Cell growth, cell morphology and cell viability were used as parameters to determine the cytotoxicity of vehicle interior atmosphere. The measure the lethality effect on cells was determined spectrophotometrically with the use of a mitochondrial enzyme activity assay for mitochondrial succinat dehydrogenase activity by 3-(4,5-dimethylthiazol-2-yl)-2,5-diphenyltetrazolium bromide (MTT assay).

The A549 cells are maintained in Dulbecco's modified Eagle's minimum essential medium (DMEM), and the L929 cells were kept in Eagle's supplemented with 10% calf serum (c.s), 2 mM L-glutamine, antibiotics (100 U/cm<sup>3</sup> penicillin and 100 lg/cm<sup>3</sup> streptomycin).

According to Polish standard (PN-EN ISO 10993-5) cytotoxicity is investigated on two cells lines. Measuring in vitro growth of mouse fibroblast L929 and human A549 cell line.

For cytotoxicity test, the cells are seeded in the 24-well plates (Nunc) of 1 cm<sup>3</sup> at density of 2x10<sup>5</sup> cells/cm<sup>3</sup> in the culture medium Eagle's or DMEM with 2% calf serum, penicillin and streptomycin is deposited into each well. Samples of the tested samples contain VOCs are added to prepared cells, which are then incubated for 24, 48 and 72 h at 37°C in the atmosphere of 5% CO<sub>2</sub> in air.

VOC's samples were up taken by tubes with active coal (SKC lot 2000). The analysis was done according to Polish standard: PN-EN ISO 16017-1:2006. The qualitative and quantitative analysis was proceed on Varian 450 GC gas chromatograph with FID detector and capillary column was used for quantity and quality analysis. Carbon disulfide (CS<sub>2</sub>) was used for VOCs extraction from active coal. The chromatography conditions were: column temperature (110°C), dozers (150°C) and detectors (250°C).

Relative Toxicity Coefficients (RTC) were calculated for most characteristic in-vehicle compounds and VOCs group based on to two Polish standards of Maximum Allowed Concentrations: for indoor environment and for workplaces according to the Table 1.

Table 1

Relative Toxicity Coefficients for chosen compounds and VOCs groups

Chemicals name	Indoor Maximum Allowed Concentration (spaces A category) (IMAC) [ $\mu\text{g}/\text{m}^3$ ] [y]	Relative Toxicity Coefficient (RTC) according to IMAC (RTC-IMAC)	Maximum Allowed Concentration for Workplaces [ $\text{mg}/\text{m}^3$ ] (MACW) [x]	Relative Toxicity Coefficient (RTC) according to MACW (RTC-MACW)
Toluene	200	0.05	100	0.016
Benzene	10	1	1.6	1
Ethylbenzene	100	0.1	100	0.016
Xylene (isomers)	100	0.1	100	0.016
GROUPS				
Aromatic HC	66	0.15	49	0.033
Alifatic HC	250	0.04	678	0.002
Other VOCs	90	0.11	170	0.009
Total VOCs	135	0.07	229	0.007

## Results

The results were presented in tables and figures below.

Table 2

*In-vitro* testes results

Sample description	New vehicle 1 (brand a)			New vehicle 2 (brand b)		
	Number of cells <i>N</i> (72 h)	$\alpha =$ $N_i/N_{control}$	Dead cells [%]	Number of cells <i>N</i> (72 h)	$\alpha =$ $N_i/N_{control}$	Dead cells [%]
Control sample	94 000 000	1.00	0	240 000 000	1.00	0
Interior 1	40 000 000	2.35	2	8 000 000	30.00	26
Interior 2	32 000 000	2.94	10	3 200 000	75.00	75
Interior 3	38 000 000	2.47	6	4 500 000	53.33	50
Interior average	37 000 000	2.56	6	5 200 000	45.86	50
Background	81 000 000	1.16	0	190 000 000	1.26	0

In Table 2 the results of *in-vitro* tests toxicity are presented as number of dead cells after 72 hours of cultivation after exposition on vehicle interior atmosphere and number of cells in control sample to number of exposed cells ( $\alpha$ ) after 72 h.

In Figure 2 the comparison of the *in-vitro* tests results for both vehicles interiors is presented.

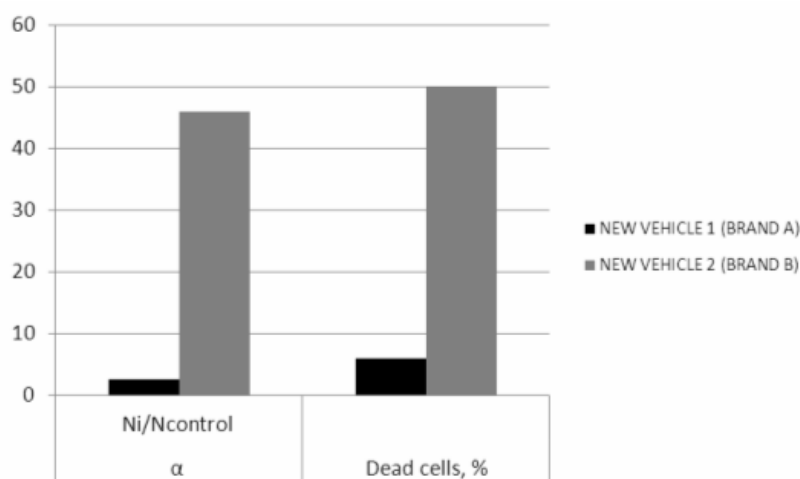

Fig. 2. Comparison of the *in-vitro* tests results for both vehicles interiors

*In vitro* tests indicate that the interior of vehicle 2 is almost 10 times more toxic than vehicle 1 for human lung cells. The atmosphere inside the second vehicle cabin after 4 hours of direct exposure caused a lethal effect for half the cell line and inhibited cell growth in almost 50% in comparison with the control sample. In the case of vehicle no. 1, the exposure caused the death of 6% of the culture and almost 3% inhibition of the human lung cell line growth.

In Table 3 the results of chromatographic analysis and computational results of toxicity indicators are presented.

Table 3

Relative Toxicity Coefficients for chosen compounds and VOCs groups

	New vehicle 1 (brand a)			New vehicle 2 (brand b)		
	Average concentration (Ci) [ $\mu\text{g}/\text{m}^3$ ]	RTC - IMAC	RTC - MACW	Average concentration (Ci) [ $\mu\text{g}/\text{m}^3$ ]	RTC - IMAC	RTC - MACW
Toluene	29.5	1.5	0.5	249.2	12.5	4.0
Benzene	39.3	39.3	39.3	114.8	114.8	114.8
Ethylbenzene	8.4	0.8	0.1	411.3	41.1	6.6
Xylene (isomers)	17.3	1.7	0.3	26.5	2.6	0.4
Groups						
Aromatic HC	188.7	28.8	6.2	608.4	92.8	19.8
Alifatic HC	1303.1	52.1	3.1	507.8	20.3	1.2
Other VOCs	185.4	20.6	1.7	275.8	30.6	2.6
Total VOCs	1677.2	124.1	11.7	1641.2	121.4	11.4



In Figures 3 to 5 the concentrations of VOCs groups and Relative Toxicity Coefficient (RTC) according to IMAC and MACW are compared for both vehicles.

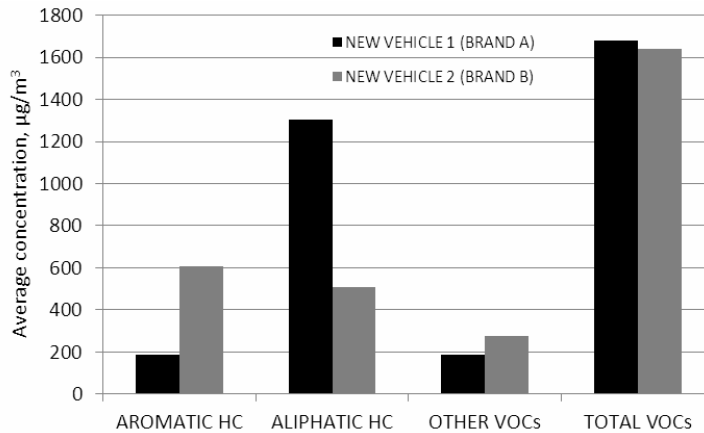

Fig. 3. Average concentration of VOCs groups in cabin air [ $\mu\text{g}/\text{m}^3$ ]

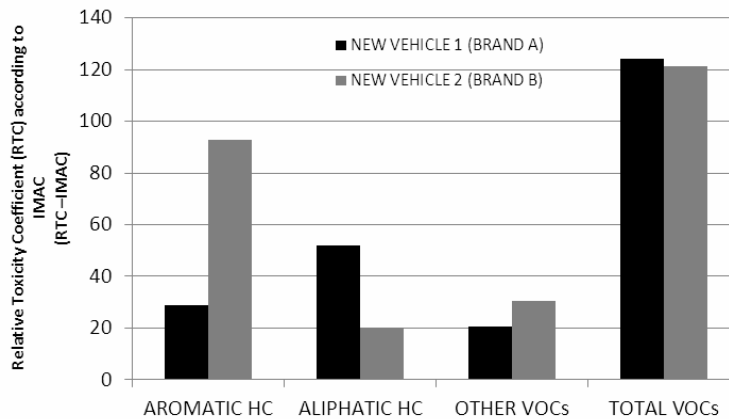

Fig. 4. Relative Toxicity Coefficient (RTC) according to IMAC

The difference between total VOCs concentrations in both vehicles is insignificant. The differences in VOCs group share are visible. In case of vehicle no 2 concentration of aromatic hydrocarbons is two times higher than in vehicle 2 interior atmosphere.

The computational toxicity indicators show the significant differences between using different bases of calculation methods (MAC for indoor atmosphere and MAC for workplaces).

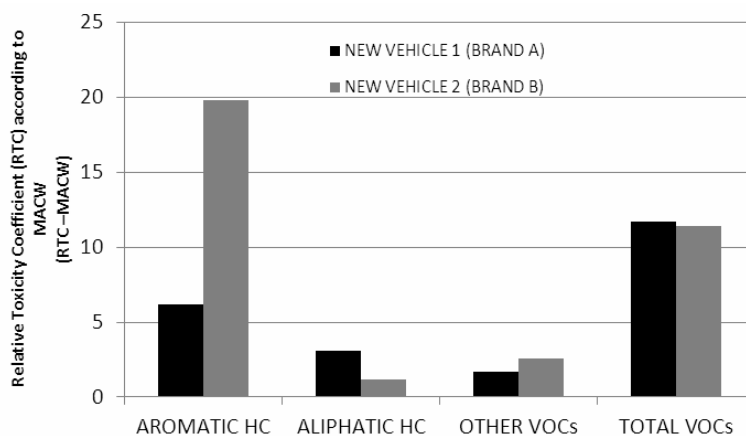

Fig. 5. Relative Toxicity Coefficient (RTC) according to IMAC

## Summary

Gaseous mixtures toxicity is complex and complicated problem for evaluation. Because of discussible, law-based computational toxicity indicators measures of mixtures toxicity the direct methods of toxicity estimation are needed to be developed. The example is the method which has been proposed and developed by the author article. Despite the fact that the total VOCs concentration is almost the same in cabin of both cars, proposed by the author *in vitro* tests on human lung cells indicates that interiors of two new vehicles (month after manufacture date), same class, similar equipment can be 10 times more toxic. It also proof that RTC methods need to be evaluated. The RTC calculations based on two different standards shows that the method is discussible but proofed toxicity determined effect for aromatic hydrocarbons. Compared with the *in vitro* tests it shows that very complicated effects of synergism can strongly impact on real toxic effect of volatile toxins on human respiratory system.

## References

- [1] Zawiślak M. Numerical modeling of vehicle interior in aspect of human exposure on volatile organic compounds. *Polish J Environ Studies*. 2012;21(5A):454-458.
- [2] Sarigiannis DA, Karakitsiosa SP, Gottic A, Liakosa IL, Katsoyiannisa A Exposure to major volatile organic compounds and carbonyls in European indoor environments and associated health risk. *Environ Int*. 2011;37(4):743-765. <http://dx.doi.org/10.1016/j.envint.2011.01.005>.
- [3] Janicka A. Method of toxicity estimation of gaseous mixtures emitted from different emission sources. *Polish J Environ Studies*. 2012;21(5A):134-139.
- [4] ISO/DIS 12219 (2011): Indoor air of road vehicles: Whole vehicle test chamber - Specification and method for the determination of volatile organic compounds in cabin interiors.
- [5] Rozporządzenie Ministra Pracy i Polityki Społecznej z dnia 29 listopada 2002 r. w sprawie najwyższych dopuszczalnych stężeń i natężeń czynników szkodliwych dla zdrowia w środowisku pracy.
- [6] Zarządzenie Ministra Zdrowia i Opieki Społecznej z dnia 12 marca 1996r. w sprawie najwyższych dopuszczalnych stężeń i natężeń czynników szkodliwych dla zdrowia, wydzielanych przez materiały budowlane, urządzenia i elementy wyposażenia w pomieszczeniach przeznaczonych na pobyt ludzi.

---

## **TOKSYCZNOŚĆ WNĘTRZA POJAZDU: TESTY IN VITRO JAKO NOWA METODA OCENY TOKSYKOLOGICZNEJ POWIETRZA WEWNĄTRZ KABINY POJAZDU**

Instytut Konstrukcji i Eksploatacji Maszyn, Wydział Mechaniczny, Politechnika Wroclawska

**Abstrakt:** W artykule podjęto dyskusję nad trudnym problemem oceny toksyczności mieszanin gazowych. Problem jest istotny szczególnie w aspekcie jakości powietrza w środowisku przebywania człowieka, a zwłaszcza w pomieszczeniach zamkniętych. Takim środowiskiem jest wnętrze kabiny pojazdu, w którym stężenia związków toksycznych są szczególnie wysokie. W artykule przedstawiono metodę oceny toksyczności mieszanin gazowych opartą o badania in vitro w kabinach pojazdów jako jedną z możliwości jej aplikacji. Zaprezentowano wyniki badań mających na celu ocenę toksykologiczną wnętrza różnego typu nowych pojazdów samochodowych w warunkach parkingowych. Wyniki badań zestawiono z pomiarem stężeń lotnych związków organicznych (metoda chromatografii gazowej z detekcją mas).

**Słowa kluczowe:** wnętrze pojazdu, lotne związki organiczne, pomiary jakości powietrza wewnętrznego, toksyczność



Bartosz KAŻMIERCZAK<sup>1</sup>

## MODELLING OF DISCHARGES FROM STORM OVERFLOWS ON A COMBINED SEWAGE SYSTEM

### MODELOWANIE ZRZUTÓW ŚCIEKÓW Z PRZELEWÓW BURZOWYCH NA KANALIZACJI OGÓLNOŚPŁAWNEJ

**Abstract:** A simulation of the functioning of a modern overflow with a throttling pipe on a combined sewage system was conducted in this work. For the modelling of storm overflow activity a combined drainage area of  $F = 50$  ha was suggested. The overflow was loaded with sewage and wastewater. A typical, triangular hydrograph of the wastewater inflow to the storm overflow was applied here. The given hydraulic model of storm overflow activity includes a series of characteristic, occurring in sequence phases of filling and emptying of the overflow chamber. The phases were distinguished with the description of boundary conditions in reference to the precisely determined range of variables during the fillings and flows. On the basis of the formulated hydraulic and mathematical models of the storm overflow activity, a computer programme for the numerical simulation of the functioning of the aforementioned overflows was developed.

**Keywords:** storm overflow, combined sewage system, mathematical modelling

#### Introduction

Storm overflows are mainly applied in combined sewage systems in order to protect sewage-treatment plants from hydraulic overload and operation efficiency decline, as well as to reduce the dimensions of a trunk sewer behind an overflow. A hydraulic task of a storm overflow is the distribution of the maximum sewage inflow stream  $Q_d$  to the object, into two separate streams [1-3]:

- $Q_o$  - outflow to the sewage-treatment plant ( $Q_o = Q_d - Q$ ),
- $Q$  - outflow to the receiver ( $Q = Q_d - Q_o$ ).

So far, traditional lateral storm overflow constructions have been applied in sewage systems. They consist of low overflow edges, which are placed at the height of a regular fulfilment next to the boundary stream in the inflow drain, without appliances used to throttling of the outflow towards the sewage - treatment plant. Hydraulic efficiency of these overflows is low, and therefore the length of the overflow edges is sizeable, because of high inertia (velocity) of the flowing sewage in the inflow drain and overflow chamber. The unconventional constructions - with high overflow edges and outflow stream throttling appliances - constitute an alternative for the conventional lateral overflows. Throttling appliances, such as throttling pipes, systems of elbows, bends or hydrodynamic regulators enable the accumulation of the sewage in the overflow chamber and in the inflow drain. Unconventional overflows have gained an advantage over the traditional ones due to the following facts [3]:

- flow velocity reduction in the range of the overflow chamber and the increase of hydraulic efficiency, and therefore significant reduction of the overflow edge length,
- high level of protection of the sewage-treatment plant from hydraulic overload,

---

<sup>1</sup> Institute of Environmental Protection Engineering, Wrocław University of Technology, pl. Grunwaldzki 9, 50-370 Wrocław, email: bartosz.kazmierczak@pwr.wroc.pl

- the use of channel retention in reducing the time and frequency of the overflow activity throughout the year.

### Storm overflow designing

While designing storm overflows, qualitative, as well as quantitative criteria of the receiver water protection must be taken into consideration. The criteria can be expressed by the allowed number of storm discharges during the year (their duration or allowed volume), or by the admissible concentration and/or the load of pollution drained off in storm discharges to the receiver. In case of storm overflows, the limited value of the average annual number of sewage discharges, depending from the type of sewage system and the receiver constitutes an obligatory quantitative criterion in Poland. As an example, in municipal sewage system the wastewater from the storm overflows might be drained off to the inland surface waters - moving or marginal, unless the average annual number of runs of the particular overflows exceeds 10 - according to the Ordinance of the Minister of Environment of 2006 [4]. In the absence of design data needed to verify the above quantitative criterion, the sewage from storm overflows in the municipal combined sewage-treatment plant with PE under 100 000, and at the beginning of the overflow activity, the volume stream of the mingled inflow sewage is at least four times greater than the average daily in a year stream of sewage in the period of no precipitation  $Q_{\dot{s}c(p.b.)}$ .

With regard to the above criteria, the value of the boundary volume stream  $Q_{gr}$  in the drain before the overflow, determining the initiation of the sewage discharge to the receiver can be represented by the following model [3]:

$$Q_{gr} = Q_{\dot{s}c(p.b.)} + Q_{dgr} + \sum Q_{oi}$$

where:  $Q_{\dot{s}c(p.b.)}$  - authoritative sewage inflow stream in the period of no precipitation (domestic sewage, industrial liquid waste and incidental and infiltration waters),  $Q_{dgr}$  - boundary stream of the wastewater inflow from the direct drainage area,  $\sum Q_{oi}$  - total number of inflows from the storm overflows situated at higher locations.

It must be considered that with the maximum (design) wastewater inflow to the overflow  $Q_{d(max)}$ , the outflow from the overflow towards the sewage-treatment plant  $Q_{o(max)}$  will be larger than the stream  $Q_{gr}$ , as a result of accumulation of the waste flowing over the overflow edge. Therefore, it is permitted:

- $Q_{o(max)} = \beta Q_{gr} = (1.2 \div 1.5) Q_{gr}$  - in Poland [5],
- $Q_{o(max)} = \beta Q_{gr} = (1.1 \div 1.2) Q_{gr}$  - in Germany [1, 6].

The value of the boundary stream  $Q_{dgr}$  can be determined with dilution method, the crux of which is the initial waste dilution coefficient  $n_{rp}$  (at the initial point of flowing over the overflow edge), defined as:

$$n_{rp} = \frac{Q_{dgr}}{Q_{\dot{s}c(p.b.)}}$$

thus

$$Q_{dgr} = n_{rp} \cdot Q_{\dot{s}c(p.b.)}$$

In Poland storm overflows applied in municipal combined sewage systems (in agglomerations with  $PE \leq 100000$ ) should be designed for the initial dilution value of  $n_{rp} \geq 3$ , then the boundary outflow towards the sewage-treatment plant can be defined as [3, 7]:

$$Q_{gr} = (1 + n_{rp}) Q_{sc(p.b.)} + \sum Q_{oi}$$

The computational scheme for storm overflow is shown in Figure 1.

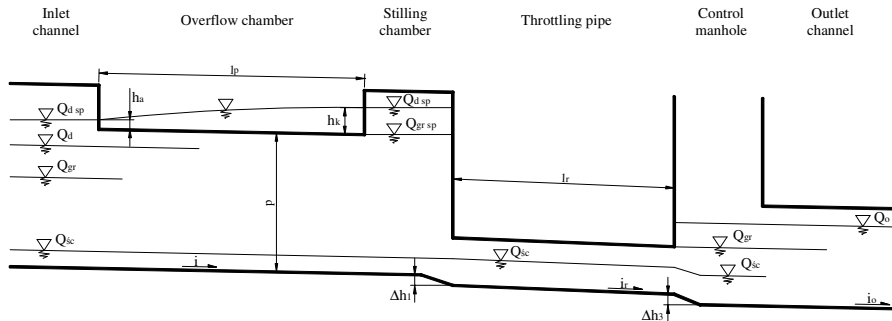

Fig. 1. Computational scheme for a non-conventional storm overflow

In order to design the algorithm applied in dimensioning of the improved storm overflows with a throttling pipe in a combine sewage system, the following course of operation was established [3]:

- for the sewage stream in no precipitation periods  $Q_{sc(p.b.)}$  a throttling pipe diameter is selected - taking into consideration its conditions of self-cleaning;
- for the boundary volume stream  $Q_{gr}$  of the sewage inflow flowing towards the overflow, the proper height of the side overflow edge is assumed - taking into consideration the hydraulic conditions of subcritical flow occurrence in the range of the overflow, and subsequently the necessary length of the throttling pipe is calculated;
- for the maximum stream  $Q_d$  the required distribution of the flows on the overflow:
  - for the assumed outflow (through the throttling pipe) flowing towards the sewage-treatment plant: *eg*  $Q_o \in [1.1Q_{gr}; 1.2Q_{gr}]$  the losses in the throttling pipe and the height of the overflow layer  $h_k$  at the end of the overflow are calculated;
  - for the outflow stream (through the overflow) flowing towards the receiver:  $Q = Q_d - Q_o$  and for the calculated height  $h_k$  the height of the overflow layer  $h_a$  is determined iteratively at the beginning of the overflow, as well as the length of the overflow edge  $l_p$ .

### Hydraulic and mathematical models of a storm overflow

Designing of discharging objects, such as storm overflows, has been based on the maximum flows - the quasi-determined ones. Therefore the variability of the sewage stream is not taken into account as a function of time. At the stage of designing it is not possible to answer the questions concerning the multiplicity of the overflows activity during the year,

or their activity time and the volume of discharges. The control of these parameters is possible only through hydrodynamic modelling [3, 8-12].

The assumed model of a storm overflow functioning includes a hydraulic description of the following processes: the inflow of the sewage to the object, the outflow to the sewage-treatment plant, the overflow through the side edge to the receiver, as well as the retention in the overflow chamber. The volume ( $V$ ) change of the sewage accumulated in the overflow chamber in the time ( $t$ ) can be defined as:

$$dV(t) = Q_d(t)dt - Q_o(t)dt - Q(t)dt$$

The sewage outflow stream  $Q_o$  flowing towards the sewage-treatment plant, as well as the sewage discharge stream  $Q$  flowing through the side overflow, are both dependent from the overflow chamber fulfilment height  $H$ . The sewage outflow volume stream flowing through the throttling pipe (under pressure) towards the sewage-treatment plant is calculated digitally, by the solution of a system of equations concerning hydraulic losses (Fig. 1):

$$\begin{cases} \Delta H_o(Q_o) = \left( \zeta_w + \lambda \frac{l_r}{d_r} + \alpha_r \right) \frac{8Q_o^2}{g\pi^2 d_r^4} \\ H - p = H_o(Q_o) + \Delta H_o(Q_o) - (il_u + p + \Delta h_1 + i_r l_r + \Delta h_2) \end{cases}$$

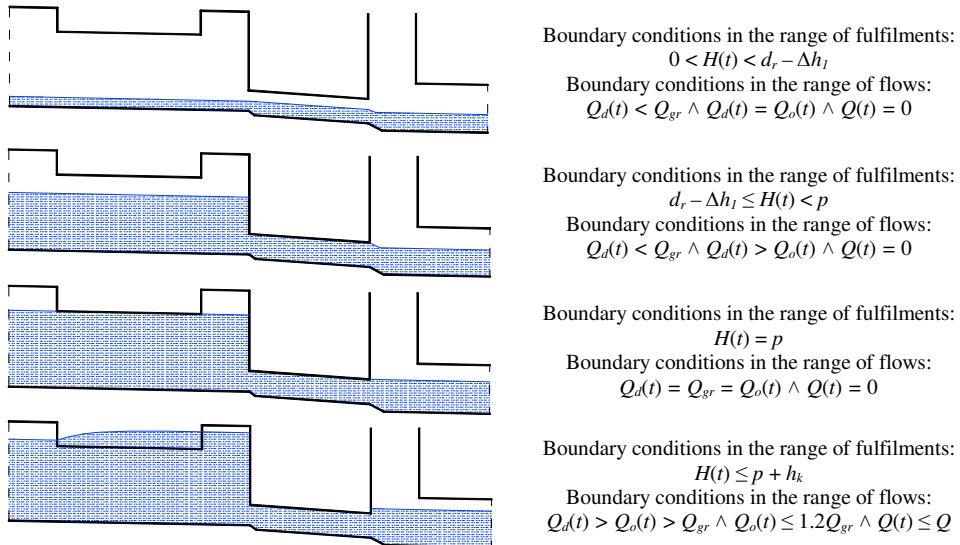

Fig. 2. Overflow chamber filling phases

The sewage discharge to the receiver occurs when the fulfilment  $H$  exceeds the overflow edge height  $p$  and it is calculated from the model:



$$Q = \frac{2}{3} l_p \mu \sqrt{2g} (H - p)^{3/2}$$

where  $\mu$  - side weir discharge coefficient  $\mu \in [0.5; 0.6]$ .

The given hydraulic model of a storm overflow activity includes a series of characteristic, occurring in sequence phases of filling (Fig. 2) and emptying (in analogy) of the overflow chamber. The phases were distinguished with the description of boundary conditions in reference to the precisely determined range of variables during the fulfilments and flows.

### Exemplary storm overflow functioning simulation

For the modelling of a storm overflow activity, a combined drainage area of  $F = 50$  ha was suggested. Making an assumption that a substitute (weighted average) run-off coefficient of the rain from the drainage area amounts  $\psi = 0.25$ , its reduced surface that takes part in the rain water run-off formation, will amount  $F_{r,r} = 12.5$  ha. An average population density of 150 inhabitant per one hectare was assumed, thus a number of inhabitants was estimated to be about 5000. On the basis of the German recommendations [13, 14], a unit rate (on an inhabitant)  $q_j = 0.005$  dm<sup>3</sup>/s was assumed as an authoritative (maximum per hour) domestic wastewater outflow. Hence the domestic wastewater outflow stream flowing from the model drainage area was estimated as 0.038 m<sup>3</sup>/s. Furthermore,  $t = 20$  minutes was assumed as the flow time in the trunk sewer, authoritative to the overflow design. The wastewater stream was calculated from the formula for the maximum precipitation amount in Wroclaw conditions (in [mm]) [15, 16], assuming design rainfall frequency  $C = 2$  years:

$$h = -4.583 + 7.412t^{0.242} + (97.105t^{0.0222} - 98.675) \left( -\ln \frac{1}{C} \right)^{0.809}$$

The result of the calculation is the maximum sewage inflow stream flowing towards a storm overflow  $Q_{m(C)} = 1.512$  m<sup>3</sup>/s. Thus the total sewage inflow volume stream flowing towards the storm overflow amounts  $Q_d = Q_{d(\max)} = 1.550$  m<sup>3</sup>/s. The division of sewage streams was designed on the basis of dilution method, assuming  $n_{rp} = 5$ , taking into account the verification of the number of allowed storm discharges to the receiver, smaller than 10 in a year. The boundary sewage inflow stream flowing towards the overflow, according to (4), amounts:  $Q_{gr} = (1 + 5)Q_{sc(p,b)} = 0.228$  m<sup>3</sup>/s.

On the basis of the assumed sewage division on the overflow and by the assumption that the maximum sewage outflow volume stream flowing towards the sewage-treatment plant can amount  $Q_o = 1.2Q_{gr} = 0.274$  m<sup>3</sup>/s, the following storm overflow parameters were determined:

- an egg-shaped inflow drain 1.20 x 1.80 m with the slope of the drain bottom  $i = 1.00\%$ ,
- a overflow edge with the height  $p = 1.20$  m and length  $l_p = 2.56$  m ( $\mu = 0.523$ ),
- a throttling pipe with the diameter  $d_r = 0.40$  m, length  $l_r = 58.0$  m and the bottom slope  $i_r = 2.50\%$ ,
- an egg-shaped outflow drain: 0.60 x 0.90 m<sup>2</sup> with the bottom slope  $i_o = 1.67\%$ .

A typical, triangular hydrograph of the sewage inflow towards the storm overflow was applied here (Fig. 3).

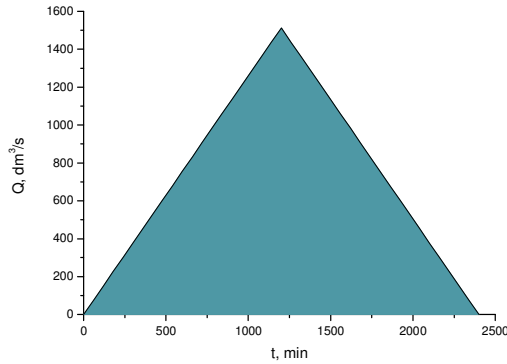

Fig. 3. The assumed hydrograph of wastewater inflow towards a storm overflow

On the basis of the formulated hydraulic and mathematical models of the storm overflow activity, a computer programme for the numerical simulation of the functioning of the aforementioned overflows was developed. The results of the simulation with the applied loads were presented in Table 1. On account of a high number of result data (one second time interval), only the data for the crucial moments of the simulation were presented in Table 1: simulation start ( $t = 0$  s), sewage discharge start ( $t = 195$  s), maximum temporary sewage discharge ( $t = 1200$  s), sewage discharge end ( $t = 2252$  s) and simulation end ( $t = 2400$  s).

Table 1

The results of the simulation of a storm overflow functioning

$t$ , [s]	$Q_d$ [ $m^3/s$ ]	$Q_o$ [ $m^3/s$ ]	$Q$ [ $m^3/s$ ]	$\Sigma V_d$ [ $m^3$ ]	$\Sigma V_o$ [ $m^3$ ]	$\Sigma V$ [ $m^3$ ]
0	0.038	0.038	0.000	-	-	-
195	0.284	0.229	0.008	31.4	26.5	0.0
1200	1.550	0.274	1.275	953.5	284.4	662.8
2252	0.224	0.228	0.004	1886.2	553.2	1328.1
2400	0.038	0.045	0.000	1905.5	577.4	1328.1

With the applied load the overflow starts discharging the sewage into the storm drain at 195 s. At 1200 s the maximum temporary sewage discharge  $Q_{(\max)} = 1.275$   $m^3/s$  occurs. The sewage discharge lasts until 2252 s (over 34 minutes). The total volume of the sewage discharged to the receiver in this time amounts  $V = 1328.1$   $m^3$ , whereas towards the sewage-treatment plant flows the volume of  $V_o = 577.4$   $m^3$  (the total inflow towards the overflow  $V_d = 1905.5$   $m^3$ ). The hydrographs of the sewage flow and discharge were presented in Figure 4.

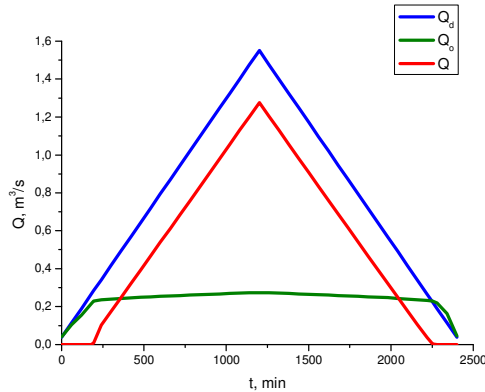

Fig. 4. The hydrographs of the sewage inflow towards the overflow, the outflow towards the sewage-treatment plant and the outflow to the storm drain through the overflow

The hydrographs in Figure 4 confirm an appropriate protection level of the sewage-treatment plant from the hydraulic overload through the application of throttling on a storm overflow. The maximum outflow stream towards the sewage-treatment plant amounts  $Q_o = 0.274 \text{ m}^3/\text{s}$ , and therefore exactly  $1.2Q_{gr}$ .

### Conclusions and summary

Current methods of designing storm overflows do not take into account the frequency of storm discharges to the receiver, as well as they do not offer the possibility of their duration and volume determination and thus they do not allow for the assessment of pollution load that is drained off in discharges towards receivers. The simulations of storm overflows functioning allow for determination of these parameters for already designed overflow and for any assigned load. Therefore they constitute a valuable instrument supporting the process of designing this type of objects, as it has been proved in this work.

The simulation of a storm overflow functioning on a combined sewage system, conducted in this work, proved a high level of sewage-treatment plant protection from a hydraulic overload by the application of modern, unconventional storm overflows. Irrespective of the assigned load, sewage outflow stream towards the sewage-treatment plant is stabilized on a demanded level.

### References

- [1] Arbeitsblatt ATV-A111: Richtlinien für die hydraulische Dimensionierung und den Leistungsnachweis von Regenwasser-Entlastungsanlagen in Abwasserkanälen und -leitungen. Hennef: GfA; 1994.
- [2] Fidala-Szope M. Surface Waters Protection from the Rain Water and Separate Sewage Systems Discharges. Warsaw: IOŚ; 1997.
- [3] Kotowski A. The Principles of Safe Dimensioning of Sewage Systems. Warszawa: Seidel-Przywecki; 2011.
- [4] Ordinance of the Minister of Environment dated 24 July 2006 on the conditions that must be fulfilled when entering sewage into waters or land, and on exceptionally harmful substances. Journal of Laws No. 137 of 31 July 2006, item 984.

- [5] Błaszczyk P. The Principles of Sewage Systems Planning and Designing in Municipal and Industrial Agglomerations and Large Cities. Warsaw: IKŚ; 1983.
- [6] Arbeitsblatt ATV-A128: Richtlinien für die Bemessung und Gestaltung von Regenentlastungsanlagen in Mischwasserkanälen. Hennef: GfA; 1998.
- [7] Kotowski A. Design of separators and high side weirs for storm sewers. *Ochrona Środow.* 2000;22(2):25-30.
- [8] EN 752: Drain and sewer systems outside buildings, 2008.
- [9] Kaźmierczak B, Kotowski A.: Verification of Storm Water Drainage Capacity in Hydrodynamic Modeling. Wrocław: The Publishing House of Wrocław University of Technology; 2012.
- [10] Kaźmierczak B, Kotowski A, Dancewicz A. Verification of storm sewerage sizing methods with the hydrodynamic model SWMM 5.0 for the municipality of Wrocław. *Ochrona Środow.* 2012;34(2):25-31.
- [11] Słyś, D, Stec A. Hydrodynamic modelling of the combined sewage system for the city of Przemyśl. *Environ Protect Eng.* 2012;38(4):99-112. DOI: 10.5277/EPE120409.
- [12] Rossman LA. Storm Water Management Model. User's Manual. Version 5.0. Cincinnati: United States Environmental Protection Agency; 2010.
- [13] Arbeitsblatt DWA-A118: Hydraulische Bemessung und Nachweis von Entwässerungssystemen. DWA, Hennef, 2006.
- [14] Schmitt T. Kommentar zum Arbeitsblatt A 118 "Hydraulische Bemessung und Nachweis von Entwässerungssystemen". Hennef: DWA; 2000.
- [15] Kotowski A, Kaźmierczak B, Dancewicz A. The modelling of precipitations for the dimensioning of sewage systems. The Publishing House of the Civil Engineering Committee the Polish Academy of Sciences. Studies in Engineering no. 68, Warsaw; 2010.
- [16] Kaźmierczak B, Kotowski A. Depth-Duration-Frequency rainfall model for dimensioning and modelling of Wrocław drainage systems. *Environ Protect Eng.* 2012;38(4):127-112. DOI: 10.5277/EPE120411.

## **MODELOWANIE ZRRZUTÓW ŚCIEKÓW Z PRZELEWÓW BURZOWYCH NA KANALIZACJI OGÓLNOŚPŁAWNEJ**

Instytut Inżynierii Ochrony Środowiska, Politechnika Wrocławska

**Abstrakt:** W pracy przeprowadzono symulację działania nowoczesnego przelewu z rurą dławiącą na kanalizacji ogólnospławnej. Na potrzeby modelowania działania przelewu burzowego zaproponowano modelową zlewnię ogólnospławną o powierzchni  $F = 50$  ha. Przelew obciążono ściekami bytowo-gospodarczymi oraz deszczowymi. Założono typowy, trójkątny hydrogram dopływu ścieków deszczowych. Model działania przelewu burzowego ujmuje szereg charakterystycznych i występujących kolejno faz napełniania i opróżniania komory przelewowej, które zostały wyróżnione opisem warunków brzegowych w odniesieniu do ściśle określonego zakresu zmiennych w czasie napełnień i przepływów. Na podstawie sformułowanych modeli hydraulicznego i matematycznego funkcjonowania przelewów burzowych opracowano program komputerowy do numerycznej symulacji działania przedmiotowych przelewów.

**Słowa kluczowe:** przelew burzowy, kanalizacja ogólnospławna, modelowanie matematyczne

Aleksandra KIECAK<sup>1</sup>, Ewa KRET<sup>1</sup> and Grzegorz MALINA<sup>1</sup>

## INTRINSIC BIODEGRADATION POTENTIALS IN GROUNDWATER CONTAMINATED WITH TRI- AND TETRACHLOROETHENE IN THE VICINITY OF NOWA DEBA WATERWORKS

### OCENA MOŻLIWOŚCI SAMOISTNEJ BIODEGRADACJI TRI- I TETRACHLOROETENU W WODACH PODZIEMNYCH W REJONIE UJĘCIA NOWA DEBA

**Abstract:** *Natural Attenuation* (NA) in the case of groundwater contaminated with organic compounds relies mainly on intrinsic biodegradation processes. The aim of reliance on natural processes is to achieve site-specific cleanup objectives within reasonable time frames and costs. Such approach may be considered as a risk reduction/remedial option for groundwater contaminated with *trichloroethene* (TCE) and *tetrachloroethene* (PCE) in the vicinity of Nowa Deba waterworks. This case study presents implementation of the USEPA's guideline „Technical protocol for evaluating natural attenuation of chlorinated solvents in ground water” to assess intrinsic biodegradation potentials in contaminated groundwater in the case of Nowa Deba. Literature and field data collected from wells and piezometers were used to develop a conceptual model of contaminants' fate and transport from a source to a receptor. The intrinsic biodegradation was investigated basing on available analytical parameters (*eg* concentrations of oxygen, nitrates, chlorides, and pH, TOC and temperature) that are considered as indicators of TCE and PCE transformation. Preliminary screening was done by giving certain points for these parameters, and interpreted in order to assess intrinsic biodegradation potentials. The results indicate inadequate evidence for intrinsic biodegradation (reductive dehalogenation) of TCE and PCE, thus a limited potential for NA as a remedial/risk reduction option in the studied case, unless some measures for enhancement of TCE and PCE intrinsic biodegradation are applied.

**Keywords:** intrinsic biodegradation, TCE, PCE, risk reduction, remediation

### Introduction

The term *Natural Attenuation* (NA) refers to the reliance on natural processes to achieve site-specific cleanup objectives within a reasonable time frame and costs [1]. The NA includes a variety of destructive and non-destructive physical, chemical, and biological processes like: dispersion, dilution, adsorption, volatilization, chemical or biological stabilization, biodegradation (biotransformation) or destruction of contaminants [2]. In the case of groundwater contaminated with organic compounds NA relies mainly on intrinsic biodegradation processes. Such approach may be considered as a risk reduction/remedial option for groundwater contaminated with *trichloroethene* (TCE) and *tetrachloroethene* (PCE) in the vicinity of Nowa Deba waterworks (south-east Poland).

TCE and PCE are halogenated alkenes used commonly as industrial solvents. Generally, they are present both, as: DNAPLs (*denser than water non-aqueous phase liquids*) and dissolved in groundwater [3]. Biodegradation is usually the most important destructive process leading to reduction of the contaminant loads in groundwater, therefore it is an important factor to consider [4]. The biodegradation of TCE and PCE may occur

<sup>1</sup> Faculty of Geology, Geophysics and Environmental Protection, AGH University of Science and Technology, al. A. Mickiewicza 30, 30-059 Kraków, phone 12 617 38 97, email: akiecak@geol.agh.edu.pl

firstly by reductive dehalogenation in anaerobic conditions or secondly by cometabolism in aerobic conditions. Reductive TCE and PCE is associated with the accumulation of daughter products (DCE and VC) and an increase in chloride [4].

To estimate the intrinsic TCE and PCE biodegradation rates different lines of evidence can be used [5]. Microcosm studies can physically demonstrate that NA is occurring but they are time consuming and expensive [4]. An effective alternative is to base the estimation on data about groundwater and soil chemistry (biogeochemistry and hydrogeochemistry), as well as on hydrogeological conditions.

To evaluate whether NA by itself, or in conjunction with other remedial technologies is sufficient to achieve site-specific remedial objectives as concerns TCE and PCE contaminated groundwater in the vicinity of Nowa Deba, the USEPA's guideline „Technical protocol for evaluating natural attenuation of chlorinated solvents in ground water” [4] was implemented.

## Methodology

The protocol is designed to evaluate the fate of chlorinated aliphatic hydrocarbons in groundwater [4]. It is aimed at improving the characterization process for sites at which a remedy involving *monitored natural attenuation* (MNA) is being considered, and contains methods and recommended strategies for completing the remedial investigation process. Emphasis is placed on developing a more complete understanding of the site through the conceptual site model process, early pathways analysis, and evaluation of remedial processes. Understanding the contaminant transport in the subsurface is essential for a technically justified evaluation of a MNA-based remedial option.

According to the protocol, firstly available data about site (groundwater and soil chemistry, hydrogeological conditions, site history) and contamination must be collected. Basing on that the conceptual model can be developed. Next the MNA assessment process, which involves a six-step screening method (Fig. 1) [4, 6] can be performed.

Assessing the intrinsic biodegradation potentials is based on assigning a specified number of “points” depending on the concentration or value of the geochemical indicators of TCE and PCE transformation (oxygen, nitrates, chlorides, pH, TOC, temperature) observed in the wells. The “points” can be awarded only if the concentration of a geochemical indicator is within the range specified in the screening criteria, and if the indicator is not a constituent of the original contaminant source. The “points” are added and interpreted based on the guideline to determine whether biodegradation is occurring at the selected location [6]. Table 1 presents the interpretation of given “points”.

Table 1

The interpretation of “points” for MNA (*via reductive dehalogenation - RD*) assessment process [4]

Score	Interpretation
0 to 5	Inadequate evidence for anaerobic biodegradation (RD) of chlorinated organics
6 to 14	Limited evidence for anaerobic biodegradation (RD) of chlorinated organics
15 to 20	Adequate evidence for anaerobic biodegradation (RD) of chlorinated organics
>20	Strong evidence for anaerobic biodegradation (RD) of chlorinated organics

Three points were selected to characterize the Nowa Deba site: a piezometer M-5 located about 1100 m from source area, and two wells: S-2tr (about 900 m from source area) and S-6b (about 2400 from source area). Preliminary screening was done by giving certain points for certain parameters, and interpreted in order to asses intrinsic biodegradation potentials according to the scoring scheme provided by Wiedemeier et al. [4].

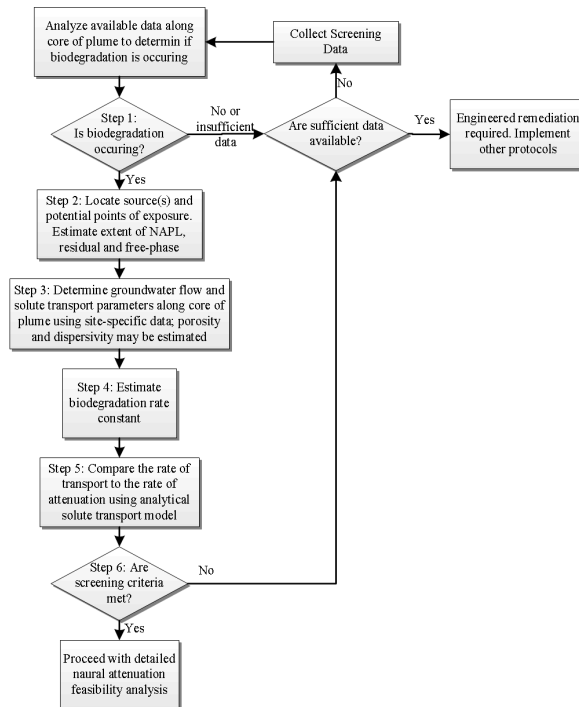

Fig. 1. Screening process flow chart for evaluating NA of chlorinated solvents in groundwater (after [4, 6])

Characteristics of biogeochemistry involve description of range of geochemical indicators, shortly discussed below. *Dissolved oxygen* (DO) levels inform about aerobic/anaerobic conditions in the aquifer. Nitrates and sulfates concentrations below background values in areas with high organic carbon concentrations are indicative of denitrification and sulphate reduction, respectively [4]. Iron(II) is being produced at a site, where reductive dechlorination of alkenes is ongoing. Optimal pH range for reductive biodegradation pathway is 5-9. *Oxidation-reduction potential* (ORP) may indicate if reductive processes are likely to occur. *Total organic carbon* (TOC) informs about the carbon content that is an energy source and drives dechlorination. Temperature ( $T > 20^{\circ}\text{C}$ ) is also important, because at higher temperature biochemical processes are accelerated. *Dichloroethene* (DCE) or *vinyl chlorides* (VC) are metabolites of TCE and PCE biotransformation, and their presence (if not released at a site) indicates that reductive dehalogenation may take place.

## Results and discussion

### Site and contamination characteristics

In Nowa Deba (S-E Poland) the metal works “DEZAMET” established in 1939, firstly as an ammunition factory, have been operating until now in a restructured form. TCE and PCE were used there for degreasing the metal parts.

*Hydrogeological conditions.* Groundwater is connected with the Quaternary river deposits. The most permeable deposits occur in the bottom part of the aquifer. The Quaternary deposits attain thickness of over 30 m and are underlain by impermeable Miocene clay [7]. The aquifer is unconfined and depths to groundwater vary from 1.0 to 9.0 m. This aquifer is the main source of potable water in the Nowa Deba region, and the groundwater flow is predominately from south-east towards the waterworks.

*Contamination.* The contaminants’ distribution maps (Fig. 2) show that the source of TCE and PCE is located within the area of the former metal works “DEZAMET”. The contaminants have probably been releasing gradually for decades into soil and groundwater because of *eg* improper storage and usage with no or poor environmental concern [7]. TCE has already reached wells of the municipal waterworks while PCE is less widespread.

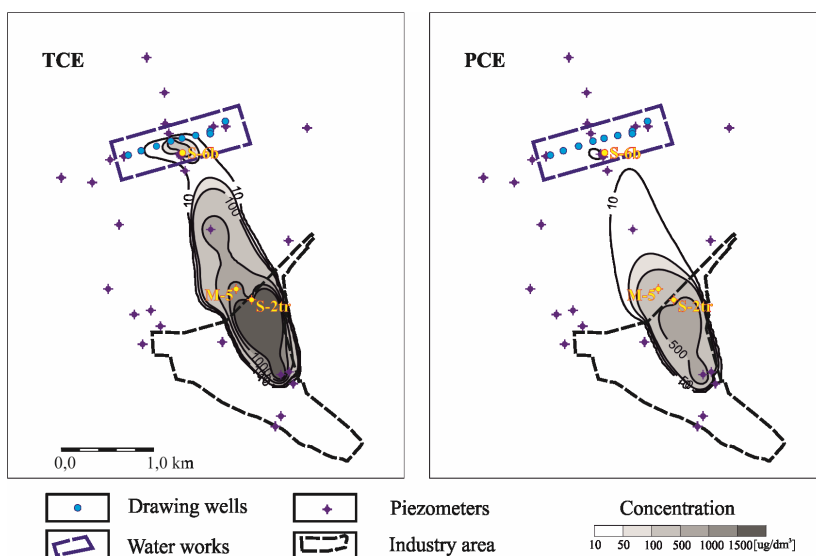

Fig. 2. TCE and PCE concentrations in groundwater at Nowa Deba

High TCE and PCE concentrations of up to 6130 and 694  $\mu\text{g}/\text{dm}^3$ , respectively, observed in some wells of the waterworks [8] exceed the limits for potable water [9]. Moreover, they are responsible for the “poor” chemical status of groundwater (class V) in the Nowa Deba region according to [10].

*A conceptual model.* A conceptual model of TCE and PCE fate and transport in groundwater in the vicinity of Nowa Deba (Fig. 3) was developed based on the “source - pathway - receptor” sequence [7]. The source is within the area of the former metal works



“DEZAMET”, while the municipal waterworks in Nowa Deba, supplying about 20 000 inhabitants with potable water, is the receptor affected by the contamination.

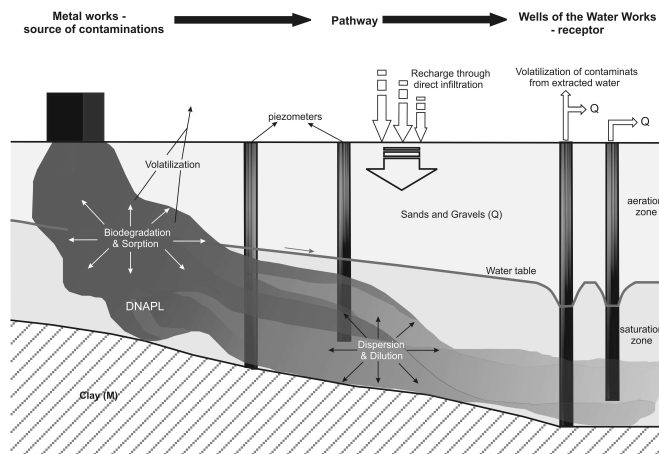

Fig. 3. Conceptual model of contaminants' fate and transport for Nowa Deba [7]

Table 2  
Analytical parameters and weighting for preliminary screening for anaerobic biodegradation processes<sup>aj</sup> at the Nowa Deba Region (after [4], changed)

Analysis	Concentration/ Value in the Most Contaminated Zone	Value	M-5		S-2tr		S-6b	
			Concent./ Value	Score	Concent./ Value	Score	Concent./ Value	Score
Oxygen	< 0.5 mg/dm <sup>3</sup>	3	0.42	3	4.60	0	0.23	3
	> 5 mg/dm <sup>3</sup>	-3						
Nitrate	< 1 mg/dm <sup>3</sup>	2	8.58	0	4.75	0	14.8	0
Iron II	> 1 mg/dm <sup>3</sup>	3	0.03	0	0.48	0	2.11	3
Sulfate	< 20 mg/dm <sup>3</sup>	2	76.5	0	113.0	0	88.8	0
Oxidation Reduction Potential (ORP) against Ag/AgCl electrode	< 50 mV	1	111	0	124	0	-5	1
	< -100 mV	2						
pH	5 < pH < 9	0	6.5	0	6.2	0	6.4	0
	5 > pH > 9	-2						
TOC	> 20 mg/dm <sup>3</sup>	2	3.7	0	2	0	1.1	0
Temperature	> 20°C	1	11.7	0	11.9	0	9.8	0
Alkalinity	> 2x background	1	147.3	1	51.2	1	0.0	0
Chloride	> 2x background	2	53.6	2	31.9	0	18.5	0
BTEX	> 0.1 mg/dm <sup>3</sup>	2	NA	0	ND	0	NA	0
PCE [µg/ dm <sup>3</sup> ]		0	147	0	243	0	ND	0
TCE [µg/ dm <sup>3</sup> ]		0	721	0	631	0	149	0
		2 <sup>aj</sup>						
VC [µg/ dm <sup>3</sup> ]		0	NA	0	ND	0	NA	0
		2 <sup>aj</sup>						
Total points awarded				6		1		7

<sup>aj</sup> Points awarded only if it can be shown that the compound is a daughter product (i.e., not a constituent of the source NAPL). NA - not analyzed, ND - not detected

### *Intrinsic biodegradation assessment*

*Characteristics of biogeochemistry.* Basing on DO levels it can be suspected that there are some anaerobic areas within the studied site. Concentrations of additional terminal electron acceptors (nitrates, sulfates) are out of the range specified in screening criteria. Ph is in optimal range for reductive dehalogenation, while ORP indicates that reductive dehalogenation pathway is not possible. Temperature criterion ( $> 20^{\circ}\text{C}$ ) can not be fulfilled normally under climate conditions in Poland for Quaternary groundwater that is also the case at described site. Non metabolites (daughter products) of TCE and PCE dehalogenation like DCE or VC are detected.

*Assessment.* The results of the intrinsic biodegradation assessment are summarized in Table 2. In selected locations the score is between 1 and 7 points, what indicates: "Inadequate/limited evidence for anaerobic biodegradation of chlorinated organics" (see Table 1).

### **Conclusions**

Intrinsic biodegradation of TCE and PCE via reductive dehalogenation was shown not to be enough efficient for risk reduction in the case of Nowa Deba. Therefore, the remedial option to achieve site-specific objectives can not be based exclusively on MNA. Natural processes have to be enhanced using *in situ remediation* (ISR) methods, like *eg permeable reactive barriers* (PRB) or *in situ chemical oxidation* (ISCO). Detailed description of site biogeochemistry and hydrogeochemistry along with the developed conceptual contaminants' fate and transport model were proved to be a valuable tool in assisting to select effective remediation measures for the studied case.

### **Acknowledgement**

Presented study was financially supported by the State Committee for Scientific Research of the Ministry of Scientific Research and Information Technology, Project No. NN525349238 and the AGH Project No. 15.11.140.068.

### **References**

- [1] Stroo HF, Herb WC, editors. *In situ Remediation of Chlorinated Solvent Plumes*. New York, USA: Springer; 2010.
- [2] Malina G. Risk evaluation and reduction of groundwater contamination from petrol stations. In: Lens P, Grotenhuis T, Malina G, Tabak H, editors. *Soil and Sediment Remediation: Mechanisms, Technologies, Applications*. London: IWA Publishing; 2005:437-457.
- [3] Kiecak A, Kret E, Malina G. Contamination of useful aquifers with tri- and tetrachloroethene: characteristics, hazards, fate and transport, and remediation. In: Malina G, editor. *Reclamation and Revitalization of Demoted Areas*. Poznań: Polskie Zrzeszenie Inżynierów i Techników Sanitarnych Oddział Wielkopolski; 2011:53-70.
- [4] Wiedemeier TH, Swanson MA, Moutoux A, Gordon K, Wilson JT, Wilson BH, Kampbell DH, Haas PE, Miller RN, Hansen JE, Chapelle FH. *Technical Protocol for Evaluating Natural Attenuation of Chlorinated Solvents in Ground Water*. Cincinnati, Ohio, USA: USEPA National Risk Management Research Laboratory, Office of Research and Development; 1998.
- [5] Witt ME, Klecka GM, Lutz EJ, Ei TA, Grosso NR, Chapelle FH. Natural attenuation of chlorinated solvents at Area 6, Dover Air Force Base: groundwater biogeochemistry. *J Contam Hydrol*. 2002;57(1-2):61-80. DOI: 10.1016/S0169-7722(01)00218-2.

- [6] Clement TP, Truex MJ, Lee P. A case study for demonstrating the application of U.S. EPA's monitored natural attenuation screening protocol at a hazardous waste site. *J Contam Hydrol.* 2002;59(1-2):133-62. DOI: 10.1016/S0169-7722(02)00079-7.
- [7] Szklarczyk T, Kret E, Grajales Mesa SJ, Kiecak A, Malina G. Multilayer numerical groundwater flow model in the area of Nowa Dęba waterworks. In: Dymaczewski Z, Jeż-Walkowiak J, editors. *Water supply and water quality.* Poznań: Polskie Zrzeszenie Inżynierów i Techników Sanitarnych Oddział Wielkopolski; 2012:411-431.
- [8] Kret E, Kiecak A, Malina G, Szklarczyk T. Evaluation of Quaternary groundwater chemical status exploited by waterworks in Nowa Dęba. *Biuletyn Państwowego Instytutu Geologicznego.* 2011;445:329-336.
- [9] Dz.U.2007.61.417. Rozporządzenie Ministra Zdrowia z dnia 29 marca 2007 r. w sprawie jakości wody przeznaczonej do spożycia przez ludzi.
- [10] Dz.U.2008.143.896. Rozporządzenie Ministra Środowiska z dnia 23 lipca 2008 r. w sprawie kryteriów i sposobu oceny stanu wód podziemnych.

## OCENA MOŻLIWOŚCI SAMOISTNEJ BIODEGRADACJI TRI- I TETRACHLOROETENU W WODACH PODZIEMNYCH W REJONIE UJĘCIA NOWA DĘBA

Wydział Geologii, Geofizyki i Ochrony Środowiska, Akademia Górniczo-Hutnicza, Kraków

**Abstrakt:** Samooczyszczenie (ang. *natural attenuation* - NA) w przypadku wód podziemnych zanieczyszczonych substancjami organicznymi polega głównie na samoistnej biodegradacji zanieczyszczeń. Oparcie remediacji na naturalnych procesach zakłada osiągnięcie wymaganych efektów oczyszczania specyficznych dla danego terenu przy zachowaniu rozsądnych ram czasowych i kosztów. Takie podejście może być zastosowane jako jedna z opcji likwidacji zagrożenia/remediacji wody podziemnej zanieczyszczonej *trichloroetenem* (TCE) i *tetrachloroetenem* (PCE) w rejonie ujęcia Nowa Dęba (południowo-wschodnia Polska). Do oceny możliwości samoistnej biodegradacji TCE i PCE w rejonie Nowej Dęby wykorzystano procedurę opisaną w dokumencie US EPA „Technical protocol for evaluating natural attenuation of chlorinated solvents in ground water”. Dane archiwalne oraz wyniki badań terenowych zostały użyte do opracowania modelu koncepcyjnego transportu zanieczyszczeń od ogniska do receptora. Samoistna biodegradacja była oceniana na podstawie dostępnych parametrów analitycznych (np. stężenia tlenu, azotanów, chlorków oraz pH, TOC i temperatury wody), które uważane są jako wskaźniki rozkładu TCE i PCE. Ocena polegała na przypisaniu odpowiedniej liczby punktów i wag dla poszczególnych parametrów oraz interpretacji uzyskanych wyników w celu sprawdzenia możliwości samoistnej biodegradacji badanych zanieczyszczeń. Stwierdzono brak jednoznacznych dowodów na samoistną biodegradację (dehalogenację redukcyjną) TCE i PCE w wodach podziemnych w rejonie ujęcia Nowa Dęba. Wynika z tego, że w opisywanym przypadku oparcie remediacji wód podziemnych (i likwidacji zagrożenia dla ujęcia wody) na NA jest możliwe pod warunkiem zastosowania metod wspomagających biodegradację TCE i PCE.

**Słowa kluczowe:** samoistna biodegradacja, TCE, PCE, likwidacja zagrożenia, remediacja



Andrzej KOTOWSKI<sup>1</sup> and Bartosz KAŻMIERCZAK<sup>1</sup>

## DIMENSIONING OF THE SEWERAGE SYSTEM

### WYMIAROWANIE KANALIZACJI DESZCZOWEJ

**Abstract:** The paper presents verification of selected flow time methods in terms of usability for sewerage systems design and sizing on the example of a model municipal flat drainage area of 2 km<sup>2</sup>. Namely, the sewerage system network was sized using three methods, that is, MGN with Blaszczyk's formula, MGN with the precipitation model for Wrocław and MWO with the precipitation model for Wrocław, and then, the network functioning was verified for damming up on the area surface and flooding from drains using the hydrodynamic model SWMM 5.0. It was shown that the safe flow time method for sewerage system sizing is MWO using the criterion for the lack of damming up for the area and flooding from drains.

**Keywords:** sewer flooding, rain model, storm water management model

### Introduction

The sizing of sewerage systems or combined sewerage systems in Poland presents difficulties resulting from the lack of a reliable precipitation model. The most frequently used model of Blaszczyk from 1954 lowers calculation results for rainfall intensities by 40%, which has been shown on the example of precipitation measured at the IMGW meteorological station in Wrocław in the period of 1960-2009 [1]. This affects the design of drainage areas in Poland according to the latest European standard of PN-EN 752 related to permissible frequencies of sewerage system flooding. The safe design of sewerage systems aims at ensuring a proper standard of an area drainage, which is defined as a sewerage system adaptation to take forecast precipitation water flows with a frequency equal to the permissible - socially acceptable frequencies of flooding occurrences (Table 1).

The recommended design frequencies of rainfall and permissible flooding occurrence frequencies according to PN-EN 752:2008

Table 1

Design rainfall frequency [1 per C years]	The area drainage standard	Flooding occurrence frequency [1 per C years]
1 per 1	Out of town areas (rural)	1 per 10
1 per 2	Residential areas	1 per 20
1 per 5	City centers, service and industry area	1 per 30
1 per 10	Underground transportation facilities, underpasses, etc.	1 per 50

The application of hydrodynamic run-off models for the verification of sewerage system functioning requires a previous sizing of drainage systems by the so-called flow time methods. In such methods, the sewerage system or combined sewerage system sizing is based on a number of simplifying assumptions - constant block precipitation in a drainage basin, uniform steady flow in channels. Larger sewerage systems sized using these methods (in particular, with drainage basin areas of  $F > 2 \text{ km}^2$ ) are now recommended

<sup>1</sup> Institute of Environmental Engineering, Wrocław University of Technology, pl. Grunwaldzki 9, 50-377 Wrocław, phone 71 320 25 85, email: andrzej.kotowski@pwr.wroc.pl, bartosz.kazmierczak@pwr.wroc.pl

to be verified for hydraulic flow capacity based on calibrated simulation models to meet the requirements of PN-EN 752:2008.

### Initial assumptions and investigation methods

Partial drainage basins of the areas of 2.25 ha were assumed and the model basin of the dimensions of 750 x 2700 m and the total area of  $F = 202.5$  ha was proposed. The drainage basin consists of 90 modules - integrated partial drainage basins. It was assumed that the drainage basin for a residential area is located on a flat surface in Wrocław. Assuming the mean weighted coefficient of surface run-off from the drainage basin  $\psi = 0.25$ , its reduced area amounts to  $F_{cr} = 50.625$  ha. It has also been assumed that side channels being designed, to the number of 36 (Fig. 1), will have the length of 300 m each. The interceptor will have the total length of 2700 m. The channel wall coarseness is assumed at the level of  $n_k = 0.013 \text{ s/m}^{1/3}$ .

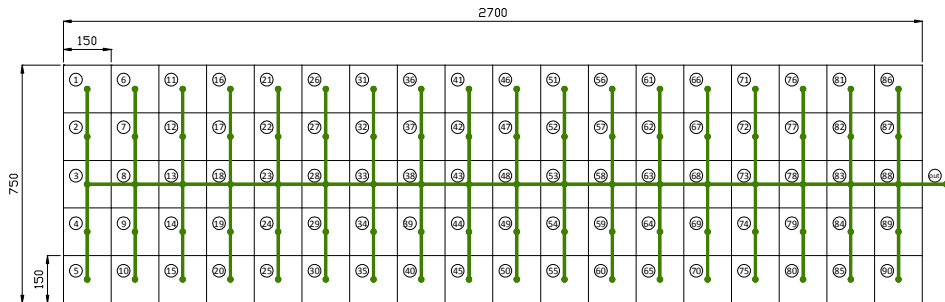

Fig. 1. The schematic diagram of the model drainage basin of the area of  $F = 202.5$  ha

In SWMM 5.0, a partial drainage basins is represented with a rectangle of a set area and width ( $W$ ). The stream of rainfall sewage flowing into a network design node is calculated using the model of a non-linear reservoir:

$$Q_m = W \frac{(d - d_p)^{5/3}}{n} i^{1/2}$$

where:  $Q_m$  - model run-off from a drainage basin [ $\text{m}^3/\text{s}$ ];  $W$  - hydrological width of a drainage basin [m];  $d$  - precipitation amount [m];  $d_p$  - surface retention height [m];  $n$  - Manning's surface roughness coefficient [ $\text{s}/\text{m}^{1/3}$ ];  $i$  - mean drainage basin area slope [-].

The following has been assumed for hydrological simulations: a substitute surface slope value  $i = 1\%$  a substitute roughness coefficient (for Manning's formula) for sealed drainage basin surfaces  $n = 0.02 \text{ s/m}^{1/3}$  and hydrological width of a drainage basin  $W = 300 \text{ m}$  [2-7].

### Sizing of example rainwater sewerage systems

When designing channel pits, 1.4 m has been assumed as a minimum soil covering for side channels and 1.9 m for an interceptor. Channels of a circular cross-section, arranged

with a minimum bottom slope selected from the formula  $1/D$  have been used. The hydrological and hydraulic computations have been conducted for three network sizing variants (three flow time methods):

- I. MGN with Blaszczyk's precipitation model.
- II. MGN with the maximum precipitation model for Wrocław.
- III. MWO with the maximum precipitation model for Wrocław.

In the MGN method used in Poland, it is assumed that the design volume flow of rainwater sewage ( $Q$ ) in the channel cross-section in question occurs with a certain delay in relation to the precipitation beginning moment, by the time necessary for: terrain concentration ( $t_k$ ), channel retention ( $t_r$ ) and flow in the channel ( $t_p$ ) - from the beginning to the design cross-section. Hence, the rainwater run-off time from the drainage basin is assumed to be equal to the dependable rainfall duration:  $t_{dm} = t_k + t_r + t_p$ . In any channel cross-section, the design volume flow  $Q$  [ $\text{dm}^3/\text{s}$ ] is written by the following formula:

$$Q = q(t_{dm}) \cdot F_{zr} = \frac{6.631 \sqrt[3]{H^2 C}}{t_{dm}^{2/3}} F_{zr}$$

where:  $q(t_{dm})$  - a rainfall intensity for a dependable duration according to Blaszczyk's formula [ $\text{dm}^3/(\text{s}\cdot\text{ha})$ ];  $H$  - a mean annual precipitation amount:  $H = 590$  mm for Wrocław [1];  $C$  - a design rainfall frequency [years];  $F_{zr}$  - a reduced rainfall drainage basin area [ha].

In the MWO method used in Germany, the time of sewage flow ( $t_p$ ) in a channel is assumed as dependable rainfall duration ( $t_d$ ). Thus, terrain and channel retention times are omitted mainly due to the network operational safety at precipitation occurrence frequencies  $C$  more seldom than the design frequencies. The rainwater run-offs determined in this manner are higher in comparison with values computed according to MGN [8]. The volume flow  $Q$  (in [ $\text{dm}^3/\text{s}$ ]) in MWO is calculated using the following formula

$$Q = q(t_d) \cdot F_{zr}$$

where  $q(t_d)$  - a rainfall intensity for a duration equal to a flow time ( $t_d = t_p$ ) [ $\text{dm}^3/(\text{s}\cdot\text{ha})$ ].

In the paper [1], the probabilistic model of maximum precipitations in the conditions of Wrocław has been formulated for the range of  $t_d \in [5; 4320]$  minutes and occurrence probability  $p = 1/C \in [1; 0.01]$  in the following form:

$$h(t_d) = -4.58 + 7.41 t_d^{0.242} + (97.11 t_d^{0.0222} - 98.68) (-\ln p)^{0.809}$$

where  $h(t_d)$  - the maximum rainfall amount (for the duration  $t_d$ ) [mm].

Table 2

The initial assumptions for sizing example networks of a rainwater sewerage system

Design variant	Design rainfall frequency $C$ [years]		Terrain concentration time $t_k$ [min]		Channel retention time $t_r$ [min]	Minimum dependable rainfall duration $t_d$ [min]
	side channels	interceptor	side channels	interceptor		
I.	1	2	10	5	$0.2 t_p$	10
II.	1	2	10	5	$0.2 t_p$	10
III.	2	2	0	0	0	15

The breakdown of initial assumptions for 3 different design variants of the rainwater sewerage system has been shown in the Table 2.

The cumulative breakdown of sizing results has been given in the Table 3.

Table 3

The sizing results of example sewerage networks [9]

Design variant	Run-off stream $Q$ [ $\text{m}^3/\text{s}$ ]	Design flow time [min]	Channels and interceptor dimensions [m]	Channels and interceptor burial depths [m bgl]	Network volume $V_K$ [ $\text{m}^3$ ]
I.	1.95	45.60	0.3-1.6	1.70-5.99	4849
II.	3.05	43.85	0.4-2.0	1.80-5.91	7234
III.	3.70	43.33	0.4-2.2	1.80-5.33	9825

Taking the design volume flow of rainwater sewage run-off from the I. variant of the sewerage system (Table 3):  $Q_{(I)} = 1.95 \text{ m}^3/\text{s}$  as the relative basis for comparisons (100%), then, the flow in the III. variant:  $Q_{(III)} = 3.70 \text{ m}^3/\text{s}$  is higher by as much as 90%.

### Creation the model precipitation of Euler's type II

The concept of the model precipitation is to yield a typical precipitation distribution of an intensity variable in time in a manner close to reality. An example of model precipitations is the Euler type II model, recommended for modeling of sewerage in Germany [10-12]. The model is based on the observation that the highest momentary rainfall intensity occurs at the end of the third part of its duration. The Euler model precipitation is recognized as corresponding to real measured series of annual storm rainfalls, which are typically not easily accessible for a designer.

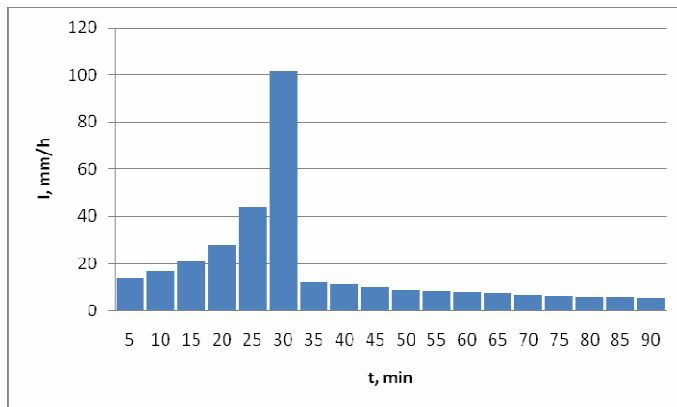

Fig. 2. The model precipitation of Euler type II for Wroclaw ( $C = 3$  years and  $t = 90$  min)

In order to verify the occurrence of damming up in channels, in example designer networks, the model drainage basin should be loaded with rainfall of the occurrence frequency of  $C = 3$  years and with duration twice as long as the network flow time according to the recommendations ATV-A118 [10]. Since the mean flow time in designed



model drainage basins is of the order of 45 min (Table 3), the model precipitation with the duration of  $t = 90$  min (Fig. 2) has been developed based on the formula for the maximum precipitation amount in Wrocław [1].

The model precipitation developed for the conditions of Wrocław for  $t = 90$  min and  $C = 3$  years ( $p = 0.33$ ) is characterized by the maximum intensity of 101.71 mm/h, occurring between the 25<sup>th</sup> and 30<sup>th</sup> minute. The mean precipitation intensity amounts to 17.83 mm/h, which corresponds to 26.75 mm of the precipitation height.

### Modeling the operation of example sewerage system

In order to verify the hydraulic flow capacity - sized in the 3 variants - of the rainfall sewerage system, the drainage basin has been loaded with the model precipitation of Euler type II for the conditions of Wrocław. From the total precipitation amount (26.75 mm), its fourth part ( $\psi = 0.25$ ) has been transformed into the surface flow and reached the sewerage system. As a result of hydrodynamic simulations carried out, the information on volume flows and fills in specific sewerage sections in the time of the model precipitation duration was obtained. The interceptor profile in a selected precipitation duration time (the 31<sup>st</sup> minute) for the sewerage system sized in the I. variant has been shown in the Figure 3.

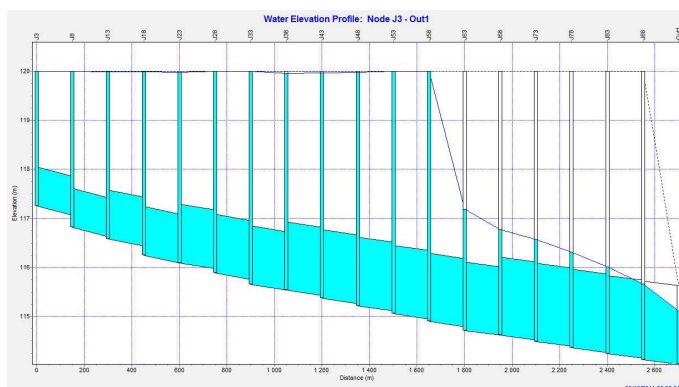

Fig. 3. The interceptor profile in the 31<sup>st</sup> minute of the precipitation duration modeled in the I. variant

The rainwater sewerage system designed in this variant does not have appropriate hydraulic flow capacity to discharge modeled rainwater run-offs without damming up to the ground level. The damming ups of a few meters - including to the ground surface and flooding - occur in most interceptor design nodes. The total sewage volume, which was not contained or flowed out of the network amounts to 1291 m<sup>3</sup> during the model precipitations. The flooding were observed in the total of 71 design nodes. In the I. variant of the sized sewerage system, the maximum model volume flow in the last interceptor section amounted to  $Q_{m(l)} = 5.16$  m<sup>3</sup>/s.

In order to verify the hydraulic flow capacity of the sewerage system designed in the II. variant, the drainage basin has been loaded with the model precipitation similarly to the I. variant. The inceptor profile with fills in the selected time of the precipitation duration (the 33<sup>rd</sup> minute) has been shown in the Figure 4.

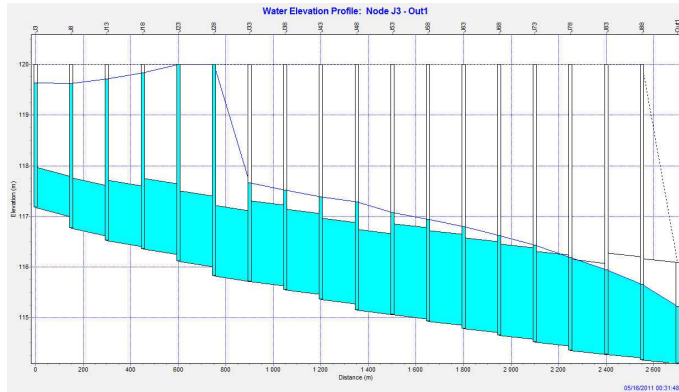

Fig. 4. The interceptor profile in the 33<sup>rd</sup> minute of the model precipitation duration in the II. variant

As it can be seen in the Figure 4, the damming ups in the beginning interceptor sections - in nodes J23 and J28, in the presented time moment of the simulation, reach the ground level (flooding). The middle and partially ending interceptor sections operate under small pressure. In case of the beginning side channels, we also have damming ups to the ground level, however for the further side channels, where the interceptor is buried considerably deeper, the damming ups to the ground level do not occur. The total sewage volume, which flowed out from the sewerage system during the model rainfall, amounts to 20 m<sup>3</sup> only. All in all, the flooding was observed in 12 nodes only. The maximum model volume flow reached  $Q_{m(II)} = 6.11 \text{ m}^3/\text{s}$ .

In order to verify the hydraulic flow capacity of the sewerage system designed in the III. variant, it has also been loaded with the model precipitation of Euler type II. The interceptor profile with fills in the selected time of the precipitation duration (the 34<sup>th</sup> minute) has been shown in the Figure 5.

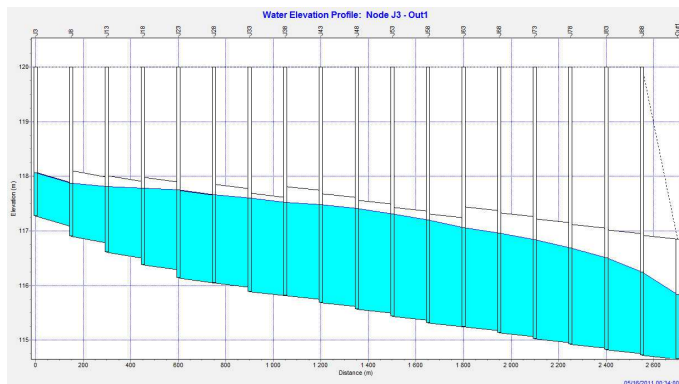

Fig. 5. The interceptor profile in the 34<sup>th</sup> minute of the model precipitation duration in the III. variant

As it follows from the Figure 5, practically the entire interceptor operates with a free sewage table during the set model rainfall, except for the interceptor section J23-J28

operating with a several-centimeter damming up above the channel vaulting. Damming up to the ground level are also absent in the case of all side channels - the lack of flooding from channels. Only damming up of a several dozen centimeters in relation to vaults occur on the first two sections, the two side channels. The maximum model volume flow (in the III. variant) on the last interceptor section reached  $Q_{m(III)} = 6.95 \text{ m}^3/\text{s}$ . The cumulative breakdown of the operation analysis of the model sewerage systems (sized in the three variants) has been shown in the Table 4.

Table 4

The results of operation modeling of example sewerage systems

Design variant	Model flow $Q_m$ [ $\text{m}^3/\text{s}$ ]	Number of flooding	Volume of flooding [ $\text{m}^3$ ]	Run-off and network emptying time [hours]
I	5.16	71	1291	4.7
II	6.11	12	20	5.1
III	6.95	0	0	5.3

The maximum values of the simulated volume flows rise with the increase in the network flowability, that is, the channel diameters and network volume (Table 4): from  $Q_{m(I)} = 5.16 \text{ m}^3/\text{s}$  - in the I. variant (with numerous flooding) to  $Q_{m(III)} = 6.95 \text{ m}^3/\text{s}$  (without flooding). The high volume of the storm channels in the III. variant of the sewerage system sizing  $V_{K(III)} = 9825 \text{ m}^3$  is then a considerable buffer in relation to the water run-off volume of the model precipitation from the drainage basin.

## Summary and conclusions

The investigations described in this paper have been carried out to verify the selected flow time methods for usability in the safe designing of sewerage systems. The verification was conducted on the example of the model drainage basin located on the flat land in the hydrological conditions of Wrocław. To simulate the functioning of sewerage system sized in this manner, the application SWMM 5.0 was deployed, in which the precipitation model of Euler type II was assumed as the precipitation load, while damming up and flooding were assumed as the criterion of the correct network operation.

The analyses carried out have unequivocally shown that the safe sewerage system sizing method is the MWO with the maximum precipitation model for Wrocław due to the lack of damming up to the ground level and flooding from the sewerage system. Blaszczyk's formula and MGN in general considerably underrates the storm sewage volume flow necessary for sewerage system sizing, causing in consequence numerous damming up to the ground level and flooding (Table 4). The number of damming ups and flooding volumes from the sewerage system sized in the I. variant amount to: 71 and  $1291 \text{ m}^3$ , respectively. The attempt to substitute Blaszczyk's formula in MGN with the new maximum precipitation formula for Wrocław (in the II. variant) has also failed to give satisfying results - the number of damming ups and flooding volume have only decreased (12 and  $20 \text{ m}^3$ , respectively). The third rainwater sewerage system sizing variant - according to MWO with the maximum precipitation model for Wrocław - ensures the safe network sizing results for the model drainage basin in the conditions of Wrocław - the lack of damming ups to the ground level and flooding (Table 4).

When the model precipitation has decreased, the rainwater run-off time, and mainly channel emptying time keeps lasting for a few hours from the moment the precipitation ends - the longer the time, the bigger the channel diameters and lower required bottom slopes. In this time, the sewerage system (sized for  $C = 2$  years at  $t_d = t_p = 45$  minutes) is not fully ready to take the rainfall of similar intensity and duration as the model precipitation ( $C = 3$  years and  $t_d = 2t_p = 90$  minutes), since channels are still partially filled. Thus, flooding from channels is inevitable, even when using correct flow time methods for the sizing of drainage networks, and then for the verification of their operation in hydrodynamic modeling due to the stochastic nature of rainfall. Thus, this breaks down to the limiting of damming up and flooding occurrence probability, which can only be obtained in safely sized sewerage systems.

## References

- [1] Kotowski A, Kaźmierczak B, Dancewicz A. Precipitation modeling for sewerage measuring. Studies in Engineering No. 68, Warszawa: The Publishing House of the Civil Engineering Committee the Polish Academy of Science; 2010.
- [2] Rossman LA. Storm Water Management Model. User's Manual. Version 5.0. Cincinnati: United States Environmental Protection Agency; 2010.
- [3] Kotowski A. The Principles of Safe Dimensioning of Sewage Systems. Warszawa; Seidel-Przywecki; 2011.
- [4] Kaźmierczak B, Kotowski A. Depth-Duration-Frequency rainfall model for dimensioning and modelling of Wrocław drainage systems. Environ Protect Eng. 2012;38(4):127-138. DOI: 10.5277/EPE120411.
- [5] Guo YP. Hydrologic design of urban flood control detention ponds. J Hydrol Eng. 2001;6(6):472-479. DOI: 10.1061/(ASCE)1084-0699.
- [6] Mignot E, Paquier A, Haider S. Modeling floods in a dense urban area using 2D shallow water equations. J of Hydrology. 2006;327(1-2):186-199. DOI: 10.1016/j.jhydrol.2005.11.026.
- [7] Das A. Parameter estimation for flow in open-channel networks. J Irrig Drainage Eng. 2004;130(2):160-165. DOI: 10.1061/(ASCE)0733-9437.
- [8] Kotowski A. Of the need to adapt the dimensioning rules of sewer systems in Poland to the requirements of the standard PN-EN 752 and recommendations of the European Committee for Standardization. Gaz, Woda i Techn Sanitar. 2006;6:20-26.
- [9] Kaźmierczak B. Simulation investigations of storm water overflows and separators operation in unstable flow conditions to aid drainage system design. The Institute of Environmental Engineering of the Wrocław University of Technology, The doctor's thesis (Promoter: Kotowski A.). Wrocław: 2011.
- [10] Arbeitsblatt DWA-A118: Hydraulische Bemessung und Nachweis von Entwässerungs-systemen. Hennef: DWA; 2006.
- [11] Schmitt TG. Kommentar zum Arbeitsblatt A 118 "Hydraulische Bemessung und Nachweis von Entwässerungssystemen". Hennef: DWA; 2000.
- [12] Schmitt TG, Thomas M. Rechnerischer Nachweis der Überstauhäufigkeit auf der Basis von Modellregen und Starkregenserien. KA - Wasserwirtschaft, Abwasser, Abfall. 2000;47(1):63-69.

## WYMIAROWANIE KANALIZACJI DESZCZOWEJ

Instytut Inżynierii Ochrony Środowiska, Politechnika Wrocławska

**Abstrakt:** W pracy symulowano działanie kanalizacji deszczowej zwymiarowanej trzema metodami czasu przepływu, tj.: MGN z wzorem Błaszczyka, MGN z wzorem opadów dla Wrocławia i MWO z wzorem opadów dla Wrocławia, dla modelowej zlewni miejskiej o powierzchni 2 km<sup>2</sup> w terenie płaskim. Do symulacji hydrodynamicznych działania systemów kanalizacyjnych wybrano program SWMM 5.0 (Storm Water Management Model), opracowany przez Amerykańską Agencję Ochrony Środowiska (US EPA). Wskazano na bezpieczną metodę wymiarowania kanalizacji deszczowej (MWO) przy kryterium braku wylewów z kanałów.

**Słowa kluczowe:** wylania z kanalizacji, opad modelowy, model zarządzania wodami opadowymi

Artur KUBICZEK<sup>1</sup> and Władysław KAMIŃSKI<sup>1</sup>

## IONIC LIQUIDS FOR THE EXTRACTION OF *n*-BUTANOL FROM AQUEOUS SOLUTIONS

### CIECZE JONOWE W EKSTRAKCYI *n*-BUTANOLU Z ROZTWORÓW WODNYCH

**Abstract:** The article describes the extraction of *n*-butanol from four-component aqueous solutions, also containing acetone and ethanol. All of these three chemicals are the main constituents of the so-called fermentation broth - a product of ABE (*Acetone-Butanol-Ethanol*) fermentation process. Nowadays, ABE fermentation, which is one of the oldest butanol production techniques, seems to be a viable alternative to petrochemical methods that have so far dominated the industry. Such considerations are driven by the steady depletion of fossil fuels, and thus, worldwide tendencies to use renewable resources instead, but also by the popularization of clean production and green chemistry principles. The physicochemical properties of biobutanol are very similar to that of gasoline and diesel fuel. Therefore, there exists a real potential for its widespread use as a fuel additive or even for a direct application in internal combustion engines. For that reason, the effective separation of biochemically derived butanol may have a great impact on fuel production technology, which is by far crude oil oriented. The main challenges of applying traditional solvents in liquid-liquid extraction are their toxicity and usually high volatility that prevents an economically justified partitioning of the extract components. Hence there arises a growing interest in non-volatile, thermally stable and water immiscible ionic liquids. Properties of these new 'designer solvents' have not been fully recognized yet, but the full range of their possible applications may appear as unlimited. Phase separation research has been made in five-component systems of water, acetone, butanol, ethanol and ionic liquid. Two different ionic liquids have been used: 1-hexyl-3-methylimidazolium hexafluorophosphate [Hmim][PF<sub>6</sub>] and 1-butyl-3-methylimidazolium bis(trifluoromethylsulfonyl)imide [Bmim][Tf<sub>2</sub>N]. Experimental results confirm highly efficient separation of *n*-butanol from aqueous solutions when volumes of both liquid phases are approximately equal.

**Keywords:** liquid-liquid extraction, ionic liquids, biobutanol, renewable resources

### Introduction

Butanol is a chemical capable of numerous industrial and non-industrial applications, but, first and foremost, it should be considered as a viable alternative to gasoline. It displays favourable combustion characteristics and, as a fuel additive, it is superior to widely used ethanol in many aspects (*eg.* lower volatility, higher energy content, better miscibility with diesel fuel and gasoline). From a technical standpoint, appropriate modifications in the existing combustion engines are also possible [1]. Comparison of butanol with other fuels (according to [2, 3]) is shown in Table 1.

Table 1

Properties of fuels

	Butanol	Gasoline	Diesel fuel	Ethanol	Methanol
Energy density [MJ/dm <sup>3</sup> ]	29.2	32.0	35.9	19.6	16.0
Air-fuel ratio (AFR)	11.2	14.7	14.6	9.0	6.5
Heat of vaporization [MJ/kg]	0.43	0.36	0.23	0.92	1.20
Research Octane Number (RON)	96	91-99	-	129	136
Motor Octane Number (MON)	78	81-89	-	102	104

<sup>1</sup> Department of Process Thermodynamics, Faculty of Process and Environmental Engineering, Lodz University of Technology, ul. Wolczanska 213, 93-005 Łódź, phone 42 631 37 00, email: arturkubiczek@wp.pl

Since the 1950s butanol has been produced almost solely from fossil fuels. However, one of the oldest industrial biochemical techniques of butanol production, which has been superseded by crude oil processing, is the ABE fermentation exploiting anaerobic *Clostridium* bacteria. In view of the steady depletion of hydrocarbon deposits and recent proecological regulations this method is certainly worth looking into again.

Of all the applicable bacterial species, the genetically modified strain *Clostridium beijerinckii* is the most butanol selective - the total concentration of products (*ie* acetone, butanol and ethanol) obtained in the fermentation broth ranges between 15-26 g/dm<sup>3</sup> depending on the substrates, with butanol yield approaching 19-20 g/dm<sup>3</sup> [4].

Separation of biobutanol from the fermentation broth poses a complex technical problem. First of all, it must be carried out in a continuous manner, because an excessive concentration of products inhibits the bacteria [5]. Secondly, the applied technique should not be demanding in terms of energy and costs. Finally, classical extraction solvents might be of practical use, but they are mostly toxic and volatile, in other words, not environmentally friendly.

A variety of methods have been proposed for the stated purpose, such as gas stripping, adsorption, *liquid-liquid extraction* (LLE), pervaporation and membrane solvent extraction. However, liquid-liquid extraction, along with pervaporation, appears to be the most suitable techniques [6]. Therefore, ionic liquids, which recently gained some notable recognition in science and industry, may turn out to be highly appropriate for the recovery of biobutanol.

*Ionic liquids* (ILs) are liquid substances composed solely of ions (in a general sense, molten salts). However, most salts melt in high temperatures. Therefore, contemporary ionic liquids are salts whose melting point is lower than 100°C. There are also salts melting in temperatures lower than 20°C and they are called *room-temperature ionic liquids* (RTILs). Ionic liquids are often described as *designer solvents*. Because of practically unlimited number of combinations between anions and cations, their properties may be “adjusted” to suit certain process requirements [7, 8].

The main attributes of ionic liquids making them useful in separation of mixtures are very low volatility and wide liquid range (often exceeding 200°C) [9, 10], which may allow their relatively easy regeneration (*via* low pressure distillation) and recirculation. A lack of toxic fumes is the additional benefit.

It is of fundamental significance that the ionic liquid employed as the extracting solvent should be hydrophobic, *ie*, immiscible with the aqueous phase. It has been noted that some of the ILs are water-miscible while others are not, even if their chemical structures are not much different [11]. Nevertheless, hydrophobicity is the main quality determining the choice of ILs for this study.

## Materials and methods

The study of phase equilibrium was conducted in five-component two-phase systems of water, acetone, butanol, ethanol and ionic liquid, corresponding to the fermentation broth composition. Acetone, butanol and ethanol used in the experiments were of at least 99% purity (*CHEMPUR, Poland*). Two hydrophobic ionic liquids, 1-hexyl-3-methylimidazolium hexafluorophosphate [Hmim][PF<sub>6</sub>] and 1-butyl-3-methylimidazolium

bis(trifluoromethylsulphonyl)imide [Bmim][Tf<sub>2</sub>N] (*Io•Li•Tec, Germany*), whose chemical structures are shown in Figures 1 and 2, were applied as extractants.

The experiments were carried out with four-component feed solutions containing water, acetone, *n*-butanol and ethanol. Mass fractions of acetone, butanol and ethanol varied between 0 and 6%. Volumes of solutions ranged from 0.5 to 2.0 cm<sup>3</sup>. Approximately 1.0 cm<sup>3</sup> of ionic liquid was added to each feed solution. Then the mixtures were placed in a thermostated water bath and shaken for about 1.5-2.0 hrs. At the end of that period they were centrifuged to expedite phase separation (Fig. 3).

The extraction was conducted at temperatures of 10, 30 and 50°C.

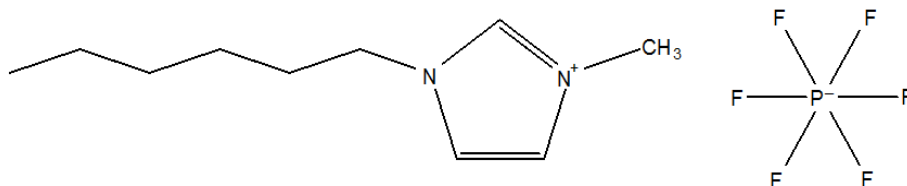

Fig. 1. Structural formula of 1-hexyl-3-methylimidazolium hexafluorophosphate

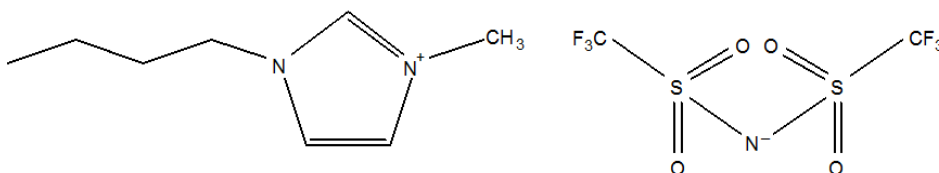

Fig. 2. Structural formula of 1-butyl-3-methylimidazolium bis(trifluoromethylsulfonyl)imide

Concentrations of acetone, butanol and ethanol in the raffinate (water-rich phase) were measured with a gas chromatograph (*TraceGC ThermoFinnigan* with *Quadrex Corp.* column) using internal standard (methanol).

Water content in the extract (IL-rich phase) was determined by Karl-Fischer titration (*Mettler Toledo T70 Titrator*).

Measurements showed that the presence of solvents, especially butanol and acetone, as well as temperature augmented solubility of water in both ionic liquids. Likewise, solubility of ionic liquids in water was enhanced by the same factors.

ILs content in the raffinate was calculated based on a separate set of experiments, in which all mixture components, but ionic liquid, were evaporated.

Preliminary tests revealed that both ionic liquids were practically non-volatile at the boiling point of the highest boiling component of the mixture, in this case butanol (BP = 116-118°C). Therefore, ionic liquid was the only component that did not evaporate from the solution of known mass and content.

Complete compositions of both phases were calculated on the basis of the above mentioned measurements.

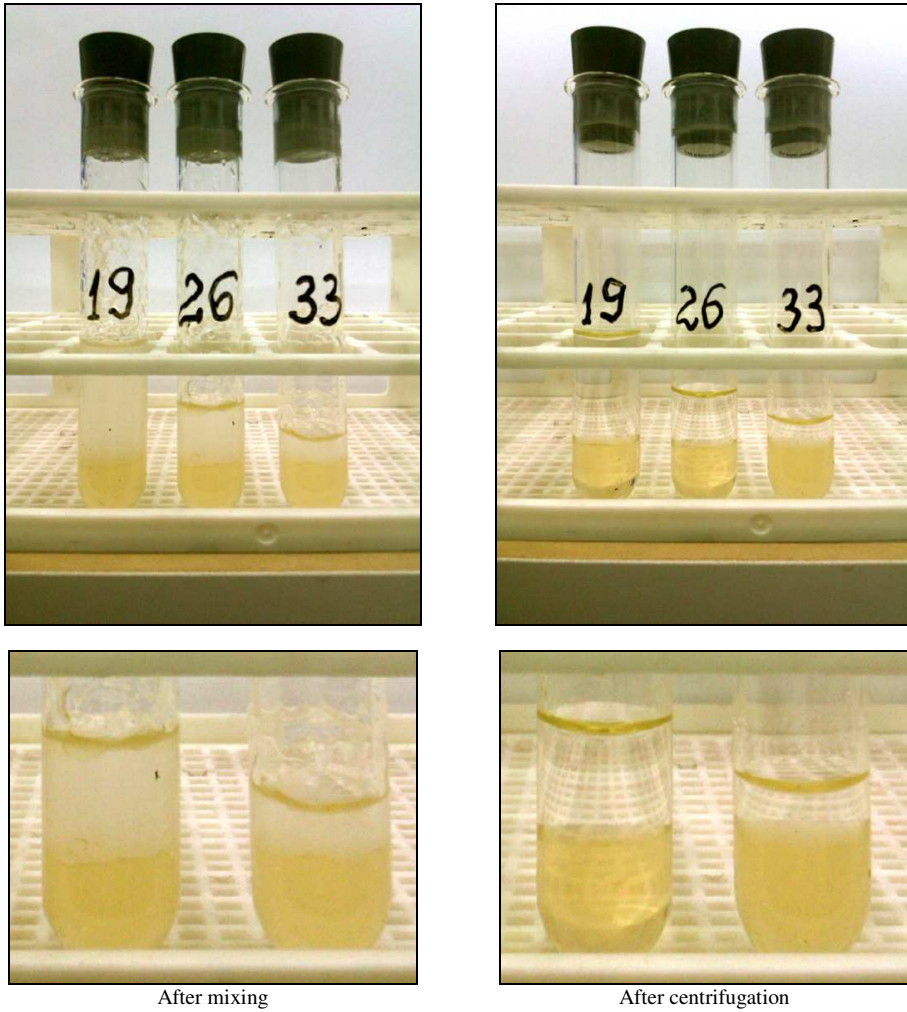

Fig. 3. Mixtures containing water, 1-hexyl-3-methylimidazolium hexafluorophosphate, acetone, butanol and ethanol

## Results

Phase equilibrium of five-component systems has been described by distribution coefficients, extraction efficiency and selectivity defined as follows:

- Extraction efficiency

$$\eta = \left( 1 - \frac{C_W}{C_F} \right) \cdot 100 \quad (1)$$

where:  $C_F$  - concentration of a component in the feed solution (aqueous phase) [g/g],  
 $C_W$  - concentration of a component in the raffinate (water-rich phase) after separation [g/g].



- Distribution coefficient

$$\alpha = \frac{C_{IL}}{C_W} \quad (2)$$

where:  $C_{IL}$  - concentration of a component (also water) in the IL-rich phase after separation [g/g],  $C_W$  - concentration of a component (also water) in the water-rich phase after separation [g/g].

- Selectivity

$$\beta = \frac{\alpha}{\alpha_w} \quad (3)$$

where:  $\alpha$  - distribution coefficient of a component,  $\alpha_w$  - distribution coefficient of water.

The results are shown in Tables 2-5, where  $m_{IL}/m_W$  is a mean ionic liquid and water mass ratio for a given set of experiments.

Density of ionic liquid is greater than density of water. Therefore, assuming approximately equal volumes of both phases, the IL-rich phase is heavier. The experiments have been done with ca 0.5, 1.0 and 2.0 cm<sup>3</sup> volumes of feed solutions.

Table 2

Distribution coefficients of acetone, butanol, ethanol and water after extraction by [Hmim][PF<sub>6</sub>]

Temperature [°C]	$m_{IL}/m_W$	$\alpha_A$	$\alpha_B$	$\alpha_E$	$\alpha_w$
10.0	0.609	1.043	1.089	0.183	0.024
10.0	1.201	0.917	0.889	0.125	0.023
10.0	2.575	0.998	0.912	0.111	0.020
30.0	0.625	1.122	1.371	0.200	0.029
30.0	1.221	1.110	1.242	0.162	0.027
30.0	2.478	1.081	1.178	0.169	0.024
50.0	0.601	1.269	1.810	0.236	0.032
50.0	1.206	1.176	1.546	0.214	0.031
50.0	2.475	1.205	1.492	0.191	0.028

Table 3

Distribution coefficients of acetone, butanol, ethanol and water after extraction by [Bmim][Tf<sub>2</sub>N]

Temperature [°C]	$m_{IL}/m_W$	$\alpha_A$	$\alpha_B$	$\alpha_E$	$\alpha_w$
10.0	0.789	0.907	1.153	0.146	0.024
10.0	1.574	1.064	1.329	0.155	0.023
10.0	3.140	0.934	1.247	0.123	0.019
30.0	0.792	1.124	1.695	0.215	0.028
30.0	1.577	1.037	1.516	0.192	0.026
30.0	3.169	1.040	1.464	0.169	0.024
50.0	0.789	1.167	2.054	0.256	0.032
50.0	1.578	1.097	1.869	0.228	0.031
50.0	3.165	1.249	1.970	0.240	0.028

Table 4

Selectivity and efficiency of extraction (in [%]) of acetone, butanol and ethanol by [Hmim][PF<sub>6</sub>]

Temperature [°C]	$m_{II}/m_W$	$\beta_A$	$\beta_B$	$\beta_E$	$\eta_A$	$\eta_B$	$\eta_E$
10.0	0.609	44.52	46.15	7.28	36.7	37.8	6.8
10.0	1.201	40.15	38.72	5.36	49.7	48.7	7.8
10.0	2.575	50.52	46.97	5.42	69.3	67.0	14.0
30.0	0.625	39.17	44.98	6.98	38.8	43.9	7.4
30.0	1.221	40.97	46.98	6.00	54.6	57.9	11.1
30.0	2.478	45.20	46.46	7.10	70.2	72.4	22.1
50.0	0.601	40.61	57.67	7.35	41.4	50.7	9.1
50.0	1.206	38.34	50.07	6.91	56.4	63.2	15.2
50.0	2.475	43.76	54.28	6.88	72.8	76.9	24.5

Table 5

Selectivity and efficiency of extraction (in [%]) of acetone, butanol and ethanol by [Bmim][Tf<sub>2</sub>N]

Temperature [°C]	$m_{II}/m_W$	$\beta_A$	$\beta_B$	$\beta_E$	$\eta_A$	$\eta_B$	$\eta_E$
10.0	0.789	38.87	48.90	6.09	39.1	45.4	6.6
10.0	1.574	47.42	59.36	6.91	60.2	65.7	13.5
10.0	3.140	48.86	66.08	6.36	72.5	78.0	20.3
30.0	0.792	39.44	59.29	7.55	44.7	55.5	10.4
30.0	1.577	39.05	56.51	7.26	59.6	68.7	17.3
30.0	3.169	43.80	61.03	7.07	74.7	80.9	27.2
50.0	0.789	36.54	64.06	7.92	45.7	60.4	12.6
50.0	1.578	36.04	61.14	7.45	60.8	73.2	20.5
50.0	3.165	44.99	71.47	8.63	78.1	85.2	36.3

## Conclusions

From the results presented it is evident that there are two main factors having a decisive influence on the extraction efficiency, namely temperature and the amount of extractant. The highest efficiencies for both ILs studied, ca 77% and 85% respectively, were reached at 50°C with volumes of ILs approximately two-fold greater than volumes of feed solutions. Distribution coefficients for all substances essentially grow as temperature rises, but their variations resulting from different  $m_{II}/m_W$  ratios at constant temperatures cannot be explained at this stage of the study. Also, an increase in temperature appears to favour separation of butanol over acetone and ethanol, which is reflected by growing selectivity (not so obvious for the other two substances).

Generally speaking, both ionic liquids, when used in quantities comparable with the amount of feed solution, ensure about 50-65% efficiency of extraction at room temperature for both acetone and butanol, which is of some significance from an energy consumption standpoint. At the same time, ethanol gets separated rather poorly.

## References

- [1] Kamiński W, Tomczak E, Górak A. Biobutanol - production and purification methods. *Ecol Chem Eng S.* 2011;18(1):31-37.
- [2] Lee SY, et al. Fermentative butanol production by Clostridia. *Biotechnol Bioeng.* 2008;101(2):209-228. DOI: 10.1002/bit.22003.
- [3] www.afdc.energy.gov.
- [4] Ezeji TC, Qureshi N, Blaschek HP. Butanol Fermentation Research: Upstream and Downstream Manipulations. *The Chemical Record.* 2004;4:305-314. DOI: 10.1002/tcr.20023.

- [5] Simoni LD, Chapeaux A, Brennecke JF, Stadtherr MA. Extraction of biofuels and biofeedstocks from aqueous solutions using ionic liquids. *Computers and Chemical Engineering*. 2010;34:1406-1412. DOI: 10.1016/j.compchemeng.2010.02.020.
- [6] Ha SH et al. Butanol recovery from aqueous solution into ionic liquids by liquid-liquid extraction. *Process Biochemistry*. 2010;45:1899-1903. DOI: 10.1016/j.procbio.2010.03.030.
- [7] Earle MJ, Seddon KR. Ionic Liquids. Green solvents for the future. *Pure and Applied Chemistry*. 2000;72(7):1391-1398. DOI: 10.1351/pac200072071391.
- [8] Electrochemical aspects of ionic liquids. Hiroyuki Ohno, editor. Hoboken, New Jersey: John Wiley & Sons, Inc; 2005. DOI: 10.1002/0471762512.
- [9] Fredlake CP, Crosthwaite JM, Hert DG, Aki SNVK, Brennecke JF. Thermophysical properties of imidazolium-based ionic liquids. *J. Chemical and Engineering Data*. 2004;49:954-964. DOI: 10.1021/je034261a.
- [10] Johnson KE. What's an ionic liquid? *The Electrochemical Society Interface*. 2007;Spring:38-41.
- [11] Klähn M, Stüber C, Seduraman A, Wu P. What determines the miscibility of ionic liquids with water? Identification of the underlying factors to enable a straightforward prediction. *J Physical Chem B*. 2010;114:2856-2868. DOI: 10.1021/jp1000557.

## CIECZE JONOWE W EKSTRAKCYJ *n*-BUTANOLU Z ROZTWORÓW WODNYCH

Katedra Termodynamiki Procesowej, Wydział Inżynierii Procesowej  
i Ochrony Środowiska, Politechnika Łódzka

**Abstrakt:** Przedmiotem artykułu jest proces ekstrakcji *n*-butanolu z czteroskładnikowych roztworów wodnych zawierających ponadto aceton i etanol. Wymienione substancje są głównymi składnikami tzw. brzeczki fermentacyjnej stanowiącej produkt fermentacji ABE (acetonowo-butanolowo-etanolowej). Fermentacja ABE, jako jedna z najstarszych metod uzyskiwania biobutanolu stosowanych na skalę przemysłową, jest obecnie rozważana jako alternatywa dla dominujących w przemyśle procesów petrochemicznych. Znacząco przyczynia się do tego perspektywa wyczerpania dostępnych zapasów paliw kopalnych, jak również podejmowane na szeroką skalę próby wdrażania zasad czystej produkcji i korzystania z odnawialnych źródeł energii. Z uwagi na bardzo korzystne właściwości fizykochemiczne istnieją realne możliwości bezpośredniego zastosowania biobutanolu w silnikach spalinowych bądź wykorzystania go jako dodatku do oleju napędowego i benzyny. Skuteczna separacja biobutanolu pozyskiwanego za pomocą metod biochemicznych może mieć zatem ogromny wpływ na rozwój technologii produkcji paliw płynnych. Problemem przy stosowaniu klasycznych rozpuszczalników w ekstrakcji cieczy-ciecz jest często ich toksyczność, jak również wysoka lotność uniemożliwiająca opłacalny ekonomicznie rozdział ekstraktu. Dlatego też w kręgu zainteresowania pojawiają się niskolotne i stabilne termicznie ciecze jonowe nierozpuszczalne w roztworach wodnych. Właściwości cieczy jonowych jako substancji stosunkowo nowych nie są jeszcze dokładnie poznane, jednak z uwagi na szeroki wachlarz potencjalnych zastosowań budzą one coraz większe zainteresowanie, a możliwości ich "projektowania" mogą wydawać się nieograniczone. Przeprowadzono badania równowagi ekstrakcyjnej w układach zawierających wodę, aceton, butanol, etanol i ciecz jonową. Wykorzystano w tym celu dwie ciecze jonowe: heksafluorofosforan 1-heksylo-3-metyloimidazolu oraz bis(trifluorometylosulfonylo)imid 1-butylo-3-metyloimidazolu. Wyniki eksperymentów potwierdzają wysoką skuteczność procesu ekstrakcji *n*-butanolu przy zbliżonych objętościach roztworu surowego i ekstrahenta.

**Słowa kluczowe:** ekstrakcja cieczy-ciecz, ciecze jonowe, biobutanol, odnawialne źródła energii



Małgorzata MUSIALIK<sup>1</sup>, Marcin M. CHRZANOWSKI<sup>1</sup>, Irmina BUCZEK<sup>1</sup>  
Enzo B. ARÈVALO-GARCIA<sup>1</sup> and Barbara OSTROWSKA<sup>1</sup>

## ELEMENTS OF ENVIRONMENTAL EDUCATION IN THE NEW POLISH CURRICULUM FOR TEACHING CHEMISTRY AND SELECTED CHEMISTRY TEXTBOOKS AT ISCED 2 AND ISCED 3 LEVEL

### ELEMENTY EDUKACJI PROŚRODOWISKOWEJ W NOWEJ PODSTAWIE PROGRAMOWEJ PRZEDMIOTU CHEMIA ORAZ W WYBRANYCH PODRĘCZNIKACH DO NAUCZANIA CHEMII DLA III I IV ETAPU KSZTAŁCENIA

**Abstract:** In 2009 the Ministry of National Education introduced a new core curriculum for general education in Poland which completely transformed environmental education at ISCED 2 (Polish: *gimnazjum*, junior high school) and ISCED 3 (post-*gimnazjum*, senior high schools of different types) stages. Considering the immense impact of chemical substances on the state of global nature, the curriculum for chemistry plays a pivotal role in the development of environmental knowledge and pro-environmental attitudes among students in Polish schools. There is no doubts that not only are chemistry textbooks the basic source of scientific knowledge for students, but they also inspire teachers during class preparation. The educational reform created a need for updating chemistry textbooks according to new core curriculum. The aim of this work was to investigate the coherence between elements of environmental education required by core curriculum and the depiction of these issues proposed in textbooks. Textbooks of major Polish educational publishers for junior and senior secondary schools at basic level were analyzed. The results of this study show that all examined textbooks are coherent with environmental issues included in the program fundamentals, but they also give additional pieces of information when needed, even when such content is not precisely defined in the core curriculum (eg organic chemical waste problems). The comparison of selected textbooks provided information on the present state of education reform implementation and on what could be improved or clarified in the new core curriculum regarding environmental problems.

**Keywords:** environmental education, pro-environmental attitude, new core curriculum, chemistry textbooks

### Introduction

The Science Section of the Educational Research Institute participates in a project called *Teaching quality and school effectiveness - building tools for research - Passionate about Education* which main goals are: providing teachers with educational tools and novel solutions to evaluate students' thinking skills, interdisciplinary research in Poland and other countries, reports on the state of education in Poland and reports on the implementation of New Science Core Curriculum [1] into teaching programs and school textbooks.

Environmental and ecological content is present in the new core curriculum of all traditional subjects but biology, geography and *natural science* (*przyroda*) are considered to be the most important in the scope of environmental education in Polish schools [2], and the role of chemistry in the environmental education seems to be overlooked. Since chemical industry and chemical substances used in everyday life are major sources of pollutants of air, water and soil, and they contribute immensely to such harmful processes

<sup>1</sup> Science Section, Educational Research Institute, ul. Górczewska 8, 01-180 Warsaw, phone 22 241 71 12, email: m.musialik@ibe.edu.pl

as the formation of the ozone hole, acid rains and greenhouse effect, chemistry teaching should be perceived as crucial in the development of environmental knowledge and pro-environmental attitudes among students. Teaching chemistry bases on the core curriculum, textbooks approved by The Ministry of Education and teaching programs approved by school headmasters (in consultation with teachers and school board). The amount of time which can be spent on the realization of the program is restricted, therefore teachers do not have much time for discussing issues in details. Students who wish to broaden or consolidate their scientific knowledge have to reach for chemistry textbooks, thus the importance of this source of learning cannot be omitted. The new science curriculum forced publishers to update chemistry textbooks. Noteworthy is that new textbooks can be also extremely helpful for teachers who need to prepare their classes in accordance with the new core curriculum.

The main aim of this paper was to investigate the environmental issues included in the new core curriculum for subject chemistry and their implementation in various chemistry textbooks for junior high school (ISCED 2) and 1<sup>st</sup> grade of senior high school level (ISCED 3).

### **Environmental education in Polish schools**

In 1987 the Brundtland Report of the World Commission on Environment and Development defined the term “sustainable development” as a process whose goal is to satisfy the growth aspirations of the present generation in such a way as to enable the future generations to also satisfy their aspirations [3]. The authors of this report specified three areas important for planning an effective strategy of achieving sustainable development: i) environmental protection and rational exploitation of natural resources (*eg* minimizing environmental pollution, protection of endangered plant and animal species, promotion of renewable energy sources); ii) economic growth and fair distribution of its benefits (*eg* changing ineffective models of production and consumption); iii) social growth (*eg* fighting poverty, widening access to education and healthcare). These goals cannot be achieved without providing extensive environmental education [4, 5] and pro-environmental attitude [6].

The previous educational system paid less attention to ecological issues, and as a consequence Polish society had relatively low awareness of environmental problems and sustainable development [2]. In recent years, several government documents appeared which changed the former policy into a more pro-environmental one. In 1999 educational system in Poland underwent a major reform, which led to transformation of the structure of school system and introduction of significant changes in the core curriculum. The Ministry of Education has defined educational goals, teaching content, tasks for schools and skills to achieve by students for each level of environmental education in the formal system. In practice, environmental education was limited to providing knowledge about environmental protection [7]. In 2009 the Ministry of Education introduced a new core curriculum [1] for general education in Poland, which was a natural step in shaping environmental education at all levels of teaching. Its main aim was to give more specific goals of education and teaching content, exclude information in excess and focus on developing skills important for scientific reasoning. Environmental issues are incorporated within individual program

of each science subject, and in the form of separate interdisciplinary subject called *natural science*. *Natural science* is particularly important for teaching environmental issues at primary schools. The environmental content present in the core curriculum of individual science subjects (*ie* biology, geography, chemistry and physics) are complementary to each other. The main educational goals of environmental education are: raising the awareness about the threats to the natural environment and actions which can be done to protect the natural environment, and arousing of students' respect for nature. The school's task involves the shaping of students' pro-environmental motivation and attitudes [1]. Teaching chemistry in the context of real-world problems and implementing it in environmental and social issues can help students to close the gap between school science, applications of science and technology, and their critical evaluation [8].

### Materials and methods

The position and estimated market share of textbooks' publishers were basic criteria for selection of analyzed textbooks. Many publishing companies in the education sector refuses to disclose any sales figures regarding school textbooks. It has been only established, that at junior high school level the biggest publishing houses have a strong position, *ie* Wydawnictwa Szkolne i Pedagogiczne (WSiP), Nowa Era, and Oficyna Edukacyjna Krzysztof Pazdro (Pazdro). At senior high school level, decisive leaders are Wydawnictwo Pedagogiczne OPERON and WSiP [9].

Table 1

The list of selected textbooks for teaching chemistry at ISCED 2 and ISCED 3 levels

No.	Code	Textbook title	Authors	Publisher
<b>ISCED 2 level</b>				
1.	J01	Ciekawa chemia. Podręcznik gimnazjalisty. Część 1-3	H. Gulińska, J. Smolińska	WSiP
2.	J02	Chemia w gimnazjum. Podręcznik	Z. Kluz, K. Łopata, E. Odrowąż, M. Poźniczek	WSiP
3.	J03	Chemia 1-3. Podręcznik dla gimnazjum. Część 1-3	M. Szczepaniak, J. Waszczuk	OPERON
4.	J04	Chemia Nowej Ery. Część 1-3. Podręcznik dla gimnazjum	J. Kulawik, T. Kulawik, M. Litwin	Nowa Era
<b>ISCED 3 level</b>				
5.	S01	Chemia. Po prostu. Podręcznik dla szkół ponadgimnazjalnych. Zakres podstawowy	H. Gulińska, K. Kuśmierczyk	WSiP
6.	S02	Chemia. Zakres podstawowy. Podręcznik dla szkół ponadgimnazjalnych	J. Meszko	OPERON
7.	S03	To jest chemia. Podręcznik dla szkół ponadgimnazjalnych. Zakres podstawowy	R. Hass, A. Mrzigod, J. Mrzigod	Nowa Era
8.	S04	Chemia na co dzień. Podręcznik do szkół ponadgimnazjalnych. Zakres podstawowy	K. Pazdro, R. Szmigielski	Pazdro

Currently, there are eight series of chemistry textbooks for ISCED 2 level and seven textbooks for chemistry course at ISCED 3 basic level available at the educational

publishing market. All of them has been approved by the Ministry of National Education as coherent with the new core curriculum for teaching chemistry and admitted for teaching in schools [10]. For the purpose of this study, we selected four textbooks of major Polish educational publishers intended for ISCED 2 stage, and these textbooks were coded with the letter J associated with numbers from 1 to 4. For ISCED 3 stage at basic level we have also chosen four chemistry textbooks, and selected textbooks were coded with the letter S and associated with numbers from 5 to 8. In Table 1 we have listed all the books selected for the purpose of this study.

The core curriculum for chemistry at ISCED 2 and ISCED 3 stages contains several modules with environmental issues. In our study, we decided to investigate curricular teaching content present in selected textbooks with some important extracurricular terms associated with depicted environmental issues (*eg* greenhouse effect, hazard connected with hydrocarbons usage, recycling plastic waste etc.). We classified textbooks' content on the basis of curricular items' presence and its description, number of illustrations per topic and number of questions or tasks for practicing skills in comprehension section. The notes for curricular content representation were as follows: C - this item is present and its description is extensive; A - this item is present and its description is concise; P - this element is only slightly mentioned; and NP - examined element is not present in the textbook. We gave number of illustrations (pictures, schemes, figures or tables) appearing in analyzed topic, since a lot of information was presented in this form. We could not evaluate extracurricular topics in the same way as obligatory items, thus we simply marked their presence by "+" or absence by "-", and any kind of presence was considered to be advantageous.

## Results and discussion

### *Environmental issues in the new core curriculum at ISCED 2 level*

A junior high school (*gimnazjum*) appeared in the Polish educational system in 1999 as a compulsory three-year school intended for educating children from 13 to 16 years old. Study in this type of school ends with an external examination prepared and conducted by Central Examination Commission (*Centralna Komisja Egzaminacyjna*, CKE). The implementation of environmental education in the teaching process at ISCED 2 level relies on the content incorporated in the syllabuses of all science subjects, mainly biology and geography (*natural science* as a separate subject is absent at ISCED 2) but the new core curriculum for teaching chemistry also includes some important topics of this matter.

In the section of general aims of education (learning outcomes), the importance of environmental issues as part of chemistry teaching is indicated by the following goal: *II - Reasoning and application of acquired knowledge to solve problems. Student is aware of the properties connection of various substances with their usage, and their impact on the natural environment* [1]. In the teaching content segment of the curriculum the issues such as ozone depletion, rational water management, air pollution and acid rains are mentioned. Students should acquire the abilities and habits of acting in accordance with the principles of caring for personal health and the protection of the environment. The modules of core curriculum with teaching content connected with environmental problems were listed in Table 2.



Table 2

The environmental content required by the core curriculum for chemistry at ISCED 2 level [1]

Curriculum module	Teaching content	
	No.	Detailed requirements
MODULE 4. Air and other gases	5	Student describes the formation of the ozone hole; suggests the ways of preventing ozone depletion.
	6	Student describes the oxygen cycle.
	10	Student lists sources, types and effects of air pollutants; plans an approach which allows preventing the air pollution.
MODULE 5. Water and water solutions	7	Student suggests the methods of the rational water management.
MODULE 6. Acid and bases	9	Student analyzes the process of the formation of acid rains and the effects of their actions, and suggests ways to limit their formation.
MODULE 8. Carbon and its compounds with hydrogen	1	Student lists the natural sources of hydrocarbons.*
	9	Student describes the properties and applications of polyethylene.*

\*- Parts of module where environmental content is not precisely defined but certain issues can be represented

The content of the core curriculum should be taken literally [1]. This means that all items appearing in the certain topics are mandatory. At this stage of education, environmental teaching is focused basically on the main sources of pollution, the long-term effects of pollution, and the environment protection from the human activities effects. Environmental issues can be classified into four points: i) causes and effects of adverse changes in the atmosphere, hydrosphere and lithosphere; ii) the ways of the natural environment protection from the pollution; iii) threats resulting from the production and transportation of energy; iv) threats to the environment resulting from plastics and plastic waste recycling (optional).

#### *Environmental issues in the new core curriculum at ISCED 3 level*

Senior high schools are attended by the vast majority of the population in the age group 16-19/20 years and are administered by the district authorities. According to the new core curriculum, during 1<sup>st</sup> year at senior high school all students are obliged to perform chemistry course at basic level. The basic course is a natural continuation of chemistry course completed at ISCED 2 level. After this course, students who wish to major in science will continue their education at advanced course of chemistry. Considering the process of educational reform implementation, year 2012 is especially important - students, who had started junior high school with the new teaching program three years ago, took their final exams, and students of all types of senior high schools began the basic course of chemistry for the first time.

The environmental content provided by the learning outcomes of the curriculum at ISCED 3 of the basic level is defined by the following sentence: *II - Reasoning and application of acquired knowledge to solve problems. Student is aware of the properties connection of various substances with their usage, and their impact on the natural environment; uses acquired chemical knowledge in everyday life in the context of caring for personal health and the natural environment* [1]. The environmental knowledge and skills at this stage of teaching is gathered in four modules: i) the cleaning agents influence on the biosphere; ii) the soil degradation; iii) the energy sources and their impact on the natural

environment; iv) the management of waste from various sources. Details of environmental content at ISCED 3 level are listed below.

Table 3

The environmental content required by the core curriculum for chemistry at ISCED 3 level [1]

Curriculum module	Teaching content	
	No.	Detailed requirements
MODULE 2. Chemistry of cleaning agents	3	Student explains the reason for the elimination of phosphates(V) from the composition of washing powders (eutrophication process).
MODULE 4. Soil chemistry	3	Student lists the sources of soil chemical contamination and the basic types of contaminants (heavy metals, hydrocarbons, pesticides, nitrates).
	4	Student proposes the ways of protecting soil from degradation.
MODULE 5. Fuels - at present and in the future	4	Student proposes the alternative sources of energy - analyzes the possibilities of their applications (biofuels, hydrogen, solar power, water power, nuclear power, geothermal, etc.).
	5	Student analyzes the different ways of getting the energy influence on the state of the natural environment.
MODULE 6. Chemistry of packaging and clothing	2	Student classifies plastics according to their properties (thermoplastics and thermosets); writes equations of the chemical reaction for the synthesis of the PVC, indicates risks of gases generated by the combustion of the PVC.
	3	Student justifies the need for the management of waste from various packaging.

### The implementation of obligatory environmental issues in analysed textbooks

The results obtained for the environmental content implementation study at ISCED 2 level are presented in Table 4. Most of environmental issues reviewed for this stage had satisfactory (C or A) correlation with the new core curriculum. Only in one case obligatory item was omitted, *ie* preventing ozone depletion in J02 case. Although the role of nitrogen oxides and chlorofluorocarbons (CFCs) in the ozone hole formation was described in this textbook, there was no explanation how the ozone depletion could be prevented or why the usage of CFCs was restricted. In all examined textbooks terms such as the greenhouse effect, smoky fog and acid rains were discussed. The analysis of rational water management issue revealed that removal of water contaminants and prevention of water pollution were considered in all the textbooks. The term of water treatment plant were omitted in two cases (J02 and J03) and sewage treatment plant was not discussed in J02. On the other hand, extracurricular sources and effects of water pollution were described in detail by all textbooks. Noteworthy is general lack of questions in Modules: 4 (except J03) and 5. All textbooks dealt with the acid rains issue quite extensively. Interestingly, the investigation of plastic waste problems, pollution caused by petroleum leakage and toxicity of carbon monoxide exhibited that such additional topics were raised in some textbooks.

The results for ISCED 3 level study revealed almost excellent coherence with the curriculum for S01, S02 and S04 textbooks (Table 5). In all analyzed textbooks students may find explanation for the elimination of phosphates(V) from the composition of washing powders. Contamination of soil issue was also discussed accurately in all textbooks. It is worth noting that all analysed textbooks had plenty of graphical representations and tasks for alternative sources of energy (except S03). In contrast, indicating the risk of gases generated by the combustion of the PVC was explained very

briefly in S03. The description of waste management from various materials should be regarded as satisfactory in all cases, especially that chemistry curriculum does not mention terms such as waste segregation, recycling or biodegradation. The comprehension section of Module 6 could be better for S03 and S04.

Table 4  
The coherence of environmental content in analyzed textbooks with the core curriculum requirements at ISCED 2 level

Curriculum modules	Textbooks											
	J01			J02			J03			J04		
	Coh. <sup>a</sup>	Ill. <sup>b</sup>	Q <sup>c</sup>	Coh. <sup>a</sup>	Ill. <sup>b</sup>	Q <sup>c</sup>	Coh. <sup>a</sup>	Ill. <sup>b</sup>	Q <sup>c</sup>	Coh. <sup>a</sup>	Ill. <sup>b</sup>	Q <sup>c</sup>
MODULE 4. Air and other gases												
The formation of the ozone hole	C	1	0	C	2	0	C	0	2	C	2	1
The ways of preventing ozone depletion	A	1	0	NP	0	0	A	0	1	C	1	0
The oxygen cycle	C	1	0	C	1	0	C	2	3	C	2	0
Sources, types and effects of air pollution:	C	8	2	C	3	2	C	6	2	C	2	2
- Greenhouse effect*	+	1	1	+	2	2	+	1	2	+	2	2
- Smoky fog*	+	1	1	+	1	0	+	2	1	+	1	1
- Acid rains*	+	0	1	+	0	0	+	1	0	+	1	1
The ways of protecting the air from pollution	C	0	1	C	0	2	C	0	2	C	0	2
MODULE 5. Water and water solutions												
The methods of rational water management	A	1	0	A	0	0	C	0	0	C	0	1
Sources of water pollution*	+	2	0	+	1	0	+	2	0	+	2	0
The effects of water pollution*	+	2	4	+	0	0	+	1	0	+	1	0
Removal of water contaminants	C	2	0	A	0	0	C	0	0	C	1	1
- Sewage treatment plant*	+	1	0	-	-	0	+	0	0	+	1	0
- Water treatment plant*	+	1	0	-	-	1	-	-	-	+	1	1
The prevention of water pollution	C	0	1	A	0	1	C	0	1	A	1	1
MODULE 6. Acid and bases												
The process of the formation of acid rains	C	1	0	C	0	0	C	3	2	C	1	3
The effects of acid rains' actions	C	4	3	C	1	1	C	2	0	C	2	0
The methods of reducing acid rains' formation	A	0	0	A	0	0	C	0	1	C	0	1
MODULE 8. Carbon and its compounds with hydrogen												
The natural sources of hydrocarbons:												
- Pollution caused by petroleum*	+	2	0	-	-	-	P <sup>i</sup>	-	-	P <sup>i</sup>	-	-
- Toxicity of carbon monoxide*	+	1	0	+	0	1	+	0	0	+	0	0
The properties and applications of polyethylene (plastic waste recycling, biodegradation)*	+	0	1	+	0	1	+	1	2	+	1	-

Where: <sup>a</sup> Coh. - coherence; <sup>b</sup> Ill. - number of illustrations; <sup>c</sup> Q - number of related questions; C - this item is present and its description is extensive; A - this item is present and its description is concise; P - this item is only slightly mentioned; NP - this item is not present in the textbook; \* - optional topic; "+" - extracurricular item is present; "-" - extracurricular item is absent; <sup>i</sup> - this item was mentioned in different chapter. Caution: some illustrations and questions were counted more than once as they were related to more than one item.

In our opinion, the curriculum for subject chemistry includes teaching content for ISCED 2 and ISCED 3 stages, which is sufficient in providing knowledge and skills necessary for proper environmental education. However, in some cases curriculum probably left too much freedom for textbooks' authors, thus some mandatory topics were

commented very shortly (*eg* preventing ozone hole) and others were full of illustrations and various tasks to solve (*eg* fuels).

Table 5

The coherence of environmental content in analyzed textbooks  
with the core curriculum requirements at ISCED 3 basic level

Curriculum modules	Textbooks											
	S01			S02			S03			S04		
	Coh. <sup>a</sup>	Ill. <sup>b</sup>	Q <sup>c</sup>	Coh. <sup>a</sup>	Ill. <sup>b</sup>	Q <sup>c</sup>	Coh. <sup>a</sup>	Ill. <sup>b</sup>	Q <sup>c</sup>	Coh. <sup>a</sup>	Ill. <sup>b</sup>	Q <sup>c</sup>
MODULE 2. Chemistry of cleaning agents												
The reason for the elimination of phosphates(V) from the composition of washing powders (eutrophication process)	C	1	3	C	1	1	C	2	2	C	1	1
MODULE 4. Soil chemistry												
The sources of chemical contamination of soils	C	4	1	C	6	1	C	2	0	C	3	2
Basic types of contaminants (heavy metals, hydrocarbons, pesticides, nitrates)	C	4	3	C	3	1	C	1	0	A	4	1
The ways of protecting soil from degradation	C	3	1	C	3	2	C	1	3	C	2	1
MODULE 5. Fuels - at present and in the future												
The alternative sources of energy and the possibilities of their applications	C	11	3	C	20	8	A	1	0	C	10	1
- biofuels, hydrogen, nuclear power	C	5	1	C	14	7	A	1	0	C	7	3
- solar power, water power, geothermal, etc.	C	5	1	C	14	9	A	1	0	C	3	1
The influence of different ways of getting the energy on the state of the natural environment	C	3	1	C	8	8	C	5	3	C	3	1
MODULE 6. Chemistry of packaging and clothing												
Classification of plastics according to their properties (thermoplastics and thermosets)	C	0	2	C	2	0	C	3	1	C	3	0
Indicating the risks of gases generated by the combustion of the PVC	C	1	1	C	0	1	P	0	0	C	2	1
Justifying the need for the management of waste from various packaging	C	3	1	C	1	2	A	0	0	C	1	0
The ways of waste segregation*	+	6	2	C	1	1	+	2	2	+	1	0
Paper recycling*	+	2	1	+	1	1	+	1	1	+	1	0
Glass recycling, selective collection*	+	2	1	+	3	0	+	1	1	+	1	0
Metal recycling*	+	3	2	+	2	1	+	1	1	+	2	0
Plastic waste recycling, biodegradation*	+	9	2	+	3	0	+	4	2	+	3	1

Where: <sup>a</sup> Coh. - coherence; <sup>b</sup> Ill. - number of illustrations; <sup>c</sup> Q - number of related questions; C - this item is present and its description is extensive; A - this item is present and its description is concise; P - this item is only slightly mentioned; \* - optional topic; "+" - extracurricular item is present; <sup>i</sup> - this item was mentioned in different chapter. Caution: some illustrations and questions were counted more than once as they were related to more than one item.

## Conclusions

The new core curriculum for chemistry subject is sufficient in providing awareness of environmental problems among Polish students. The results of this comprehensive study show that all examined textbooks were coherent with environmental issues included in the core curriculum. Most of mandatory topics analyzed in this study had extensive or concise description. We have noticed only two cases where the required items were omitted or slightly mentioned. It is a matter of discussion, whether certain items in the new core curriculum should be more specific to avoid overloading textbooks with huge amount of

information without paying enough attention to obligatory issues, *eg* the rational water management or the waste management from various sources.

### Acknowledgements

This project is co-funded by European Union within European Social Fund.

### References

- [1] Ministerstwo Edukacji Narodowej: Podstawa programowa z komentarzami, T.5. Edukacja przyrodnicza w szkole podstawowej, gimnazjum i liceum; przyroda, geografia, biologia, chemia, fizyka, MEN, 2009. [http://www.men.gov.pl/images/stories/pdf/Reforma/men\\_tom\\_5.pdf](http://www.men.gov.pl/images/stories/pdf/Reforma/men_tom_5.pdf).
- [2] Grodzińska-Jurczak M. Environmental education in Poland: Its present status. *Int Res Geogr Environ Educ.* 2004;13(3):251-257. DOI: 10.1080/10382040408668519.
- [3] Embros G. Control and Optimization in Sustainable Development. A Humanist Approach to Sustainable Development. Łepko Z, Sadowski R, editors. Warszawa: Wyd Uniwersytetu Kardynała Stefana Wyszyńskiego; 2009.
- [4] Cichy D. (Ed.) Edukacja środowiskowa wzmocnieniem zrównoważonego rozwoju. Warszawa: Instytut Badań Edukacyjnych, Wyższa Szkoła Pedagogiczna ZNP; 2005.
- [5] Tilbury D, Stevenson RB, Fien J, Schreuder D, editors. Education and Sustainability: Responding to the Global Challenge. Commission on Education and Communication, Switzerland and Cambridge, UK: IUCN, Gland; 2002.
- [6] Kollmuss A, Agyeman J. Mind the Gap: Why do people act environmentally and what are the barriers to pro-environmental behavior? *Environ Educ Res.* 2002;8(3):239-260. DOI: 10.1080/13504620220145401.
- [7] Kobierska H, Tarabula-Fiertak M, Grodzińska-Jurczak M. Attitudes to environmental education in Poland. *J Biol Educ.* 2007;42(1):12-18. DOI: 10.1080/00219266.2007.9656101.
- [8] Mandler D, Mamlok-Naaman R, Blonder R, Yayon M, Hofstein A. High-school chemistry teaching through environmentally oriented curricula. *Chem Educ Res Pract.* 2012;13(2):80-92. DOI: 10.1039/C1RP90071D.
- [9] Rynek książki: Czy tanie może być dobre? 2011, [http://rynek-ksiazki.pl/szukaj/czy-tanie-moze-byc-dobre\\_27767.html](http://rynek-ksiazki.pl/szukaj/czy-tanie-moze-byc-dobre_27767.html).
- [10] Data source: [http://www.men.gov.pl/podreczniki/dopuszczone\\_lista1.php?file=gimnazjum](http://www.men.gov.pl/podreczniki/dopuszczone_lista1.php?file=gimnazjum).

## ELEMENTY EDUKACJI PROŚRODOWISKOWEJ W NOWEJ PODSTAWIE PROGRAMOWEJ PRZEDMIOTU CHEMIA ORAZ W WYBRANYCH PODRĘCZNIKACH DO NAUCZANIA CHEMII DLA III I IV ETAPU KSZTAŁCENIA

Pracownia Przedmiotów Przyrodniczych, Instytut Badań Edukacyjnych, Warszawa

**Abstrakt:** W 2009 roku Ministerstwo Edukacji Narodowej wprowadziło nową podstawę programową kształcenia ogólnego w Polsce, która przekształciła całkowicie edukację środowiskową na III (gimnazjum) i IV (szkoły ponadgimnazjalne) etapie kształcenia. Biorąc pod uwagę ogromny wpływ substancji chemicznych na stan środowiska naturalnego, podstawa programowa przedmiotu chemia pełni istotną rolę w rozwijaniu wiedzy środowiskowej oraz postaw prośrodowiskowych wśród uczniów polskich szkół. Bez wątpienia, podręczniki chemiczne są nie tylko podstawowym źródłem wiedzy naukowej dla uczniów, ale także inspiracją dla nauczycieli przygotowujących zajęcia lekcyjne. Reforma edukacyjna narzuciła konieczność zaktualizowania podręczników do nauki chemii zgodnie z nową podstawą programową. Celem niniejszej pracy było zbadanie spójności elementów edukacji prośrodowiskowej wymaganych w nowej podstawie programowej z omówieniem tych zagadnień zaproponowanym w wybranych podręcznikach. Analizie poddano podręczniki dla szkół gimnazjalnych i ponadgimnazjalnych (zakres podstawowy) wydane przez największe polskie wydawnictwa edukacyjne. Wyniki tego badania wskazują, że wszystkie analizowane podręczniki są zgodne z treściami kształcenia prośrodowiskowego zawartymi w podstawie programowej, a jeśli to konieczne, zawierają także dodatkowe wiadomości nieujęte podstawą programową (np. problemy z odpadami związków organicznych). Porównanie

wybranych podręczników dostarczyło informacji o stanie obecnym wdrażania reformy edukacyjnej oraz o elementach nowej podstawy programowej dotyczących problemów środowiskowych, które warto poprawić lub uściślić.

**Słowa kluczowe:** edukacja prośrodowiskowa, postawa prośrodowiskowa, nowa podstawa programowa, podręczniki chemiczne

Kamila J. NOWAK<sup>1</sup>, Andrzej T. SOLECKI<sup>1</sup> and Tobiasz J. SZADEJ<sup>1</sup>

## RADIOLOGICAL RISK OF THE URANIFEROUS COAL WASTE IN THE CASE OF THE LANDSCAPE ARCHITECTURE APPLICATION

### RYZKO RADIOLOGICZNE ZWIĄZANE Z ZASTOSOWANIEM ODPADÓW Z HAŁD URANONOŚNYCH WĘGLI W ELEMENTACH ARCHITEKTURY KRAJOBRAZU

**Abstract:** Gamma-spectrometric measurements of four (A, B, C, D) spoil tips, by means of portable gamma spectrometers RS230 have been performed in the Okrzeszyn area of the Intrasudetic Synclinorium, where uraniferous Permocarbiniferous coal exploitation and uranium prospecting took place in the past. The obtained results of K, U, Th content were recalculated into activity indices  $f_1$  and  $f_2$ . Acceptable limits according to Polish Law are  $f_1 \leq 1$  and  $f_2 \leq 200 \text{ Bq} \cdot \text{kg}^{-1}$  for raw materials in buildings for people and livestock. Obtained results indicate that spoil tips material cannot be fully accepted as building material even for landscape architecture constructions in urban areas, where limits are less restrictive ( $f_1 \leq 2$ ,  $f_2 \leq 400 \text{ Bq} \cdot \text{kg}^{-1}$ ).

**Keywords:** uranium, coal, gamma spectrometry, Sudetes

#### Introduction

Okrzeszyn, a small village located in the western part of the Intrasudetic Synclinorium close to its boundary with the Karkonosze-Izera Block has been the place of coal exploitation since the 18-th century. Coal seams intercalated with mudstones, sandstones and conglomerates represent the uppermost part of the Carboniferous and are overlain by the Early Permian conglomerates, sandstones and mudstones (black *Anthracosia* shale). Sedimentation of the above-mentioned rocks has been accompanied by bimodal volcanism (intermediate-trachyandesites and felsic-rhyolites) [1]. Sedimentary sequence represents the fossil record of climate change from relatively wet, with regular precipitation, when peat bogs were formed to dry, arid conditions with irregular, but intensive rainfalls of red conglomerate sedimentation [2, 3].

Due to this, periods of intensive chemical weathering were followed by dry seasons, when accumulated material stayed in oxygenating conditions. Even during Permian dry climate period, the buried peat layers maintained acid, reducing conditions, what combined with their absorption activity resulted in uranium precipitation from circulating oxygenated groundwater. Especially effective adsorbent systems were connected with thin layers of peat (slowly transforming to lignite and coal) surrounded by permeable sand (sandstones). Uranium in groundwater was derived from oxygenated weathering zones of sedimentary debris and massifs of acid igneous rocks (local felsic rhyolites and Karkonosze Granite) and maybe to some extent also from the late hydrothermal fluids. According to uranium prospecting reports of the mid XX-th century uranium concentration in thin coal seams reaches thousands of ppm, but low thickness make their exploitation uneconomic [3, 4].

---

<sup>1</sup> Institute of Geological Sciences, University of Wrocław, pl. M. Borna 9, 50-204 Wrocław, phone 71 375 94 36, email: andrzej.solecki@ing.uni.wroc.pl

As a result of coal mining and uranium prospecting spoil tips - piles of rock waste material exist in this area [5]. Their main components are: black shales and mudstones with abundant organic matter, sandstones and conglomerates. Four spoil tips (A, B, C, D) has been studied, their composition varies from place to place and so does the radionuclides content.

## Methods

Gamma-spectrometric measurements were performed by means of portable gamma spectrometers RS230 with BGO detectors and automatic gain stabilization based on thallium  $^{208}\text{Tl}$  emission at 2615 keV. The results were registered as potassium content K [%], equivalent uranium content eU [ppm], equivalent thorium content eTh [ppm]. Later on the results were recalculated into activity indices f1 and f2.

## Results and radiological risk assessment

Obtained results are summarized in the Table 1.

Table 1

Summary of radiometric results

Location	Statistical parameter	K [%]	eU [ppm]	eTh [ppm]	f1	f2 [Bq · kg <sup>-1</sup> ]
SPOIL TIP A	max	4.4	29.1	23.9	1.9	361.77
	min	2.1	6.2	15.4	0.91	77.08
	mean	2.8	14.4	18.9	1.3	179.3
SPOIL TIP B	max	3.9	148.5	25	7.02	1846.14
	min	2.2	2.9	10.3	0.61	36.05
	mean	2.99	59.82	19.43	3.18	743.67
SPOIL TIP C	max	2.8	59.2	13.4	3.01	735.97
	min	2.2	3.3	10.1	0.58	41.03
	mean	2.5	24.5	11.4	1.5	304.4
SPOIL TIP D	max	2.5	158.8	13.6	7.07	1974.19
	min	2.1	23.5	8.8	1.37	292.15
	mean	2.27	65.6	10.33	3.16	815.53
OUTSIDE AREA	max	2.6	36.6	21.3	2.16	443.82
	min	0.8	2.5	7.1	0.39	31.08
	mean	1.73	18.1	9.86	1.13	225.02

Basic parameters of radiological risk assessment are according to Polish Law f1 and f2 indices. Index f1 is a weighted average of specific activities of  $^{40}\text{K}$  isotope and radionuclides of uranium  $^{238}\text{U}$  and thorium  $^{232}\text{Th}$  decay series, described by the formula:

$$f1 = \frac{S_K}{3000 \text{ Bq} \cdot \text{kg}^{-1}} + \frac{S_{Ra}}{300 \text{ Bq} \cdot \text{kg}^{-1}} + \frac{S_{Th}}{200 \text{ Bq} \cdot \text{kg}^{-1}}$$

where  $S_K$ ,  $S_{Ra}$ ,  $S_{Th}$  are specific activities of  $^{40}\text{K}$ ,  $^{226}\text{Ra}$  and  $^{228}\text{Th}$  in  $\text{Bq} \cdot \text{kg}^{-1}$ , respectively.



As visible from the formula above  $f_1$  value can be treated as a sum of three components connected with radiation of  $^{40}\text{K}$ ,  $^{226}\text{Ra}$  and  $^{232}\text{Th}$ , respectively.

Frequency distribution of the  $f_1$  index is presented in Figure 1.

Shares of the  $^{40}\text{K}$ ,  $^{238}\text{U}$  and  $^{232}\text{Th}$  components in the total  $f_1$  values are shown in the Figure 2. Each bar represents calculated value of  $f_1$  and is composed of three layers of different grey tone. The lowest layer corresponds to  $^{40}\text{K}$  component of  $f_1$  value, the medium layer corresponds to  $^{238}\text{U}$  component of  $f_1$  value and the uppermost layer corresponds to  $^{232}\text{Th}$  component of  $f_1$  value.  $^{238}\text{U}$  component is the most significant and the most variable one.

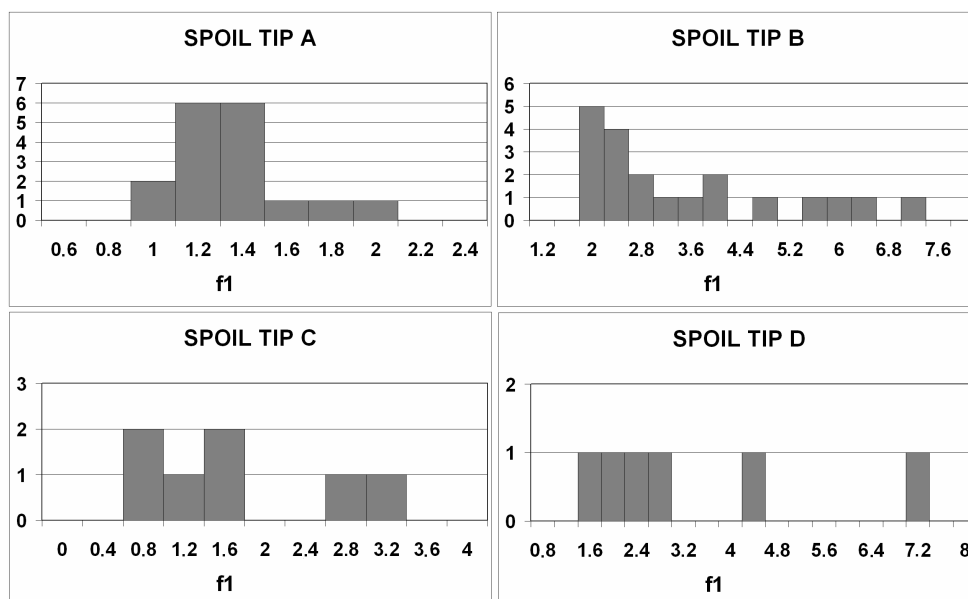

Fig. 1. Frequency distribution of  $f_1$  index

Index  $f_2$  is a measure of radon risk expressed as  $^{226}\text{Ra}$  specific activity of the material. Frequency distribution of  $f_2$  index is presented in Figure 3.

Legally accepted values of the above-mentioned indices are:

- 1)  $f_1 \leq 1$  and  $f_2 \leq 200 \text{ Bq} \cdot \text{kg}^{-1}$  for raw materials and construction materials used in dwellings designed to accommodate people and livestock,
- 2)  $f_1 \leq 2$  and  $f_2 \leq 400 \text{ Bq} \cdot \text{kg}^{-1}$  for industrial waste used in above-ground building constructions erected in the urban areas and leveling of the areas designed for urbanisation purposes in the local spatial plan,
- 3)  $f_1 \leq 3.5$  and  $f_2 \leq 1000 \text{ Bq} \cdot \text{kg}^{-1}$  for industrial waste used in above-ground parts of buildings not listed in point 2, and the leveling of areas not listed in point 2,
- 4)  $f_1 \leq 7$ ,  $f_2 \leq 2000 \text{ Bq} \cdot \text{kg}^{-1}$  for industrial waste for use in underground parts of buildings referred to in point 3, and underground structures, including rail and road tunnels, with the exception of industrial waste used in underground mining.

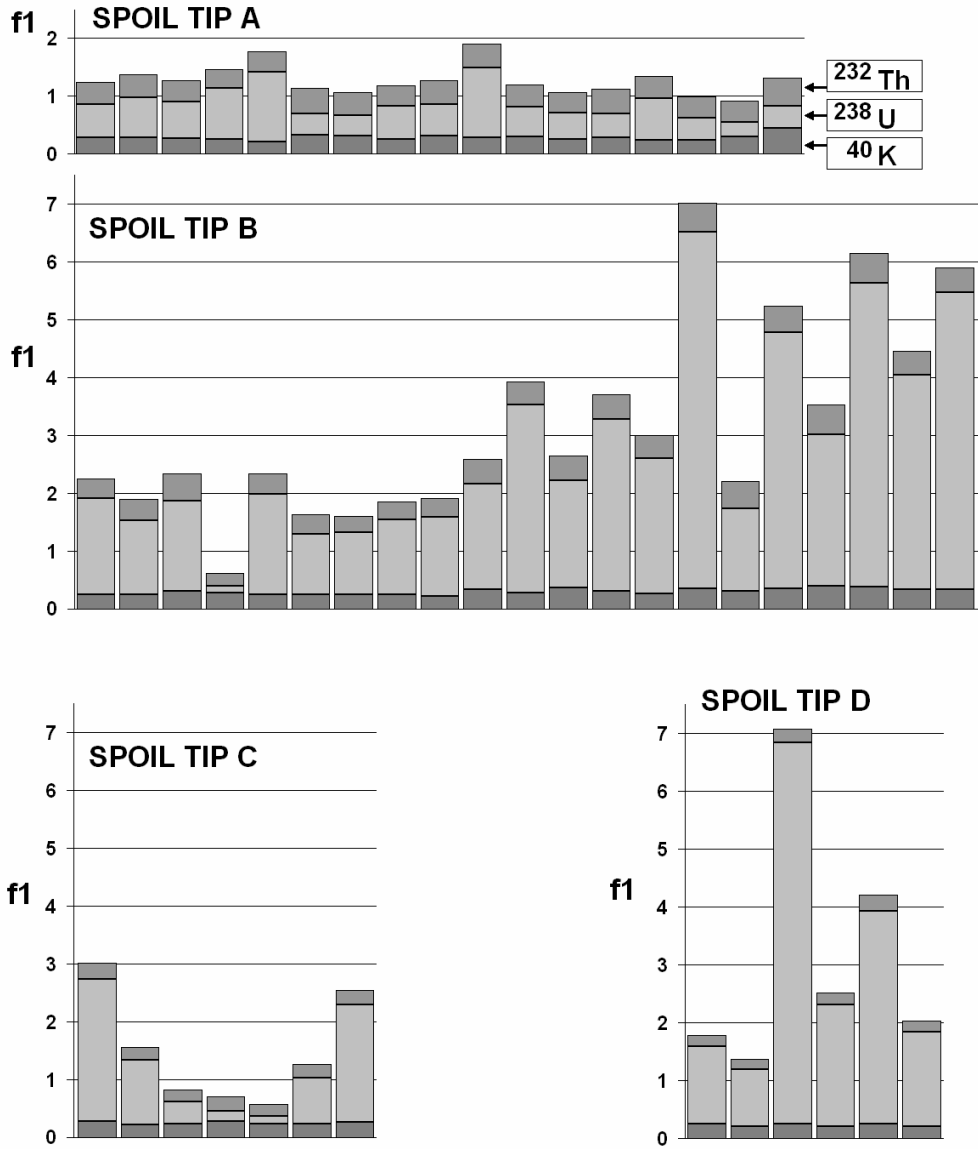

Fig. 2. Shares of the  $^{40}\text{K}$ ,  $^{238}\text{U}$  and  $^{232}\text{Th}$  components in the total f1 values

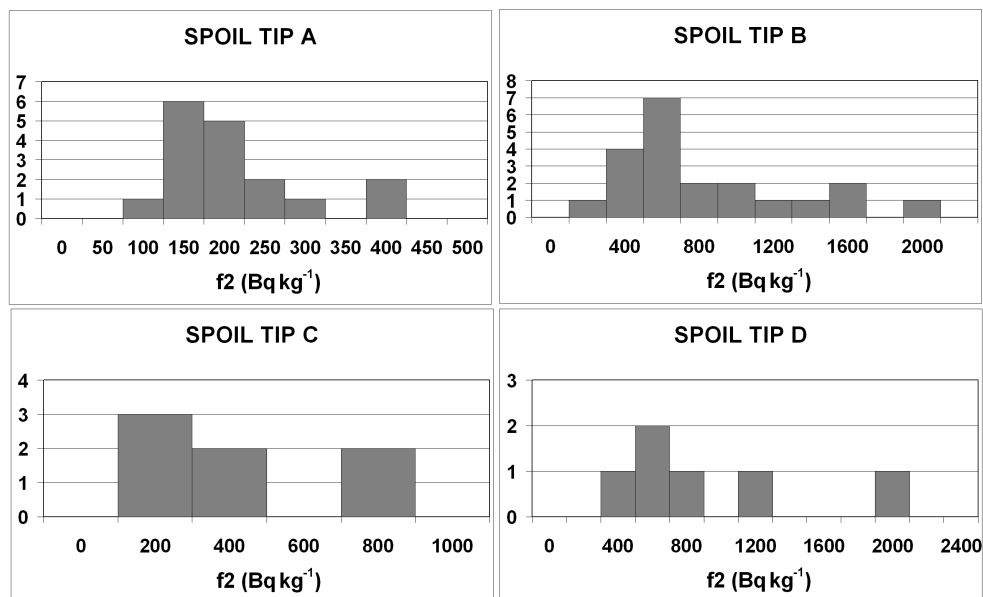

Fig. 3. Frequency distribution of f2 index [Bq · kg<sup>-1</sup>]

## Conclusions

Obtained results indicate that spoil tips material cannot be fully accepted as building material even for above-ground landscape architecture constructions in urban areas, where limits are less restrictive ( $f_1 \leq 2$ ,  $f_2 \leq 400$  Bq · kg<sup>-1</sup>). It can be used after radiological control in limited range for road construction outside urban areas ( $f_1 \leq 3.5$  and  $f_2 \leq 1000$  Bq · kg<sup>-1</sup>). There are no restrictions for application in the underground parts of buildings, and underground structures, including rail and road tunnels outside urban areas.

## Acknowledgements

Research was funded by the grant No. 1017/S/ING/12-V.

## References

- [1] Awdankiewicz M. Sedimentation, Volcanism and Subvolcanic Intrusions in a Late Palaeozoic Intramontane Trough (the Intra-Sudetic Basin, SW Poland). Geological Society. London: Special Publications; 2004;234:5-11. DOI: 10.1144/GSL.SP.2004.234.01.02.
- [2] Osika R. Geology of Poland, Mineral Deposits, Volume VI. Mineral Deposits. Warsaw: Publishing House Wydawnictwa Geologiczne; 1990:314 pp.
- [3] Solecki A, Śliwiński W, Wojciechowska I, Tchorz-Trzeciakiewicz D, Syrczyński P, Sadowska M, Makowski B. Ocena możliwości występowania mineralizacji uranowej w Polsce na podstawie wyników prac geologiczno-poszukiwawczych. *Przeł Geolog.* 2011;59:98-110.
- [4] Solecki AT, Puchała R, Tchorz DE. Radon and its decay product activities in magmatic area of the Karkonosze Granite and the adjacent volcano-sedimentary Intrasudetic Basin. *Annals of Geophysics.* 2007; 50(4):579-585. DOI:2122/3871.

- [5] Piestrzynski A, Pieczonka J. Impact of uranium mining on the local environment, Lower Silesia, Poland. In: Pasava J, Kribek B, Zak K, editors. Mineral Deposits: From their Origin to their Environmental Impacts. Rotterdam, Netherlands: A.A. Balkema; 1995:693-696.

## **RYZIKO RADIOLOGICZNE ZWIĄZANE Z ZASTOSOWANIEM ODPADÓW Z HAŁD URANONOŚNYCH WĘGLI W ELEMENTACH ARCHITEKTURY KRAJOBRAZU**

Instytut Nauk Geologicznych, Uniwersytet Wrocławski

**Abstrakt:** Zostały przeprowadzone pomiary za pomocą gamma spektrometrów RS230 na czterech (A, B, C, D) hałdach odpadów górniczych w rejonie Okrzeszyna (niecka śródsudecka), gdzie w przeszłości miała miejsce eksploatacja permokarbońskich uranonośnych węgla i poszukiwanie rud uranu. Uzyskane wyniki zawartości K, U, Th zostały przeliczone na wskaźniki aktywności  $f_1$  i  $f_2$ . Zgodnie z Rozporządzeniem RM z dnia 2 stycznia 2007 r., dopuszczalne wartości wynoszą  $f_1 \leq 1$  i  $f_2 \leq 200 \text{ Bq} \cdot \text{kg}^{-1}$  w przypadku materiałów stosowanych w budynkach mieszkalnych. Uzyskane wyniki wskazują, że zgromadzony na hałdach materiał nie może być w całości dopuszczony nawet do budowy elementów architektury krajobrazu w obszarach zabudowanych, gdzie dopuszczalne wartości wskaźników aktywności są większe ( $f_1 \leq 2$ ,  $f_2 \leq 400 \text{ Bq} \cdot \text{kg}^{-1}$ ).

**Słowa kluczowe:** uran, węgiel, gamma spektrometria, Sudety

Halina PAWLAK-KRUCZEK<sup>1</sup> and Maciej ZAWIŚLAK<sup>2</sup>

## CFD MODELING OF PULVERIZED COAL COMBUSTION IN AIR AND OXY ATMOSPHERE - NO<sub>x</sub> AND SO<sub>2</sub> FORMATION

### MODELOWANIE CFD SPALANIA PYŁU WĘGLOWEGO W ATMOSFERZE POWIETRZA I OXY: POWSTAWANIE NO<sub>x</sub> I SO<sub>2</sub>

**Abstract:** Despite the fact that alternative energy sources sector has been rapidly developed since last years, coal combustion as a major fossil-fuel energy resource (especially in Poland) will continue being a major environmental concern for the next few decades. To meet future targets for the reduction of toxic and greenhouse gases emission new combustion technologies need to be developed: pre-combustion capture, post-combustion capture, and oxy-fuel combustion. This paper deals with the air-fired and oxy-fuel coal combustion (pulverized coal) combustion, and its impact on pollutants (NO<sub>x</sub> and SO<sub>2</sub>) formation. For CFD (*Computational Fluid Dynamics*) modeling of media flows and coal combustion process the laboratory model of combustion reactor was applied. The material input was set based on technical-elementary analysis of pulverized coal used in experiment and sieves grain-size analysis. Boundary conditions (media flows intensities and temperatures) were set based on laboratory experimental measurements. Radiation case-sensitive WSGGM model (weighted - sum - of - gray - gases model) was used for calculation. The modeling was proceed for different combustion parameters in air and OXY atmosphere in oxygen/fuel ratio variation and fuel humidity variation function.

**Keywords:** CFD modeling, coal combustion, radiation model

### Introduction

The role of coal as an energy source has attracted renewed interest due to the stability of its supply and its relatively low cost, which will probably guarantee its inclusion in the energy mix in the foreseeable future [1]. However, coal combustion produces a large amount of CO<sub>2</sub>, which is the chief contributor to global climate change. To meet future targets for the reduction of greenhouse gas emissions, CO<sub>2</sub> must be captured and stored [2]. Oxy-coal combustion is a carbon abatement technology that can be used for the capture of carbon dioxide (CO<sub>2</sub>) from coal-fired power plants. The amount of unburnt carbon or the *Loss on Ignition* (LOI) depends on the particle residence time in the furnace, the temperature and the availability of oxygen along the particle path [3].

Considerable knowledge of the fundamentals of heat and mass transfer, combustion processes and pollutant formation under CO<sub>2</sub> - rich conditions has been acquired through extensive experiments and modeling efforts in recent years. However, many fundamental issues remain uninvestigated [4]:

- Oxy-combustion characteristics of different coal types.
- Models for sub-processes (models for devolatilization, char formation, agglomeration and coal group combustion under the oxy-combustion conditions are mostly based on air combustion studies).

---

<sup>1</sup> Faculty of Mechanical and Power Engineering, Wrocław University of Technology, ul. Wybrzeże Wyspiańskiego 27, 50-370 Wrocław, phone 71 320 39 42

<sup>2</sup> Institute of Machine Design and Operation, Faculty of Mechanical Engineering, Wrocław University of Technology, ul. Wybrzeże Wyspiańskiego 27, 50-370 Wrocław, phone 71 320 26 67, email: maciej.zawislak@pwr.wroc.pl

- Scaling characteristics of oxy-combustion.
- Pressure effect (when operating under elevated pressure, the gas phase flowfield and coal particle residence time may change significantly).

An important issue of implementation this technology is also its impact on problem of pollutants formation *ie* thermal NO<sub>x</sub> due to the absence of nitrogen gas in the combustion atmosphere and SO<sub>2</sub> formation from contaminated fossil fuel.

The authors present results of simulation which aim was investigation of NO<sub>x</sub> and SO<sub>2</sub> forming during coal combustion process in the laboratory reactor using numerical tools.

## Methodology

For CFD modeling of media flows and coal combustion process the laboratory model of combustion reactor was applied. The material input was set based on technical-elementary analysis of pulverized coal used in experiment and sieves grain-size analysis. Boundary conditions (media flows intensities and temperatures) were set based on laboratory experimental measurements. Radiation case-sensitive WSGGM model (*weighted-sum-of-gray-gases model*) was used for calculation. The modeling was proceed for different combustion parameters in air and OXY atmosphere in oxygen/fuel ratio variation and fuel humidity variation function.

### Boundary conditions

In Table 1 the results of technical-elementary analysis of applied fuel are presented.

Table 1

Technical-elementary analysis of applied fuel (pulverized coal)

Coal proximate analysis	
Moisture content [wt.%]	13.23
Ash [wt.% db] <sup>*</sup>	4.96
V.M. [wt.% db]	30.64
F.C. [wt.% db]	51.17
Heating value [MJ/kg db]	25.5
Ultimate analysis [wt.% daf] <sup>**</sup>	
C	73.60
H	5.26
N	1.44
S	0.80
O	18.9
Sieves grain-size analysis: fraction [%]	
< 63 μm	34.08
63-80 μm	26.51
80 μm-0.106 mm	25.29
0.106-0.160 mm	7.39
> 0.2 mm	6.73

\* (wt.) - weight, (db) - dry base

\*\* (wt.) - weight, (daf) - dry ash free

Five lambda coefficient value ( $\lambda$ : 0.83; 1.0; 1.1; 1.3; 1.35) and four values of humidity ( $\varphi$ : 0, 7, 14, 21) was chosen to the modeling.

## Results

The results were presented in tables and in figures below.

Table 2

Simulation results: NO<sub>x</sub>, SO<sub>2</sub>, CO<sub>2</sub>, O<sub>2</sub> concentrations in  $\lambda$  and humidity function

$\phi$ [%]	NO <sub>x</sub> [ppm]				SO <sub>2</sub> [ppm]				CO <sub>2</sub> [% vol.]				O <sub>2</sub> [% vol.]			
	0	7	14	21	0	7	14	21	0	7	14	21	0	7	14	21
$\lambda$	<b>air</b>															
0.83	0	0	9	87	1545	1453	1400	1308	16.9	16.9	16.5	14.9	0	0	0.1	1.8
1.00	53	75	114	255	1321	1251	1177	1104	16	14.9	14	12.9	1.3	2.4	3.4	4.4
1.10	104	137	229	290	1219	1157	1091	1019	14.7	13.8	13	12.1	2.9	3.8	4.6	5.5
1.20	163	208	288	367	1123	1068	1007	942	13.4	12.7	11.9	11.1	4.4	5.11	5.9	6.8
1.35	288	342	400	430	1012	957	902	844	11.9	11.4	10.6	10	6.2	6.7	7.6	8.2
$\lambda$	<b>OXY 20/80</b>															
0.83	40	54	72	100	1139	1087	1015	953	90.3	88.6	86.9	85.1	1.9	3.1	4.2	5.5
1.00	81	93	150	190	955	904	852	799	87.7	86.4	85	83.5	5.8	6.6	7.6	8.6
1.10	132	175	204	215	880	835	786	738	86.6	85.3	84	82.8	7.4	8.2	9.2	9.8
1.20	154	194	232	300	812	768	725	680	85.7	84.5	83.3	82.1	8.7	9.6	10.4	11.2
1.35	193	267	297	304	726	688	649	609	84.5	83.5	82.4	81.4	10.5	11.2	11.9	12.6
$\lambda$	<b>OXY 25/75</b>															
0.83	45	55	88	119	1156	1096	1033	970	84.6	83.2	81.4	79.6	7.6	8.5	9.8	11
1.00	84	124	143	185	971	921	868	813	82.1	80.7	79.5	77.9	11.4	12.4	13.1	14.1
1.10	117	142	192	256	895	849	800	750	81.1	79.8	78.6	77.3	12.9	13.7	14.5	15.4
1.20	147	209	242	287	825	782	738	691	80.1	79	77.8	76.6	14.4	15.1	15.9	16.6
1.35	198	258	289	346	738	700	660	619	78.9	77.9	76.8	75.7	16.2	16.8	17.6	18.2
$\lambda$	<b>OXY 30/70</b>															
0.83	52	62	83	117	1175	1114	1051	984	79.4	77.7	76.2	74.5	12.8	14.1	15	16.2
1.00	90	126	152	205	987	935	882	826	76.8	75.5	74.1	72.7	16.8	17.6	18.5	19.4
1.10	119	176	209	232	909	862	813	762	75.7	74.5	73.2	71.9	18.3	19.1	19.9	20.7
1.20	138	199	262	300	838	794	749	702	74.7	73.5	72.4	71.2	19.8	20.6	21.3	22
1.35	214	276	326	390	749	710	670	627	73.4	72.4	71.4	70.3	21.7	22.3	22.9	23.6

In Figure 1 the chosen results of particular exhaust gases components concentrations are presented in lambda coefficient function on example of 7% humidity content in the fumes.

The highest carbon dioxide concentration was observed during the fuel combustion in 20/80 oxy-atmosphere, the insignificant decrease (about 8%) of CO<sub>2</sub> concentration was noticed for all oxy-coal combustion processes.

The nitric oxides concentration was rapidly rising due to lambda coefficient increase - in case of all oxy-coal combustion processes a concentration range was reduced and its maximum level is lower more than 100 ppm in comparison to air combustion.

Despite the fact that SO<sub>2</sub> concentration pattern is similar for all oxy-atmospheres and for the air-atmosphere, the SO<sub>2</sub> contents in the exhausts in case of oxy-coal combustion is about 400 ppm lower in comparison to air-combustion process.

For the investigation of the pollutants formation, molar fraction of SO<sub>2</sub> and NO was calculated and presented in function of position inside the combustion reactor (Table 3) on the example of 1.2 value of lambda coefficient and 7% humidity contents in the fumes.

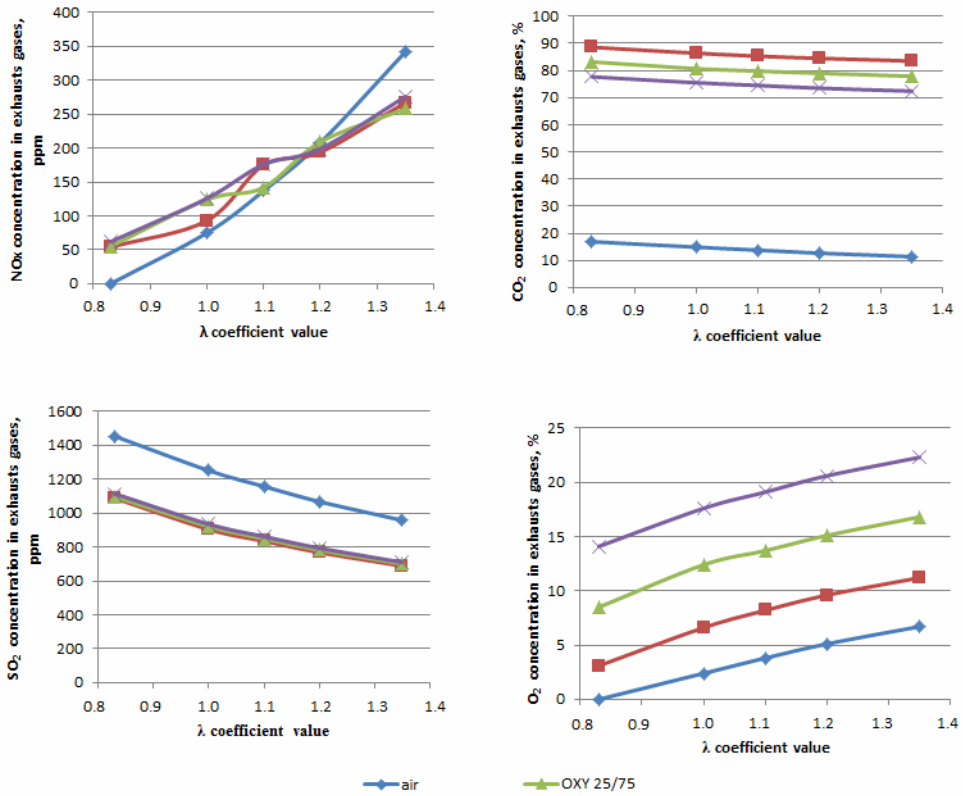
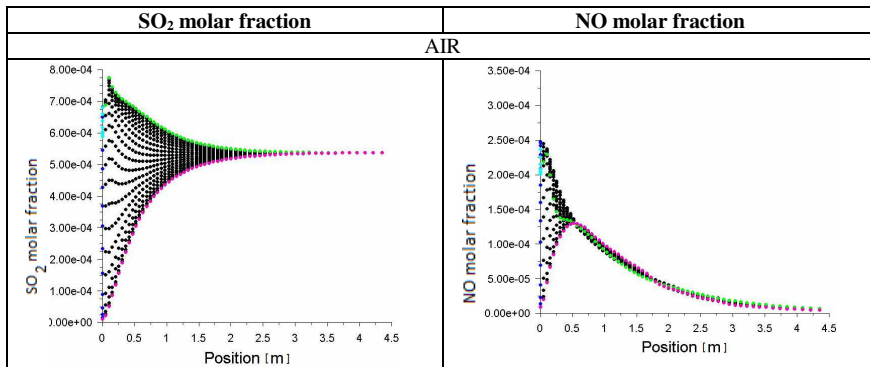

Fig. 1. The concentration of NO<sub>x</sub>, SO<sub>2</sub>, O<sub>2</sub> and CO<sub>2</sub> in lambda coefficient function for various OXY atmosphere (7% humidity content in the fumes)

Table 3

The molar fraction of pollutants in function of position inside the combustion reactor: λ = 1.2, φ = 7%





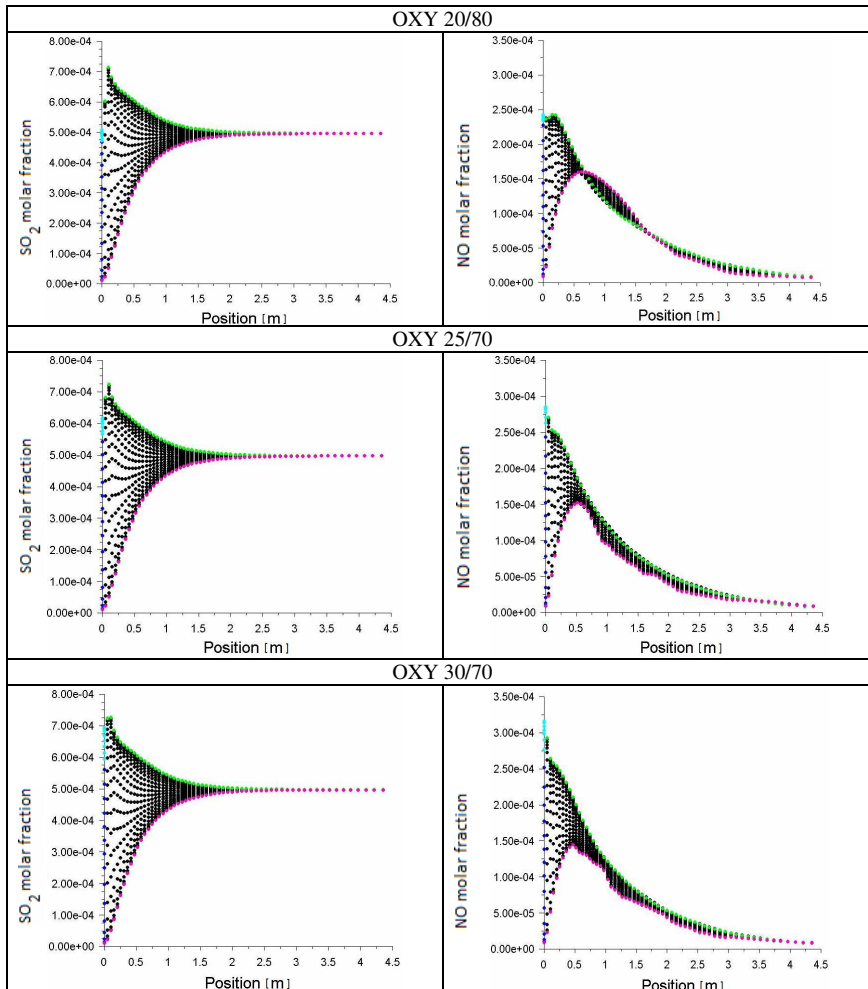

The results of the model researches show that the distribution of  $\text{SO}_2$  molar fraction is very similar in case of oxy-coal combustion process in comparison to air-coal combustion, but in case of oxy-atmosphere range of molar fraction is going to contract closer to the reactor inlet. In case of  $\text{NO}$  molar fraction distribution the changes in position inside of the reactor in case of oxy and air coal combustion is more visible. The process of  $\text{NO}$  conversion and concentration stabilization seems to take longer during oxy-coal combustion than in case of the combustion in air atmosphere.

## Summary

CFD approaches have been used in studies to better understand the flowfield and combustion processes in oxy-coal combustion and provide predictions of minor species and

pollutant formations. Radiation heat transfer plays a major role in the furnace, and it also governs the energy equation in combustion. The authors of the paper applied turbulence-radiation model for simulation.

The results of the modeling oxy-coal combustion indicate that the method is more advantageous in aspect of pollutant emission than air-combustion of coal. The pollution formation in the reactor seems to proceed in visible different mode than in air-coal combustion process. The CFD modeling of the oxy-coal combustion process is a proper tool for oxy-coal process investigation and understanding for better control of pollutant emission by combustion parameters optimization.

## References

- [1] Gharebaghi M, Irons R., Pourkashanian M, Williams A. An investigation into a carbon burnout kinetic model for oxy-coal combustion. *Fuel Processing Technol.* 2011;92:2455-2464. DOI: <http://dx.doi.org/10.1016/j.fuproc.2011.08.015>.
- [2] Riaza J, Álvarez L, Gil MV, Pevida C, Pis JJ, Rubiera F. Effect of oxy-fuel combustion with steam addition on coal ignition and burnout in an entrained flow reactor. *Energy.* 2011;36:5314-5319. DOI: <http://dx.doi.org/10.1016/j.energy.2011.06.039>.
- [3] Riaza J, Álvarez L, Gil MV, Pevida C, Pis JJ, Rubiera F. Oxy-fuel combustion of coal and biomass blends. *Energy.* 2012;41:429-435, <http://dx.doi.org/10.1016/j.energy.2012.02.057>.
- [4] Chen L, Yong SZ, Ghoniem AF. Oxy-fuel combustion of pulverized coal: Characterization, fundamentals, stabilization and CFD modeling. *Review. Progress in Energy and Combustion Sci.* 2012;38:156-214. DOI: <http://dx.doi.org/10.1016/j.egypro.2012.06.054>.

## MODELOWANIE CFD SPALANIA PYŁU WĘGLOWEGO W ATMOSFERZE POWIETRZA I OXY: POWSTAWANIE $\text{NO}_x$ I $\text{SO}_2$

<sup>1</sup> Wydział Mechaniczno-Energetyczny

<sup>2</sup> Instytut Konstrukcji i Eksploatacji Maszyn, Wydział Mechaniczny  
Politechnika Wrocławska

**Abstrakt:** Pomimo faktu gwałtownego rozwoju sektora alternatywnych źródeł energii w ostatnich dziesięcioleciach, spalanie węgla jako najważniejszego źródła energii konwencjonalnej (w szczególności w Polsce) jest bardzo istotnym zagadnieniem w aspekcie ochrony i inżynierii środowiska. Nowe wyzwania w zakresie obniżania emisji związków toksycznych, a także gazów cieplarnianych wymuszają rozwój w zakresie innowacyjnych technologii spalania węgla: pierwotnych (na etapie substratów) oraz wtórnych (na etapie produktów), a także modyfikacji procesu spalania (atmosfera OXY). W artykule przedstawiono zagadnienie formowania się zanieczyszczeń ( $\text{NO}_x$  oraz  $\text{SO}_2$ ) powstających podczas procesu spalania pyłu węglowego w atmosferze powietrza oraz atmosferze OXY. Do obliczeń metodą CFD (przepływu i spalania mieszanki powietrzno-węglowej) wykorzystano model laboratoryjnego pieca opadowego. Jako warunki brzegowe do obliczeń zastosowano wyniki analiz techniczno-elementarnych pyłu węglowego, przedziały frakcyjne cząstek ustalono na podstawie analizy sitowej. Warunki brzegowe (temperaturę pieca, doprowadzanego powietrza oraz paliwa, natężenia przepływu powietrza pierwotnego i wtórnego) ustalono na podstawie pomiarów rzeczywistych w warunkach laboratoryjnych. W celu zamodelowania spalania z uwzględnieniem radiacji wykorzystano model WSGGM (weighted-sum-of-gray-gases model). Obliczenia z uwzględnieniem radiacji oraz powstawania zanieczyszczeń  $\text{NO}_x$  i  $\text{SO}_2$  prowadzono dla warunków spalania w powietrzu oraz przyjęto zróżnicowane atmosfery OXY. Obliczenia prowadzono w funkcji wartości współczynnika lambda oraz dla różnych wartości wilgotności paliwa.

**Słowa kluczowe:** modelowanie, Computational Fluid Dynamisc (CFD), spalanie pyłu węglowego, OXY, radiacyjny model spalania

Matúš PEŠKO<sup>1</sup> and Katarína KRÁĽOVÁ<sup>1</sup>

## PHYSIOLOGICAL RESPONSE OF *Brassica napus* L. PLANTS TO Cu(II) TREATMENT

### REAKCJA FIZJOLOGICZNA *Brassica napus* L. NA DZIAŁANIE MIEDZI(II)

**Abstract:** Rapeseed plants were exposed to seven different concentrations (0.5, 1, 3, 6, 12, 24, 60  $\mu\text{mol} \cdot \text{dm}^{-3}$ ) of  $\text{CuSO}_4 \cdot 5\text{H}_2\text{O}$  for 7 days. Within concentration range 0.5-3  $\mu\text{mol} \cdot \text{dm}^{-3}$  a significant increase of biomass (both plant organs) was observed. Decrease of biomass was notable after application of concentrations higher than 6  $\mu\text{mol} \cdot \text{dm}^{-3}$ . Considerable drop in content of chlorophylls as well as carotenoids was observed after application of 6  $\mu\text{mol} \cdot \text{dm}^{-3}$  Cu(II). Decline of protein content in leaves of plants was observed in concentration range 6-60  $\mu\text{mol} \cdot \text{dm}^{-3}$  Cu(II). Lipid peroxidation expressed as a content of malondialdehyde in leaves was strong within concentration range 6-60  $\mu\text{mol} \cdot \text{dm}^{-3}$  Cu(II). Bioaccumulation factor values of roots were higher than those of shoots in the whole concentration range (0.5-60  $\mu\text{mol} \cdot \text{dm}^{-3}$  Cu). The portion of Cu allocated in shoots related to the total Cu amount accumulated by plant ranged from 27.6% (0.5  $\mu\text{mol} \cdot \text{dm}^{-3}$ ) to 8.4% (60  $\mu\text{mol} \cdot \text{dm}^{-3}$ ).

**Keywords:** copper accumulation, bioaccumulation factor, lipid peroxidation, rapeseed

### Introduction

The content of Cu in the environment is usually low, but it is considerably increased in mining areas and in the vicinity of smelting plants. The usual content of Cu(II) ions in soils ranges from  $10^{-9}$  to  $10^{-4}$   $\text{mol} \cdot \text{dm}^{-3}$  [1, 2], but much of it is in forms which are not available to plants because of the strong binding of Cu by organic matter and other soil colloids [3].

Copper is an essential metal having important role in metabolic processes of plant cells. It is inevitable component of enzymes or of particular structural components of cells. At increased concentrations, Cu may have strong adverse effects on chromatin, the photosynthetic apparatus, growth and senescence processes [4]. Higher plant response to copper differs in mechanisms of its uptake and accumulation, and in the way of avoiding Cu-induced damage [5]. Visual symptoms of Cu toxicity depend strongly on plant growth stage at which the metal was applied. After a longer exposure to Cu (throughout the vegetation period) leaf area and content of chlorophylls and carotenoids is reduced [6, 7]. A common feature of the action of excess Cu in most plants is the decrease in root mass [8]. Copper impairs cellular transport processes and dramatically changes the biochemical metabolism [9]. Already at low concentrations, Cu inhibits photosynthesis by interaction with some constituents of photosystem (PS) II and by the formation of Cu-chlorophylls, which are unsuitable for photosynthesis [10, 11].

Being a redox-active metal, Cu catalyzes the production of *reactive oxygen species* (ROS), such as superoxide ( $\text{O}^{2-}$ ), hydrogen peroxide ( $\text{H}_2\text{O}_2$ ) and hydroxyl radicals ( $\text{OH}^*$ ), via Haber-Weiss and Fenton reactions [12]. ROS are damaging to essential cellular components such as DNA, proteins and lipids, therefore induction of ROS production results in oxidative stress affecting plant growth and alteration of antioxidant system [13].

<sup>1</sup> Faculty of Natural Sciences, Comenius University Bratislava, Mlynská dolina CH-2, SK-842 15 Bratislava, Slovakia, email: pesko@fns.uniba.sk

Plants have developed complex defence mechanisms by which they mediate the deleterious effects of the ROS. Such defence systems involve both enzymatic and non-enzymatic antioxidants. The enzymatic protective mechanism operates by sequential and simultaneous action of a number of antioxidant enzymes such as catalase, superoxide dismutase, ascorbate peroxidase, guaiacol peroxidase and glutathione reductase [14].

Rapeseed (*Brassica napus* L. *subsp. napus*) belonging to Brassicaceae family is known to be able to accumulate substantial amounts of metals; moreover, this plant has a high biomass and various genotypes are easily available [15].

The aim of this study is to investigate the effect of Cu(II) on plant biomass as well as Cu accumulation and translocation in plant organs of hydroponically cultivated *B. napus* plants (cv. Verona). Furthermore, content of soluble proteins, malondialdehyde (MDA), chlorophyll *a* and *b* as well as carotenoids in leaves was determined.

## Material and methods

For experiments  $\text{CuSO}_4 \cdot 5\text{H}_2\text{O}$  of analytical purity (Slavus, Bratislava) and seeds of *B. napus*, cv. Verona (Centre for Research of Crop Production, Research Institute of Crop Production, Piestany) were used. Twenty-two days old rapeseed plants were exposed in hydroponics for seven days in controlled conditions (mean air temperature:  $(25 \pm 0.5)^\circ\text{C}$ , relative air humidity: 80% and photosynthetic active radiation:  $80 \mu\text{mol} \cdot \text{m}^{-2} \cdot \text{s}^{-1}$ ): control variant in Hoagland solution and metal-treated variants in Hoagland solution containing 0.5, 1, 3, 6, 12, 24 and  $60 \mu\text{mol} \cdot \text{dm}^{-3}$   $\text{CuSO}_4 \cdot 5\text{H}_2\text{O}$ . Then the length and dry mass of shoots and roots were determined. Flame atomic absorption spectroscopy (AAS Perkin Elmer Model 1100, USA) was used for determination of Cu content in shoots and roots of rapeseed plants. Protein content in leaves was determined according to Bradford [16] and the content of malondialdehyde in leaves was determined as a content of thiobarbituric acid reactive substances (TBARS) [17] (the corresponding procedures are described in detail in [18]). Photosynthetic pigments were determined spectrophotometrically (Genesys 6, Thermo Scientific, USA) after extraction into 80% acetone [19].

## Results and discussion

Chlorosis of leaves of three-weeks old *B. napus* plants submitted to Cu stress for 7 days was notable at moderate applied Cu(II) concentrations ( $12$  and  $24 \mu\text{mol} \cdot \text{dm}^{-3}$ ). At the highest used concentration ( $60 \mu\text{mol} \cdot \text{dm}^{-3}$ ) was chlorosis more pronounced and all plants were stunted, some leaves were wilted and desiccated. Two highest applied concentrations of Cu(II) ( $24$  and  $60 \mu\text{mol} \cdot \text{dm}^{-3}$ ) caused that roots of plants were subtle and brownish.

Shoot and root dry mass as well as length of both plant organs of rapeseed plants treated with Cu(II) are summarized in Table 1. Within concentration range  $0.5$ - $3 \mu\text{mol} \cdot \text{dm}^{-3}$  a significant increase of dry biomass (both plant organs) was observed. This positive effect was most pronounced after application of  $0.5 \mu\text{mol} \cdot \text{dm}^{-3}$  Cu(II) as the gain of biomass of leaves and roots related to the control was 17% and 25%, respectively. Lin et al [20] and Jiang et al [21] observed similar increase of biomass in their experiments with *Helianthus annuus* L. and *Zea mays* L. plants treated with low Cu(II) concentrations ( $10^{-5} \text{mol} \cdot \text{dm}^{-3}$ ). Significant decrease of biomass of both plant organs was observed within

concentration range 6-60  $\mu\text{mol} \cdot \text{dm}^{-3}$ . In the concentration range of 6-24  $\mu\text{mol} \cdot \text{dm}^{-3}$  Cu(II) root length was affected by metal treatment to a greater extent than that of shoot. On the other hand, at the highest applied concentration (60  $\mu\text{mol} \cdot \text{dm}^{-3}$ ) the length of shoots was affected more than that of roots. Although some authors consider that inhibition of the cell cycle is the basis for growth inhibition, the precise role of Cu in cell proliferation is as yet unknown and controversial. Copper may affect cell wall building by direct affecting the crosslinking of hydroxyproline-rich protein cell wall components [4] due to high reactivity of Cu(II) with amino acids. Some divalent ions (especially Mg(II) and Ca(II)), in relation to their concentration, inhibit or enhance plant growth. Mg and Ca have similar chemical ionic form as Cu and for this reason the competitive action of these elements may be possible in the phase of uptake and transport modifying in consequence plant growth [22].

Table 1

Shoot and root length and dry mass of rapeseed plants treated with different concentrations of Cu(II). Mean  $\pm$  S.E.,  $n = 5$ . Means followed by different letters are significantly different at the 0.05 probability level

$c$ [ $\mu\text{mol} \cdot \text{dm}^{-3}$ ]	Shoot dry mass [mg]	Root dry mass [mg]	Shoot length [cm]	Root length [cm]
0	709.8 $\pm$ 9.4 <sup>cd</sup>	48.1 $\pm$ 2.5 <sup>bc</sup>	313.5 $\pm$ 3.9 <sup>ab</sup>	218.0 $\pm$ 6.3 <sup>a</sup>
0.5	828.0 $\pm$ 31.9 <sup>a</sup>	60.6 $\pm$ 2.0 <sup>a</sup>	325.3 $\pm$ 2.0 <sup>a</sup>	218.0 $\pm$ 6.1 <sup>a</sup>
1	745.0 $\pm$ 18.6 <sup>bc</sup>	49.5 $\pm$ 2.3 <sup>b</sup>	318.5 $\pm$ 5.4 <sup>ab</sup>	212.3 $\pm$ 5.2 <sup>a</sup>
3	784.3 $\pm$ 23.0 <sup>ab</sup>	49.9 $\pm$ 0.3 <sup>b</sup>	312.3 $\pm$ 9.8 <sup>ab</sup>	212.5 $\pm$ 4.2 <sup>a</sup>
6	655.5 $\pm$ 17.3 <sup>dc</sup>	44.2 $\pm$ 1.3 <sup>c</sup>	304.0 $\pm$ 4.6 <sup>b</sup>	192.5 $\pm$ 2.4 <sup>b</sup>
12	624.8 $\pm$ 18.4 <sup>c</sup>	37.8 $\pm$ 2.2 <sup>d</sup>	284.0 $\pm$ 8.6 <sup>c</sup>	189.5 $\pm$ 4.0 <sup>b</sup>
24	457.5 $\pm$ 10.8 <sup>f</sup>	29.5 $\pm$ 2.2 <sup>e</sup>	271.8 $\pm$ 8.4 <sup>c</sup>	186.8 $\pm$ 6.4 <sup>b</sup>
60	282.0 $\pm$ 22.9 <sup>g</sup>	16.0 $\pm$ 1.5 <sup>f</sup>	217.5 $\pm$ 5.6 <sup>d</sup>	179.0 $\pm$ 3.6 <sup>b</sup>

Contents of chlorophyll *a*, *b* and carotenoids in leaves of rapeseed plants are summarized in Table 2. Significant decrease in the content of chlorophylls and carotenoids was notable after application of 6  $\mu\text{mol} \cdot \text{dm}^{-3}$  Cu(II). Within concentration range 3-60  $\mu\text{mol} \cdot \text{dm}^{-3}$  was the content of chlorophyll *b* affected the most. Effect of copper on chlorophyll synthesis may be caused by inhibitory influence of Cu at the stage of  $\delta$ -aminolevulinic acid formation. Also a direct Cu effect is possible, through inhibition of Fe uptake which is indispensable for chlorophyll formation [4, 8].

Dependence of protein (Fig. 1A) and MDA (Fig. 1B) content in leaves of rapeseed plants on the applied Cu(II) concentration has bi-linear course. A rapid decline of protein content was observed in the concentration range 6-24  $\mu\text{mol} \cdot \text{dm}^{-3}$ , application of higher Cu concentrations resulted in less sharp decrease. After application of 6  $\mu\text{mol} \cdot \text{dm}^{-3}$  Cu(II) the protein content in leaves dropped only by 6% in comparison with the control, while application of the highest Cu(II) concentration (60  $\mu\text{mol} \cdot \text{dm}^{-3}$ ) caused about 48% decrease in protein content.

Copper induced oxidative stress in rapeseed plants was evident from the increased lipid peroxidation (content of MDA, Fig. 1 B) in leaves. In the concentration range of 0-3  $\mu\text{mol} \cdot \text{dm}^{-3}$  Cu(II) only mild increase in MDA content was observable but further increase of Cu(II) concentration caused sharp gain of malondialdehyde in leaves of rapeseed plants. At the concentration 60  $\mu\text{mol} \cdot \text{dm}^{-3}$  Cu(II) the content of this substance three times exceeded

that of the control. This finding is in agreement with the results of other studies carried out with rice plants cultivated in hydroponics [23, 24].

Excess Cu can induce a number of free radical processes in protein and lipid cell membrane components, causing destabilization of membranes and increase of their permeability. Polypeptide components of membranes can also be modified through Cu action on genetic material [4].

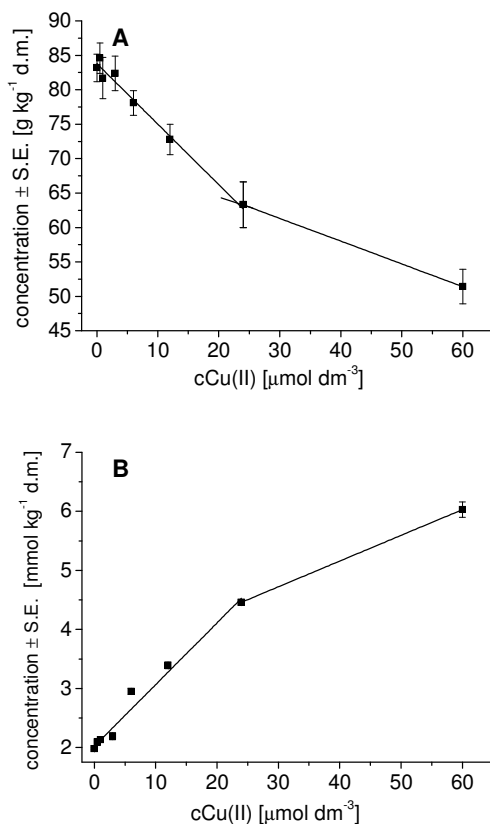

Fig. 1. Effect of applied Cu(II) concentration on protein (A) and MDA (B) content in leaves of rapeseed plants. Mean  $\pm$  S.E.; n = 5; d.m. - dry mass; S.E. - standard error

Heavy metal toxicity is considered to induce the production of reactive oxygen species and may result in significant damage to cellular constituents. Membrane lipids and proteins are especially sensitive to attack by free radicals and they are considered to be reliable indicators of oxidative stress in plants [25, 26].

Copper is taken up by higher plants largely in the form of Cu(II) ions due to the action of still not well-known mechanisms. For its absorption from rhizosphere probably the

functioning of Fe-dependent reductase is necessary. In its further transport phase, a significant role may be played by nicotinamide [4].

Table 2

Chlorophyll *a*, chlorophyll *b* and carotenoids contents in leaves of rapeseed plants treated with different concentrations of Cu(II). Mean  $\pm$  S.E.,  $n = 5$ . Means followed by different letters are significantly different at the 0.05 probability level; d.m. - dry mass

Cu(II) conc. [ $\mu\text{mol} \cdot \text{dm}^{-3}$ ]	Chl <i>a</i> conc. [ $\text{g} \cdot \text{kg}^{-1}$ d.m.]	Chl <i>b</i> conc. [ $\text{g} \cdot \text{kg}^{-1}$ d.m.]	Carot. conc. [ $\text{g} \cdot \text{kg}^{-1}$ d.m.]
0	17.6 $\pm$ 0.7 <sup>a</sup>	5.2 $\pm$ 0.4 <sup>a</sup>	5.7 $\pm$ 0.1 <sup>a</sup>
0.5	17.8 $\pm$ 0.2 <sup>a</sup>	5.3 $\pm$ 0.5 <sup>a</sup>	5.6 $\pm$ 0.1 <sup>a</sup>
1	17.6 $\pm$ 0.2 <sup>a</sup>	5.3 $\pm$ 0.4 <sup>a</sup>	5.5 $\pm$ 0.1 <sup>a</sup>
3	17.0 $\pm$ 0.5 <sup>a</sup>	5.0 $\pm$ 0.4 <sup>a</sup>	5.1 $\pm$ 0.1 <sup>b</sup>
6	15.9 $\pm$ 0.5 <sup>b</sup>	4.5 $\pm$ 0.2 <sup>ab</sup>	5.0 $\pm$ 0.3 <sup>b</sup>
12	12.5 $\pm$ 0.2 <sup>c</sup>	3.6 $\pm$ 0.3 <sup>bc</sup>	3.9 $\pm$ 0.1 <sup>c</sup>
24	10.0 $\pm$ 0.1 <sup>d</sup>	2.9 $\pm$ 0.3 <sup>c</sup>	3.3 $\pm$ 0.1 <sup>d</sup>
60	6.6 $\pm$ 0.2 <sup>e</sup>	1.8 $\pm$ 0.1 <sup>d</sup>	2.1 $\pm$ 0 <sup>e</sup>

Content of Cu in shoots and roots of rapeseed plants treated with different metal concentrations, the corresponding bioaccumulation (BAF) and translocation (TF) factors as well as the fraction of Cu allocated in shoots related to the total amount of Cu accumulated by plants are summarized in Table 3.

Table 3

Copper concentrations in shoots and roots of rapeseed plants treated with different concentrations of Cu(II), corresponding values of bioaccumulation (BAF) and translocation (TF) factors and fraction of Cu allocated in shoots related to the total amount of Cu accumulated by plants (in [%]); d.m. - dry mass

<i>c</i> [ $\mu\text{mol} \cdot \text{dm}^{-3}$ ]	Cu conc. [ $\text{mg} \cdot \text{kg}^{-1}$ d.m.]		TF [% Cu in shoot]
	BAF		
	Shoot	Root	
0.5	6.2	222.7	0.028
	<b>195.1</b>	<b>7009.1</b>	<b>27.6</b>
1	8.2	311.9	0.026
	<b>129.1</b>	<b>4908.3</b>	<b>28.4</b>
3	9.2	421.8	0.022
	<b>48.3</b>	<b>2212.6</b>	<b>25.5</b>
6	13.6	635.4	0.021
	<b>35.7</b>	<b>1666.5</b>	<b>19.5</b>
12	18.5	1255	0.015
	<b>24.3</b>	<b>1645.8</b>	<b>19.6</b>
24	19.8	2870	0.007
	<b>13</b>	<b>1881.8</b>	<b>9.7</b>
60	47.9	9249	0.005
	<b>12.6</b>	<b>2425.8</b>	<b>8.4</b>

Bioaccumulation factor (BAF) express the ratio of the metal concentration in the biological material [ $\mu\text{mol} \cdot \text{g}^{-1}$  or  $\mu\text{g} \cdot \text{g}^{-1}$  dry mass] to the metal concentration in external solution in [ $\mu\text{mol} \cdot \text{dm}^{-3}$  or  $\mu\text{g} \cdot \text{dm}^{-3}$ ]. In the whole concentration range 0.5-60  $\mu\text{mol} \cdot \text{dm}^{-3}$  Cu BAF values of roots were higher than those of shoots. Low values of BAFs determined for shoots reflect less effective mobility of Cu within the plant. The translocation factor

corresponds to the ratio of accumulated Cu amount in shoots and roots. Translocation factor values lower than 1 correspond to lower Cu concentration ( $\text{mg} \cdot \text{kg}^{-1}$  dry mass) in the shoots than in the roots.

The total Cu content occurring in individual plant organs is affected not only by Cu concentrations in shoots and roots but also by actual dry mass of these plant organs. After application of 0.5, 1 and 3  $\mu\text{mol} \cdot \text{dm}^{-3}$  Cu(II) portion of Cu allocated in shoots was over 20%.

Treatment with higher Cu(II) concentrations (24 and 60  $\mu\text{mol} \cdot \text{dm}^{-3}$ ) caused that this portion was under 10% (Table 3). The dependence of accumulated Cu content in shoots and roots on the applied Cu(II) concentration showed linear increase. The amount of Cu accumulated in roots was 36- to 193-times higher than in shoots. Greater Cu content in the roots than in the shoots of rapeseed plants may indicate adoption of exclusion mechanism to tolerate the copper-induced toxicity in which the roots accumulate the metal, preventing its subsequent transport into the shoots [13].

### Acknowledgements

This study was financially supported by Development fund of Comenius University in Bratislava under the contract No. UK/210/2012 and Sanofi Aventis Pharma Slovakia.

### References

- [1] Li Y, Wang Y, Gou X, Su Y, Wang G. *J Environ Sci.* 2006;18:1124-1134. DOI: 10.1016/S1001-0742(06)60050-8.
- [2] Marschner H. Function of mineral nutrients: Micronutrients. In: *Mineral Nutrition of Higher Plants*. 2nd ed. London: Academic Press; 2002:333-347.
- [3] Sanders JR, Adams TM, Christensen BT. *J Sci Food Agr.* 1986;37:1155-1164.
- [4] Dutta RK, Maharia RS. *Food Chem.* 2012;131:259-265. DOI: 10.1016/j.foodchem.2011.08.075.
- [5] Jiang WS, Liu DH, Hou WQ. *Bioresour Technol.* 2001;76:9-13.
- [6] Rousos PA, Harrison HC, Palta JP. *Hort Sci.* 1986;21:499-501.
- [7] Baszynski T, Tukendorf A, Ruzkowska M, Skórzynska E, Maksymiec W. *J Plant Physiol.* 1988;132:708-713.
- [8] Lindon FC, Henriques FS. *Photosynthetica.* 1992;154:130-135.
- [9] Hall JL. *J Exp Bot.* 2002;53:1-11.
- [10] Küpper H, Küpper F, Spiller M. *J Exp Bot.* 1996;47:259-266.
- [11] Peng H, Wang-Muller Q, Wilt T. *J Exp Bot.* 2012;79:58-65. DOI: 10.1016/j.envexpbot.2011.12.015.
- [12] Wang SH, Zhang H, Zhang Q, Jin GM, Jiang SJ, Jiang D, He QY, Li ZP. *J Agron Crop Sci.* 2011;197(6):418-429. DOI: 10.1111/j.1439-037X.2011.00476.x
- [13] Song-Hua W, Zhi-Min Y, Hong Y, Lu B, Shao-Qong L, Ya-Ping L. *Bot Bull Acad Sinica.* 2004;45:203-212.
- [14] Zabalza A, Galvez L, Marino D, Royuela M, Arrese-Igor C, Gonzalez EM. *J Plant Physiol.* 2008;165:805-812.
- [15] Wenzel WW, Unterbrunner R, Sommer P, Sacco P. *Plant and Soil.* 2003;249:83-96.
- [16] Bradford MM. *Anal Biochem.* 1976;72:248-254.
- [17] Heath RL, Packer L. *Arch Biochem Biophys.* 1968;125:189-198.
- [18] Peško M, Kráľová K, Blaško J. *Fresen Environ Bull.* 2012;21(3):761-768.
- [19] Lichtenthaler HK. *Methods Enzymol.* 1987;148:350-382.
- [20] Lin J, Jiang W, Liu D. *Bioresour Technol.* 2003;86:151-155.
- [21] Jiang W, Liu D, Liu X. *Biol Plant.* 2001;44(1):105-109.
- [22] Thimann KV, Biradivolu R. *Protoplasma.* 1994;183:5-9.
- [23] Thounaojam TCh, Panda P, Mazumdar P, Kumar D, Sharma GD, Sahoo L, et al. *Plant Physiol Biochem.* 2012;53:33-39. DOI: 10.1016/j.plaphy.2012.01.006.
- [24] Chen L, Lin ChCh, Kao ChH. *Bot Bull Acad Sin.* 2000;41:99-103.



- [25] Martínez-Peñalver A, Graña E, Reigosa MJ, Sánchez-Moreiras AM. Environ Exp Bot. 2012;78:1-9. DOI: 10.1016/j.envexpbot.2011.12.017.
- [26] Palma JM, Sandalio LM, Corpas FJ, Romero-Puertas MC, McCarthy I, del Rio LA. Plant Physiol Biochem. 2002;40:521-530.

### REAKCJA FIZJOLOGICZNA *Brassica napus* L. NA DZIAŁANIE MIEDZI(II)

**Abstrakt:** Rośliny rzepaku poddawano działaniu  $\text{CuSO}_4 \cdot 5\text{H}_2\text{O}$  w siedmiu różnych stężeniach (0,5, 1, 3, 6, 12, 24,  $60 \mu\text{mol} \cdot \text{dm}^{-3}$ ) przez 7 dni. W zakresie stężeń  $0,5\text{-}3 \mu\text{mol} \cdot \text{dm}^{-3}$  zaobserwowano znaczny wzrost biomasy (obie części roślin). Zmniejszenie biomasy zauważono po zastosowaniu wyższych stężeń niż  $6 \mu\text{mol} \cdot \text{dm}^{-3}$ . Znaczący spadek zawartości chlorofili oraz karotenoidów stwierdzono po zastosowaniu  $6 \mu\text{mol} \cdot \text{dm}^{-3}$  Cu(II). Spadek zawartości białka w liściach roślin zaobserwowano w zakresie stężeń  $3\text{-}60 \mu\text{mol} \cdot \text{dm}^{-3}$ . Peroksydacja lipidów wyrażona zawartością dialdehydu malonowego w liściach była silna w zakresie stężeń  $6\text{-}60 \mu\text{mol} \cdot \text{dm}^{-3}$  Cu(II). Wartości współczynnika bioakumulacji w korzeniach była większe niż w pędach w całym zakresie stężeń ( $0,5\text{-}60 \mu\text{mol} \cdot \text{dm}^{-3}$  Cu). Stosunek Cu zakumulowanej w pędach do całkowitej ilości miedzi zakumulowanej przez rośliny mieścił się w zakresie od 27,6% ( $0,5 \mu\text{mol} \cdot \text{dm}^{-3}$ ) do 8,4% ( $60 \mu\text{mol} \cdot \text{dm}^{-3}$ ).

**Słowa kluczowe:** akumulacja miedzi, współczynnik bioakumulacji, peroksydacja lipidów, rzepak



Michał RYMS<sup>1</sup>, Witold M. LEWANDOWSKI<sup>1</sup>, Ewa KLUGMANN-RADZIEMSKA<sup>1</sup>  
Katarzyna JANUSZEWICZ<sup>1</sup> and Krzysztof CIUNEL<sup>1</sup>

## METHODS OF LIQUID BIOFUEL PRODUCTION - THE BIOETHANOL EXAMPLE

### METODY PRODUKCJI BIOPALIW CIEKŁYCH NA PRZYKŁADZIE BIOETANOLU

**Abstract:** Ethanol is used in chemical and food industry, mainly either in the synthesis or as a solvent. The newest application of ethanol is as a fuel. This alcohol, produced on an industrial scale from crop waste, is widely known under the name bioethanol. It could be used as a fuel by itself or in a mixture with gasoline. Today, there are several technologies for bioethanol production known. The relatively simple method of obtaining bioethanol is through the mechanism of fermentation. There is an interest in use and improvement of this and other production mechanisms. Given the increasing demand for alternative fuels, ethanol today is one of the most supported research and implementation issues in the fuel sector. This paper summarizes the current knowledge on the subject. In this article, data from the largest producers of ethanol in the world and an analysis of use of biofuels in each country are presented. Identified characteristics of bioethanol production and its mechanism for the main technologies of production are presented. The paper contains a forecast on the future use of biofuels - the construction of a new generation of biorefineries.

**Keywords:** biofuels, bioethanol, technology of production

#### Introduction

Ethanol is used in chemical and food industry, mainly in the synthesis or as a solvent. Its relatively new application is utilizing as a liquid fuel. In this case, the popular solution is to use ethanol as a supplement of gasoline, because of the fact that the pure ethanol can be used in specially modified engines. Bioethanol has excellent oxidizing properties, causes limited emission of toxic gases (such as carbon and nitrogen oxides) and increases the fuel's octane number. On the other hand, if we use addition of ethanol, it is necessary to use others compounds. They reduce its volatility and limited tribological properties of the fuel, in order to counteract increased friction and rapid wear of the engine [1].

Ethanol can be produced from crops containing both monosaccharides and polysaccharides. In Poland, the most amount of ethanol is derived from potatoes and ryes. In future ethanol could be made from cellulosic materials, especially waste materials [1]. Production of bioethanol is still developing, the main direction of research aims at developing new techniques, lowering productions costs, lowering environmental pollutions, activation of agriculture, and, in a larger scale, reduction of oil import.

Poland has a considerable amount of excess biomass and experience in ethanol production. However, there's a problem with insufficient amount of the existing distilleries and spirit plants. Therefore, thinking about the future use of ethanol as a fuel, requires construction of new plants.

---

<sup>1</sup> Gdansk University of Technology, ul. G. Narutowicza 11/12, 80-233 Gdańsk, phone 58 347 23 22, email: smyr@plusnet.pl

### **The world production of ethanol**

The world production of ethanol is about 31-33 mln m<sup>3</sup> (24.5-26 mln Mg), 93% of which is generated by alcohol fermentation, the rest through chemical synthesis. The main part of production is located in Brazil and USA (65%). In Asia, the percent of production is about 18% and in Europe - 15%. Nowadays, production of ethanol as a fuel covers 2/3 of total world production. In Brazil, 95% of ethanol in circulation is utilized in form of fuel, in USA over 60%, in EU only 5%.

The largest company in Europe, which produces bioethanol, is Spanish Abengoa. Other large companies include: French confectionery Tereos and German: Crop Energies AG and Südzucker. An important place in the ranking is reserved for SEKAB, a Swedish company specializing in bioethanol production technology from lignocellulose, utilizing wood waste from paper industry (pulp), and excess of alcohol (wine). The guidance of the European Commission, which adjudicated on the possibility of managing the surplus of the product in the wine industry, encouraged company to use in the production wine stocks. SEKAB planned for 2008, invest in the production of bioethanol in Hungary. The plan was to build a four modern bioethanol plants for 380 million Euros, with a total production of 600 million liters (raw materials are mainly maize and wheat). By-product of this is over 460 000 Mg of animal feed [2]. Unfortunately, market verified the plans. The increasing prices of raw materials (cereals) in combination with reduced harvest of corn in Hungary (compared with the expected), also possibility of changes in European Union standards (for biocomponent), effectively discouraged investors. The company projects SEKAB are suspended due to lack of funds and so far there's little possibility to change this situation [4]. Hungary is now forced to cover their demand for bioethanol imports from Slovakia. SEKAB currently focused on promoting the new E-tech technology-based on bioethanol production from cellulose. The first stage of the raw material is subject to dilute acid (sulfuric acid or sulfur dioxide) and heat, which converts hemicellulose into sugar [5]. Other parts of the process are similar to any other processes of bioethanol production from lignocellulose.

The country, which strongly promotes the use of hydrated ethanol, is Brazil where pure ethanol is available at 26 thousand different fuel stations. The total number of cars, which are modified to use ethanol is more than 3 million. In recent years in the USA a significant increase in sales of E10 fuel has been observed - but still it is only 12% of total sales of gasoline.

### **The characteristic of bioethanol**

Bioethanol is defined as 99% ethyl alcohol derived from biomass. In trade, as an alternative fuel, it can be used in pure form or as an additive to gasoline at different volume ratios. It is accepted that the name of bioethanol determining the percentage of ethanol in biofuel preceding them with the letter E (*eg* E 85). According to the European standard for diesel fuel (DIN EN 228), the ethanol concentration in gasoline may not exceed 5% (E5). The use fuel with higher levels of ethanol in the vehicle inaccessible to the bioethanol may result in the loss of warranty. Bioethanol has a higher (by almost 10 units) octane number than gasoline, this can improve engine performance by increasing the degree of compression in the cylinder, however the use of pure fuel - 95% ethanol - requires special

engine construction. The standard also permits the use of other additives in the form of ethyl-t-butyl ether (ETBE - 47% ethanol and 53% of isobutene) in an amount not exceeding 15%. ETBE has also a high octane number, and adding it to gasoline improves the resistance to explosive combustion. However, the raw material for the production of ETBE is also ethanol [6].

### Mechanism of alcoholic fermentation

One of the main methods of bioethanol production is a alcoholic fermentation, which is a hydrolytic decomposition of monosaccharides like: (glucose (honey), fructose (fruits), saccharose (beets, sugar cane)). Ethanol could be generated in a enzymatic decomposition of polysaccharides - starch (*eg* from corn and cereals) to monosaccharides in the hydrolysis process. Research is being conducted on a method of ethanol production from cellulose and hemicellulose from wood and straw. In this method, the raw materials are not food biomass but waste biomass and in future this production may become competitive to other technologies.

In the fermentation process, glucose is decomposed to alcohol and CO<sub>2</sub> by using yeast enzymes (zymase), according to the following reaction:

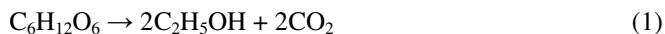

From a biochemical point of view, the alcoholic fermentation is a process of anaerobic sugar decomposition. This makes it possible for organism to thrive in anaerobic conditions (bacteria *eg* milk fermentation, cells of striated muscle in a effort, erythrocyte etc.). Alcoholic fermentation has three stages, one and two are similar like in milk fermentation - named glycolysis.

In the first stage, a glucose molecule, driven by ATP in the in the process of hexokinase, through gluco-6-phosphorane (glucose-fructose isomerase) is transformed with another ATP molecule into fructo-6-phosphorane which in turn causes the formation of 1,6-fructosediphosphate.

In the second stage, the diphosphat decomposes into 3-phosphogliceryne aldehyde or phosphodihydroxyacetone. These two compounds can be converted into each other by mechanism of tri-phosphate isomerase. The two molecules of 3-phosphogliceryne aldehyde undergo transformations involving oxidation and phosphorylation, and the reactions are accompanied by the creation of four molecules of ATP and two molecules of pyruvic acid (CH<sub>3</sub>COCOOH) [7, 8].

In the third stage, a decarboxylation of two molecules of pyruvic acid occurs, through pyruvate decarboxylase. From two molecules of acetaldehyde (CH<sub>3</sub>CHO) by alcoholic dehydrogenase with NAD, two molecules of ethyl alcohol are generated.



These three stages can be presented in simplified terms by cumulative reactions:

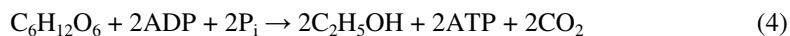

## Bioethanol production technologies

Fermentation of ethanol is one of the oldest techniques of biotechnology. It uses microorganisms, usually yeast: *Saccharomyces cerevisiae* capable of anaerobic conversion of monosaccharides to ethanol. The process of ethanol production can be divided into three main stages:

- preparation of raw material - enzymatic degradation of carbohydrate (starch, cellulose) into monosaccharides (glucose) by hydrolysis,
- ethanol fermentation - the processing of sugar conversion to alcohol, with emission of CO<sub>2</sub>,
- separation of the product - distillation, ethanol dehydration and rectification.

Two different methods of preparation of raw material - wet or dry milling are used in ethanol production on an industrial scale. Before the fermentation process is carried out, the wet process requires the separation of raw material (separately on the germ, fiber, protein and starch). In modern distilleries, the grinding process of raw materials is carried out, followed by their enzymatic hydrolysis. In older agricultural distilleries, fermentation is carried out periodically, which in case of the new fermentation processes has been replaced by continuous extraction with ethanol or diffuse discharges. The use of vacuum extraction of fermentation products provides higher efficiency. These methods, due to their high cost and complexity, are not applied on an industrial scale yet.

The fermentation of broth is the primary microbial process. The yeast are need to carry out processes - these include: *Saccharomyces cerevisiae* and *Saccharomyces carlsbergensis* in the upper fermentation, or *Saccharomyces bayanus*, wine yeast, baking, and wild yeast (a mixture of many cultures) in case of lower fermentation.

Yeast used in brewing ferment at low temperatures 5-10°C for about 1-2 weeks providing 2.5-5% vol. alcohol. Optimum fermentation temperature is 25-30°C and is used in distilling, where it takes 2-3 days, giving the mash content of 7-12% alcohol, but also a large amount of pollutants. Pollutants are disposed of by refining, rectification and using activated carbon adsorption. The turbulent and secondary fermentation of wine is carried out at lower room temperature, and therefore takes longer: 1-2 months (maturing for several years), but the resulting product has only trace amounts of fusion, giving it a special flavor and taste, specific for the vineyard.

Ethyl alcohol is separated from the fermentation residues using the distillation, and the boiling temperature difference using the two others components (ethanol boils at 78.3°C). Unfortunately, ethanol and water form an azeotrope mixture, which has a boiling point of 95.6% ethyl alcohol, about 4% water and the rest (higher alcohols, esters, ethers and acids). Even a small amount of water is unacceptable, because it can cause the presence of water in the fuel mixture. Therefore, only anhydrous alcohol (99.5-99.9%) should be used as a fuel.

The agricultural distilleries are used as distillation columns, designed for continuous work, the shelves separate raw spirit of broth digestate [9].

In distilleries, a 95.6% mixture of ethanol and water is produced, commonly known as spirit. It is in fact an azeotropic mixture and the pure ethanol could not be generated from it. In order to obtain the pure ethanol (100%), azeotropic distillation is conducted in the ethanol-water-benzene system. After adding a small amount of benzene, initially there is a threefold process of boiling azeotrope benzene-ethanol-water, then ethanol-benzene

azeotrope, and finally the process of distilling to pure anhydrous ethanol. It is possible to bound water with 95.6% ethanol by adding calcium oxide or anhydrous magnesium sulphate(VI) or sodium sulphate(VI). Absolute ethanol is hygroscopic and absorbs water from the air, so it should be stored in hermetic containers. Completely anhydrous ethanol (water content < 100 ppm) is obtained by distillation from over magnesium ethoxide in the system protected from air [10, 11].

The distillery produces low wine, containing about 90-92% ethanol. It is processed in rectification plants to the anhydrous or consumption alcohol. To obtain anhydrous alcohol, molecular sieves are used (sorption of water in a suitable sorbent) [1].

### *Iogen technology*

Bioethanol production technology proposed by Iogen company is based on a combination of thermal, biomass chemical and biochemical conversion into a fuel called cellulosic ethanol [12]. Cellulosic ethanol is produced in an amount of more than 340 liters per Mg of fiber.

Lignin, present in plant's fibers is processed and used as fuel for process steam and electricity. This eliminated the need of additional coal or natural gas, and also reduced CO<sub>2</sub> emissions. In the process of pretreatment, which is to increase the surface and "availability" of plant fibers to the enzymes, special water vapor injection systems are utilized. It improves the performance of both the pretreatment and ethanol production, which provide lower cost of the fuel. The company has also developed its own cellulose enzyme groups and delivers them worldwide to pulp, paper, textiles and animal feed industries.

### *ICM technology*

Technology adopted by ICM uses dry milling process in which grain is grinded for sharps. The starch contained in it is easier and faster converted into ethanol by fermentation process [13, 14].

Silos for the storage of grain are sufficient to supply the production line for 7-10 days. From the tray material goes to the hammer mills, preceded by a set of screens designed to remove residual stems, stones and ground, which could hinder the process of grinding. The ground grains are mixed with: process water (with pH of about 5.8) and enzyme ( $\alpha$ -amylase). The slurry is then heated to a temperature of 82-88°C for 30-45 minutes to reduce its viscosity and pumped pressurized steam injector, which also heats the mash to the 105°C. After 5 minutes, the mash is cooled in the tank with air at reduced pressure to a temperature of 82-88°C and left for 1-2 hours to make sugar from starch into short concatenation dextrin.

After the initial stage of saccharification and addition of a second enzyme - glucoamylase, the mash is pumped into fermentation tanks.

In the glucoamylase fermentation process, dextrin is broken down into simple sugars, then yeast is added, which provides the conversion of sugar into ethanol and carbon dioxide. The mash is allowed to ferment for 50-60 hours, resulting in the final mixture containing about 15% ethanol, also solid residues from grain and yeast. The fermented mash is pumped into the distillation columns, which provides additional warmth. Product leaving the distillation columns contains about 95% (by volume) ethanol. The residue from

this process (containing raw materials and water) is pumped from the bottom of the column to the centrifuges.

The resulting ethanol, containing still 5% of water, is directed to a molecular sieve to physically separate the water and ethanol, based on the difference in particle size between those substances. After going through this stage anhydrous ethanol is obtained. Small amounts of denatured alcohol are added before storage tanks. This contamination prevents distribution and use of this alcohol as a consumer product. Most of the tanks in the factory of ethanol are so capacious that they allow the storage of the product (as in the case of material) for 7-10 days.

The process of fermentative production of ethanol creates two by-products: carbon dioxide and stillage (cereal, potato). CO<sub>2</sub> can be captured and treated in a scrubber, and then launched to sold of agri-food processing, *eg* for aerating beverages. While the stock is headed to the centrifuges, where is separated into two fractions: a rare (liquid containing 5-10% solids) and a *thick wet solid residue* (WDG). Some of thin stillage is recycled to the process, which reducing the demand of process water. The rest is directed to a system of evaporators, where it is concentrated to a syrup having a concentration about 25-50%. This syrup, high in protein, yeast, sugar and fat, is used to enrich WDG. This could be perfect fodder for farm animals. Many bioethanol plants are not near the farmers to take advantage of all the WDG produced. Long term storage of such products is not a solution, because of the short life span of wet stillage (because of rapid biodegradation). In this case, the additional drying system is used, which removes moisture and prolongs its life span. Dry stillage (DDG) is used as high-protein feed ingredient of cattle, pigs, poultry and fish.

#### *Technology using supercritical water*

A new, exciting technology for the production of bioethanol is developed at Kyoto University [15]. Lignocellulose in biomass is subjected to the water in the supercritical state ( $T > 374^{\circ}\text{C}$ ,  $p > 22.1 \text{ MPa}$ ). The hydrothermal reaction of oxidative reforming, forming the fraction soluble in water and methanol, other soluble fraction only in methanol and lastly an insoluble residue. Hydrolysis products of carbohydrate derivatives, dehydrated, and shredded products and organic acids are the water-soluble substances. The residue is a mixture of glucan (polysaccharide) and lignin, which are insoluble in water, but are soluble in supercritical water, soluble in methanol part is derived from lignin.

The use of supercritical water allows the pretreatment of lignocellulose, involving the rupture of it long, chemically stable, chains for simple sugars, which are already subject to fermentation in the traditional production of ethanol [15].

The biomass resilient to ethanol fermentation (wood, straw, Lety, cake, *etc*), that contains lignocellulose is transported into reactor for hydrothermal decomposition with supercritical water. Products of hydrothermal decomposition, after the cold water addition, are pumped to the extractor, where the separation of water-soluble products from the methanol-soluble products occurs. The first of these fractions, containing products of cellulose and hemicellulose decomposition, is subjected to saccharification processes in an enzyme hydrolyser, then after the fermentation, distillation and rectification is generating the product which is bioethanol. The remaining, soluble in methanol, fraction containing aromatic compounds, derived from hydrothermal decomposition of lignin, is converted into



other useful products (solvents, intermediates and chemical reagents). A team of researchers from Kyoto is still conducting research to optimize this technology [16, 17].

Usefulness of water in the under or supercritical state as a solvent, reagent and catalyst of acid / alkaline in recent years is the subject of intensive research, which tends to use it in: chemical synthesis reactions, conversion processes, gasification, biomass processing, and wastewater treatment [18].

### **Biorafineries as a perspective for development of bioethanol**

Main research aiming at improving efficiency of bioethanol production is conducted in the following areas: raw material acquisition in form of waste or biomass, which does not undergo alcoholic fermentation, developing methods for pretreatment of biomass, the use of carbon dioxide and ammonia for decomposition of biomass and synthesis of more efficient enzymes.

In these studies, special emphasis was placed on the acquisition and use of more diverse material in the production of bioethanol, for example, waste from wood, crop residues, firewood from the forests, plants and municipal waste. The chemical structure of this potential raw material is much more diverse than traditional distilling material to which ethanol is the main source of starch or sugar. However, this requires solving many technological and chemical processes [19].

### **Summary**

In this study, a collection of examples of modern technologies allows obtaining ethanol has been presented. It systemizes knowledge in the field of liquid biofuels, based on the alcoholic fermentation. Proposed future solution, in the form of biorefineries is setting new trends and gives hope for further development and implementation of research in this area over the next decade.

### **References**

- [1] Szewczyk KW. Outline of the possibility of using ethanol as a renewable energy source. [In Polish] <http://www.mi.gov.pl/files/0/1791041/etanoljakoodnawialnerdoenergii.pdf>
- [2] Creating Markets for Renewable Energy Technologies European Renewable Energy Technology Marketing Campaign - Bioethanol Production and Use. Project: RESTMAC. [www.erec.org/fileadmin/erec\\_docs/.../Brochure5\\_Bioethanol\\_low\\_res.pdf](http://www.erec.org/fileadmin/erec_docs/.../Brochure5_Bioethanol_low_res.pdf)
- [3] Main actors in biodiesel and bioethanol production in the EU. Biofuels Platform. ENERS Energy Concept. <http://www.biofuels-platform.ch/en/infos/eu-actors.php>
- [4] BiofuelsDigest - news market. <http://www.biofuelsdigest.com/blog2/2008/03/19/sekab-cancels-hungarian-ethanol-project-citing-financing-30-hungarian-ethanol-projects-now-shelved/>
- [5] SEKAB. How We Make Ethanol. <http://www.sekab.com/cellulose-ethanol/e-tech-process>
- [6] Bioethanol - Press releases. <http://www.biomotion-tour.eu/>
- [7] FNR Biokraftstoffe 2007, FNR Biokraftstoffe Basisdaten Deutschland 2008. <http://www.nachwachsenderohstoffe.de/>
- [8] Kurcek A. Glykolysis. e-Biotechnologia.pl. <http://www.e-biotechnologia.pl/Artykuly/glikoliza/>
- [9] Alcoholic fermentation, e-Biotechnologia.pl, <http://www.e-biotechnologia.pl/Artykuly/Fermentacja-alkoholowa/>
- [10] Preparation of common solvents and reagents. Ethanol [In Polish]. <http://www.trimen.pl/witek/ciecz/rozpuszczalniki.html#etanol>
- [11] Vogel AI. Textbook of Practical Organic Chemistry. Warsaw: WNT; 1984
- [12] Iogen Corporation. [http://www.ioegen.ca/cellulosic\\_ethanol/what\\_is\\_ethanol/process.html](http://www.ioegen.ca/cellulosic_ethanol/what_is_ethanol/process.html)

- [13] Jakóbiec J, Wolszczak J. Prospects, barriers to growth and technical conditions for use of biofuels. Conference on Alter-Motive project. Poświętne: Nov. 4, 2010. <http://www.alter-motive.org/>
- [14] ICM Gasification Technology. [http://www.icminc.com/ethanol/production\\_process/](http://www.icminc.com/ethanol/production_process/)
- [15] Saka S, Phaiboonsilpa N, Nakamura Y, Masuda S, Lu X, Yamauchi K, Miyafuji H, Kawamoto H. Eco-Ethanol Production from Lignocellulosics with Hot-Compressed Water Treatment Followed by Acetic Acid Fermentation and Hydrogenolysis. The 31st Symposium on Biotechnology for Fuels and Chemicals. San Francisco, CA: May 3-6, 2009.
- [16] Phaiboonsilpa N, Lu X, Yamauchi K, Saka S. Chemical conversion of lignocellulosics as treated by two-step hot-compressed water. Green En Tech. 2010;III:166-170. DOI: 10.1007/978-4-431-99779-5\_25.
- [17] Ehara K, Saka S. Decomposition behavior of cellulose in supercritical water, subcritical water, and their combined treatments. J Wood Sci. 2005;51:148-153. DOI:10.1007/s10086-004-0626-2.
- [18] Pińkowska H, Wolak P, Złocińska A. Hydrothermal decomposition of alkali lignin in sub- and supercritical water. Chem Eng J. 2012;187:410-414. DOI: 10.1016/j.cej.2012.01.092.
- [19] Lewandowski WM, Ryms M. Biopaliwa - proekologiczne odnawialne źródła energii. Warsaw: WNT; Forthcoming; 2013.

## METODY PRODUKCJI BIOPALIW CIEKŁYCH NA PRZYKŁADZIE BIOETANOLU

Katedra Aparatury i Maszynoznawstwa Chemicznego, Politechnika Gdańska

**Abstrakt:** Etanol, poza wykorzystaniem w przemyśle spożywczym oraz chemicznym, gdzie służy jako rozpuszczalnik i substrat syntezowy, w ostatnich czasach zyskał również ważne zastosowanie w branży paliwowej. Produkowany jest na skalę przemysłową, głównie z substratów nienadających się do spożycia, i występuje pod zwyczajową nazwą bioetanol, pełniąc funkcję biopaliwa lub dodawanego do benzyny w różnych proporcjach biokomponentu. Z uwagi na stosunkowo prosty sposób produkcji, wykorzystujący mechanizm fermentacji, znanych jest dziś kilka technologii produkcji bioetanolu, a zainteresowanie ich wykorzystywaniem i ulepszaniem jest wciąż znaczne. Biorąc pod uwagę rosnące zapotrzebowanie na paliwa alternatywne, bioetanol jest dziś jednym z najbardziej nośnych tematów badawczych i wdrożeniowych w sektorze paliwowym. Niniejsza praca stanowi podsumowanie dotychczasowej wiedzy w tym obszarze. Przytoczono w niej dane, dotyczące największych producentów etanolu i bioetanolu na świecie oraz analizę wykorzystania tego biopaliwa w poszczególnych krajach. Przedstawiono charakterystykę bioetanolu, mechanizm jego produkcji i schematycznie zaprezentowano najważniejsze technologie produkcji. Praca zawiera również opis najbardziej prawdopodobnego przyszłego wykorzystania biopaliw - budowę biorafinerii nowej generacji.

**Słowa kluczowe:** biopaliwa, bioetanol, technologie produkcji

Zbigniew SUCHORAB<sup>1</sup>

## LABORATORY MEASUREMENTS OF MOISTURE IN A MODEL RED-BRICK WALL USING THE SURFACE TDR PROBE

### LABORATORYJNE POMIARY WILGOTNOŚCI W MODELOWEJ ŚCIANCE Z CEGŁY CERAMICZNEJ PEŁNEJ ZA POMOCĄ POWIERZCHNIOWEJ SONDY TDR

**Abstract:** The article presents the non-invasive attempt to moisture determination using the electric methods. The first part of the article describes the problem of moisture in the building barriers and the possibilities of its determination. The special attention is put on the electric methods of moisture determination. Second part of paper is experimental. For the experiment a model red-brick wall was built and prepared for water uptake process. The experiment was monitored by the capacitance and surface TDR probes which enabled to avoid the necessity of sampling or material destruction. Conducted experiments show the progress of water uptake phenomenon in the model wall and prove the potential of the non-invasive measurements using the surface TDR probes.

**Keywords:** capillary rise, red brick, surface TDR probes

#### Introduction

Water is one of the most important chemical compounds on Earth. It determines functioning of all living organisms. On the other hand its presence may lead to several problems, also connected to building objects functioning. Water presence in building materials is a common phenomenon. It occurs both in older buildings but also in modern objects, being the consequence of improper building works.

In the building barriers water may occur in three phases - solid, liquid and gaseous. Water presence in newly built objects is always connected to technology of materials production and building works. During their exploitation, the buildings may run dry or get wet, depending on external and internal conditions, but also the properties of the applied materials.

It has been noticed that chemically bound water does not influence moisture properties of the building barriers [1]. Also, water vapor presence is less influencing, comparing with the other types of water present in the building envelopes. The most meaningful is sorption and capillary water. The problem of water migration in building barriers is quite difficult to be described, mostly due to inhomogeneous structure of the materials and barriers, but also the fact that the particular elements like bricks or blocks are combined with mortar having completely different parameters from the main material. All above-mentioned problems cause serious problems for theoretical and experimental description of the mentioned phenomenon.

This paper is sacrificed to capillary rise phenomenon monitoring, which is considered to be a major cause of building destruction. One of the most popular building materials on Polish market is red ceramic brick which is especially popular in masonries and

---

<sup>1</sup> Faculty of Environmental Engineering, Lublin University of Technology, ul. Nadbystrzycka 40B, 20-618 Lublin, phone 81 538 43 22, email: Z.Suchorab@wis.pol.lublin.pl

substructures of many buildings. As a very popular building material it was used to build the model building barrier and then investigated for capillary uptake susceptibility.

For monitoring of moisture changes in the model barriers there were applied the FD (*Frequency Domain*) and modified TDR (*Time Domain Reflectometry*) methods, which enabled non-invasive moisture measurement in the porous materials.

FD method is a capacitance technique, which relies on the determination of condenser capacity. This method enables quick moisture determination with simple, user friendly mobile devices - Figure 1 which are non-invasive and do not require samples preparations.

The TDR method is a reflectometric technique which estimates dielectric permittivity of measured material by determining the velocity of signal propagation. The TDR which was successfully used for moisture determination of the soils [2-5] and building materials [6-8]. Until now the application of the TDR method for building materials was problematic due to the necessity of probes internal installation and was only possible to be applied in laboratory conditions mainly for soft building materials.

Since several years the surface TDR sensors are being developed and they seem to be perspective for non-invasive moisture determination in building materials and walls. Figure 2 presents the example of the surface TDR probe manufactured at Lublin University of Technology. Construction of the described sensor is presented in the following paper [9].



Fig. 1. Frequency Domain (capacitance) moisture meter (LAB-EL, Poland)



Fig. 2. Surface Time Domain Reflectometry probe (Lublin University of Technology)

## Materials and methods

Capillary rise phenomenon was examined in the model wall (Fig. 3) made of red ceramic brick with bulk density of  $1600 \text{ kg/m}^3$ . Bricks of the masonry were combined with cement mortar 10 mm wide. Particular bricks dimensions are the following:  $250 \times 120 \times 65 \text{ mm}$ . For the experiment it was applied the capacitance sensor and the

modified TDR probe which enabled non-invasive measurements of moisture processes inside the walls.



Fig. 3. Model wall made of red ceramic brick

Measuring setup, presented on Figure 4 consisted of:

- model wall placed in the water container,
- TDR multimeter (LOM/EasyTest, Lublin, Poland),
- surface TDR probe (Lublin University of Technology, Poland),
- PC computer as control station,
- LB-796 capacitance moisture meter (LAB-EL, Poland).

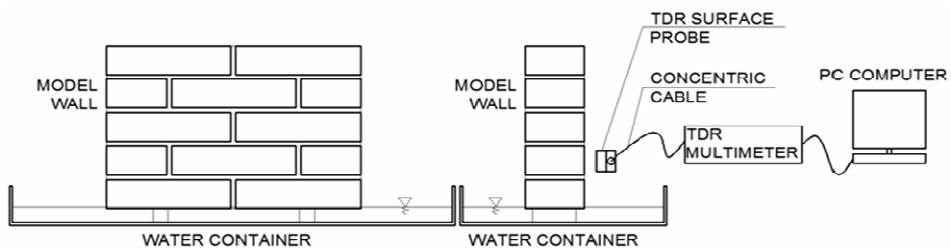

Fig. 4. Measuring setup

In such a prepared model wall, particular bricks were marked with the following symbols 1A, 1B, 2A, 2B, 2C, etc., where digit meant particular layer of the bricks. Such prepared wall was dried in 105°C and put into the water container with constant water level 10 mm above bottom edge of the measured wall. The wall was monitored for moisture changes by capacitance and the surface TDR sensors for period of 30 days with 24 hour intervals. The TDR instrumentation applied for the experiment enabled readouts of electromagnetic pulse propagation along the measuring elements of the surface probe, which were used for effective dielectric permittivity calculation (depending on surface sensor construction) and thus moisture. Calibration experiments were presented in [9, 10].

Capacitance probe was pre-calibrated by the device producer (LAB-EL, Poland) for most of typical building materials and enabled quick moisture measurement without the necessity to calibrate the sensor.

## Results

Basing on moisture readouts obtained by the capacitance and the surface TDR probe it was determined the dynamics of moisture increase due to capillary rise phenomenon in the model wall made of red ceramic brick. The process is presented at the below diagrams. Figure 5 represents the average data obtained by capacitance measurements, Figure 6 represents average data obtained by the TDR equipment with the application of the non-invasive, surface TDR sensor presented on Figure 2.

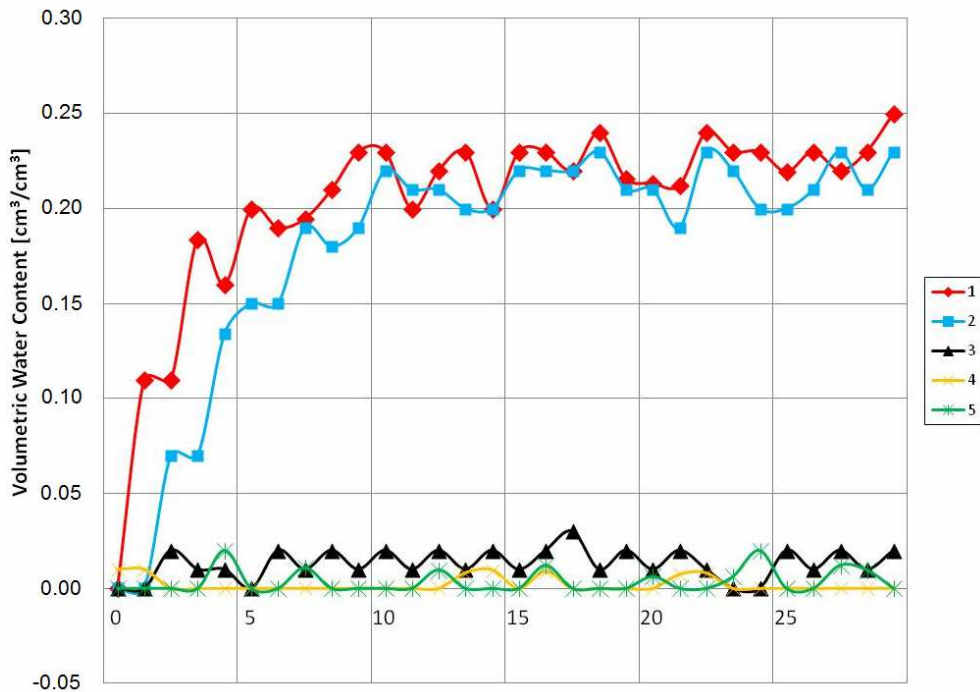

Fig. 5. Capillary rise phenomenon determined with capacitance probe

As a result of the conducted research it was confirmed high absorptivity of water by the red ceramic brick. At the bottom layer of the bricks water appeared soon after the experiment had started. Water content quickly risen, which is clearly visible at the lowest bricks. At bricks 2A, 2B and 2C of the second level, water appeared about one or two days later and after 8 days of process reached more than 20% vol., which was close to saturation. It must be underlined that no increase of water content was observed at layers 3, 4 and 5. This may be caused by several reasons. One of them is low permeability of cement mortar for water, which prevents water from rising to the higher layers. Another reason for that

phenomenon may be the drying process. Comparing with the other experiments [7], model wall was not insulated from external environment, and higher layers of the wall could be not available for water due to its desorption processes.

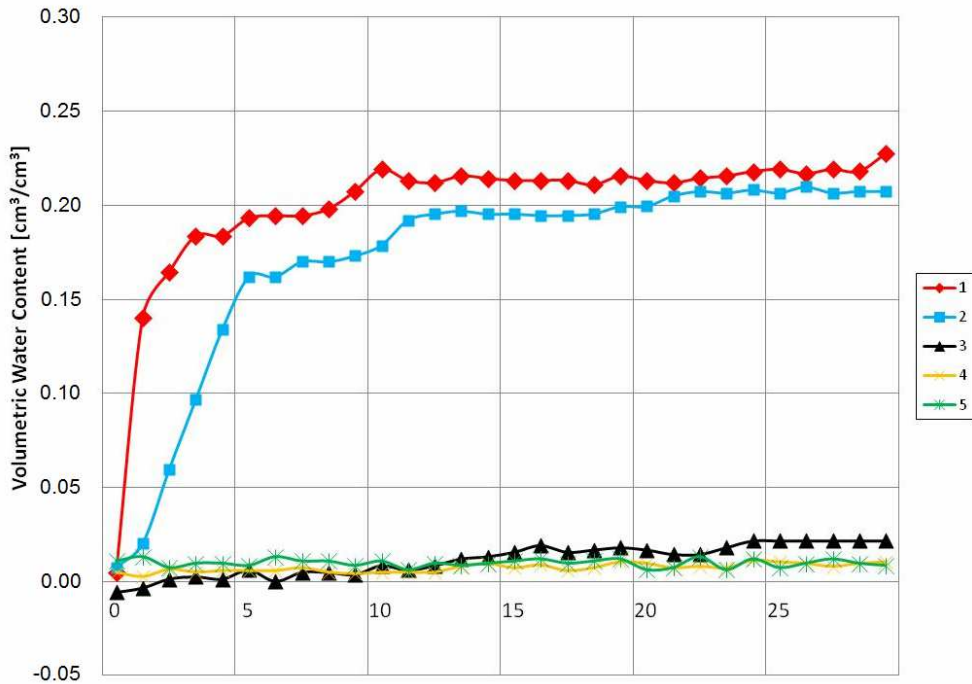

Fig. 6. Capillary rise phenomenon determined with surface TDR probe

Data obtained using the TDR technique comparing with capacitance results seems to be more stable. Capacitance readouts are fluctuating for about 4% vol. and the TDR readouts fluctuations do not exceed 2% vol. On the other side, it is possible that TDR moisture readouts may be underestimated for that material which maximum moisture, according to the producer, may reach 25% vol.

## Conclusions

- The experiment confirms the potential of the TDR technique for moisture processes monitoring in building materials. Application of the surface TDR probes enables quantitative determination of moisture changes in the material without the necessity of invasive probes installation, which may be successfully used *in in-situ* experiments.
- For capacitance probe readouts the dispersion was greater than in presented TDR measurements, which can be explained by the salinity influence on capacitance measurement.

- According to both methods, water uptake process was confirmed, especially in bottom layers of the wall, strongly exposed on water presence.

## References

- [1] Rokiel M. Hydroizolacje w budownictwie. Warszawa: Wyd Medium; 2006.
- [2] Topp GC, Davis JL, Annan AP. Electromagnetic determination of soil water content: Measurements in coaxial transmission lines. *Water Resour Res.* 1980;16:574-582. DOI: 10.1029/WR016i003p00574
- [3] Malicki MA, Plagge R, Roth CH. Improving the calibration of dielectric TDR soil moisture determination taking into account the solid soil. *Eur J Soil Sci.* 1996;47:357-366. DOI: 10.1111/j.1365-2389.1996.tb01409.x
- [4] Skierucha W, Malicki MA. TDR Method for the Measurement of Water Content and Salinity of Porous Media, Institute of Agrophysics. Lublin: Polish Academy of Sciences; 2004.
- [5] Suchorab Z, Sobczuk H, Rożej A, Łagód G. Comparison of Reflectometric and Gravimetric Methods for Examination of Sewage Sludge Additions Influence on Water Properties of Reclaimed Soils. *Ecol Chem Eng.* 2009;16(4):257-264.
- [6] Cerny R. Time-domain reflectometry method and its application for measuring moisture content in porous materials: A review. *Measurement.* 2009;42:329-336. DOI: 10.1016/j.measurement.2008.08.011
- [7] Suchorab Z, Jarmuła M, Sobczuk H, Pavlík Z, Černý R. Zastosowanie metody TDR do pomiaru podciągania kapilarnego w ścianie modelowej z cegły ceramicznej pełnej (In Polish). *Proc ECoPole.* 2009;3(1):207-213.
- [8] Guz Ł, Suchorab Z, Alcobia B, Sobczuk H. Wyznaczanie krzywej retencji wody materiałów porowatych za pomocą sond psychrometrycznych i TDR (In Polish). *Proc of ECoPole.* 2010;4(2):371-375.
- [9] Suchorab Z, Sobczuk H, Cerny R, Pavlík Z, Plagge R. Non-invasive moisture measurement of building materials using TDR method. *Proc. of the 8th International Conference on Electromagnetic Wave Interaction with Water and Moist Substances, June 1-5, Espoo, Finland;* 147-155.
- [10] Suchorab Z, Jedut A, Sobczuk H. Water content measurement in building barriers and materials using surface TDR probe. *Proc of ECoPole.* 2008;2(1):123-127.

## LABORATORYJNE POMIARY WILGOTNOŚCI W MODELOWEJ ŚCIANCE Z CEGŁY CERAMICZNEJ PEŁNEJ ZA POMOCĄ POWIERZCHNIOWEJ SONDY TDR

Wydział Inżynierii Środowiska, Politechnika Lubelska

**Abstrakt:** Artykuł przedstawia bezinwazyjny sposób pomiaru wilgotności z wykorzystaniem metod elektrycznych. W pierwszej części artykułu omówiono problem nadmiernego zawilgocenia przegród budowlanych i sposoby pomiaru tego zjawiska. Druga część pracy ma charakter eksperymentalny. Przygotowano modelową ściankę z cegły ceramicznej pełnej w celu zbadania zjawiska podciągania kapilarnego. Omawiany proces był monitorowany za pomocą czujników pojemnościowych oraz powierzchniowych sond TDR, co umożliwiło bezinwazyjne pomiary, niewymagające pobrania fragmentów muru lub innych ingerencji w badany materiał. Uzyskane wyniki pozwalają na śledzenie procesu podciągania kapilarnego w modelowej ścianie z cegły ceramicznej pełnej i potwierdzają możliwości sondy powierzchniowej TDR w pomiarach wilgotnościowych murów.

**Słowa kluczowe:** podciąganie kapilarne, cegła ceramiczna pełna, powierzchniowe sondy TDR



Maciej ZAWIŚLAK<sup>1</sup>

## IMPACT OF VEHICLE INTERIOR GEOMETRY ON CHOSEN VOLATILE CARCINOGENS CONCENTRATION DISTRIBUTION IN VEHICLE CABIN

### WPLYW GEOMETRII WEWNĘTRZNEJ POJAZDU NA ROZKŁAD STĘŻEŃ SUBSTANCJI KANCEROGENNYCH W ATMOSFERZE WNEŹRZA KABINY

**Abstract:** The phenomena of volatile carcinogens pollution of interior atmosphere is an important issue on public health field. A car vehicle is a specific environment of human life where levels of volatile compounds concentration are much higher than *ie* in buildings (houses or offices). The VOCs sources can be divided on external (polluted air inlet through vehicle ventilation system) an internal (emission from cabin equipment materials). The volatile organic compounds are absorbed by human body mostly by respiratory system. The significant impact on toxicological characteristic of in-vehicle VOCs, in parallel with physical-chemical properties of the substance and exposition time, has also concentration distribution in vehicle cabin, especially the concentration on user head level. In the paper the results of CFD simulation of cabin geometry impact on chosen VOCs (benzene and toluene) distribution is presented. The geometrical model of vehicle cabin has been made and its insignificant modification was conducted to proof cabin geometry impact on driver exposure on the carcinogens carried out by ventilation system.

**Keywords:** CFD modeling, vehicle interior, volatile organic compounds

#### Introduction

Many organic compounds are known to cause cancer in animals; some are suspected of causing, or are known to cause, cancer in humans [1]. From *volatile organic compounds* (VOC) group especially *BTX* (benzene-toluene-xylene and their isomers) have been classified as a human carcinogens by IARC (1982) and was listed by both the European Commission and the World Health Organization as one of the top-priority compounds for the development of guidelines for indoor air quality (EC JRC, 2005; WHO, 2006). As with other pollutants, the extent and nature of the health effect will depend on many factors including the level of exposure and length of time exposed.

Benzene concentrations measured in vehicles are generally higher than those outdoors. Levels of benzene measured in vehicles in Europe ranged from 13 to 42  $\mu\text{g}/\text{m}^3$ , while lower levels of 1.3-3.8  $\mu\text{g}/\text{m}^3$  were measured in a recent United Kingdom study [2]. Benzene levels measured in Mexico and the United States ranged from 1.7 to 42  $\mu\text{g}/\text{m}^3$  and a similar range (0.5-47  $\mu\text{g}/\text{m}^3$ ) was found in several Asian cities [3]. The highest in-vehicle benzene levels were measured in Italy in the early 2000s, with geometric means ranging from 17 to 101  $\mu\text{g}/\text{m}^3$  [3].

The aim of this study was Computational Fluid Dynamics simulation of cabin geometry impact on chosen VOCs (benzene, toluene and xylene) distribution is presented. The geometrical model of vehicle cabin has been made and its insignificant modification

---

<sup>1</sup> Institute of Machine Design and Operation, Faculty of Mechanical Engineering, Wrocław University of Technology, ul. Wybrzeże Wyspiańskiego 27, 50-370 Wrocław, phone 71 320 26 67, email: maciej.zawislak@pwr.wroc.pl

was conducted to proof cabin geometry impact on driver exposure on the carcinogens carried out by ventilation system.

## Methodology

As an object for modeling chosen aromatic compounds particle distribution geometry passenger-vehicle (Fiat Grande Punto) was chosen as an examples of basic geometry of popular car vehicle. Three-dimensional computational model of sampler was design in Gambit software (Fig. 1).

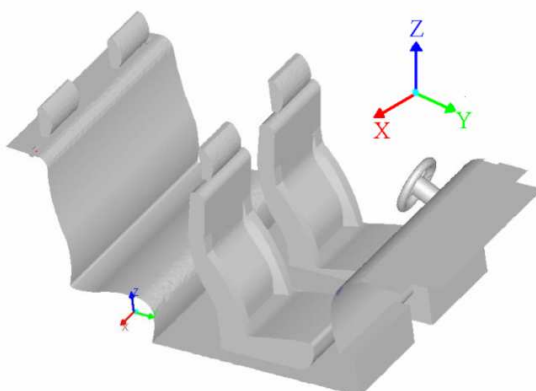

Fig. 1. Grande Punto geometry model (Gambit software)

For flow modeling application FLUENT-ANSYS software was applied. Numerical mesh on tetra elements was made. Two-equational  $k$ - $\epsilon$  turbulence model was applied. For particle of chosen VOCs modeling DPM model was used.

For simulations boundary conditions of benzene and toluene was based on chromatographic analysis on real object (Emission Research Laboratory, Varian 450GC-FID chromatograph) in a brand new passenger. The VOCs samples were up-taking in points set according to according to ISO/DIS 12219-1draft [4]. The temperature and pressure was kept in standard conditions of human existence (293 K, 101300 Pa).

The vehicle geometry was modified as in Table 1.

Geometry modifications variants

Table 1

Symbol	Geometry variant	Dimension		
		Width	Length	Height
B	Basic geometry	X	Y	Z
E1	Resized geometry (expanded): variant 1	X + 10%	Y	Z
E2	Resized geometry (expanded): variant 2	X	Y + 10%	Z
E3	Resized geometry (expanded): variant 3	X	Y	Z + 10%

## Boundary conditions

In Table 2 boundary conditions for simulation are presented:

Table 2

Boundary conditions for modeling	
Compounds concentration [kg/m <sup>3</sup> ]	
Benzene (and isomers)	$1.58 \cdot 10^{-6}$
Toluene (and isomers)	$3.14 \cdot 10^{-6}$
Flow set	
Flow intensity [m <sup>3</sup> /s]	$4.2 \cdot 10^{-4}$ m <sup>3</sup> /s
Ventilation system mode	Central ventilation nozzles

## Results

The results were presented in tables and figures below.

In Figure 2 the air stream lines are presented according to applied ventilation system set (Table 2).

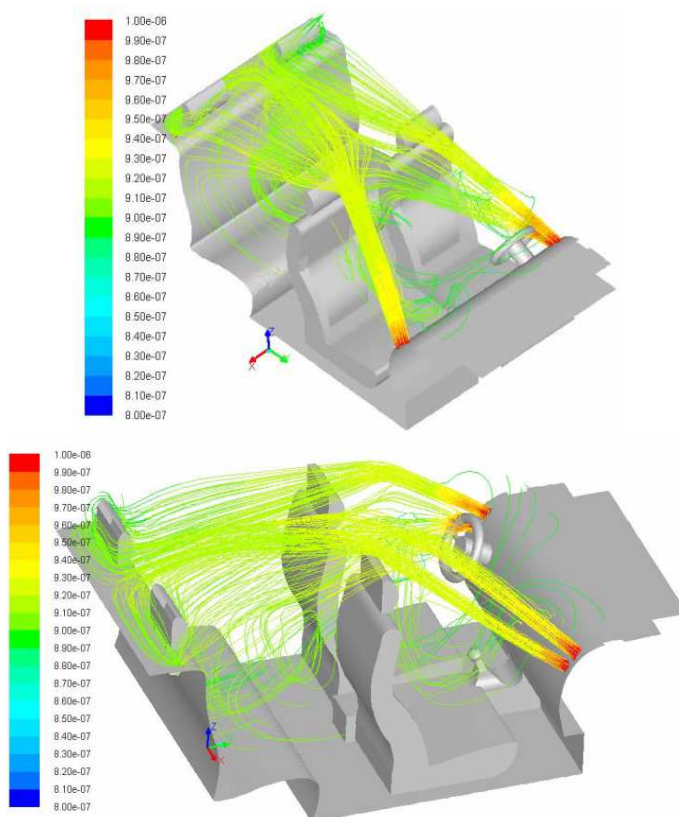
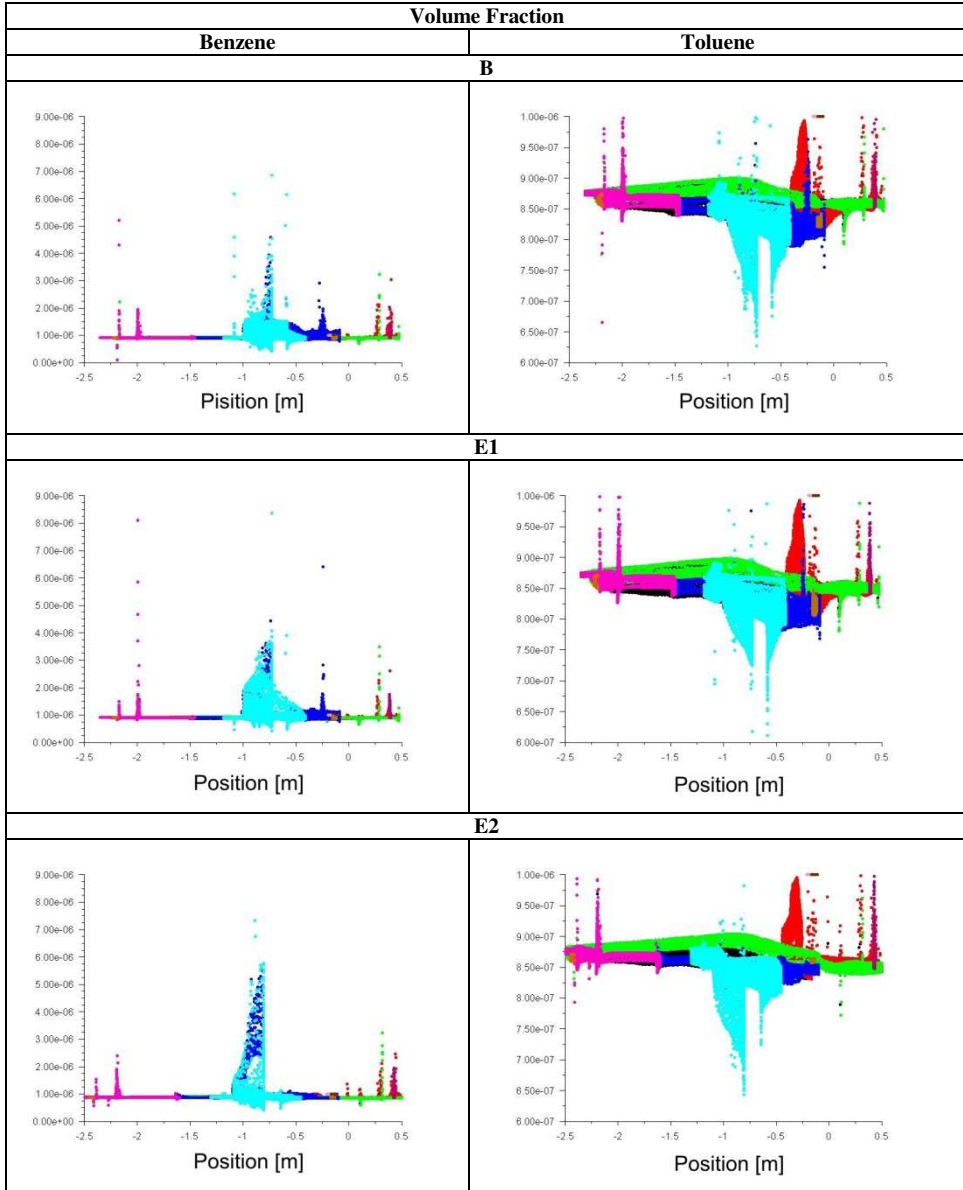

Fig. 2. Flow intensity stream lines [m<sup>3</sup>/s] (central nozzles mode)

In Table 3 the results of modeling - benzene and toluene concentration distributions in analyzed variants of geometry models are presented for all Y-Z cross-sections.

Table 3

Benzene and toluene volume fraction distribution on all Y-Z cross-sections



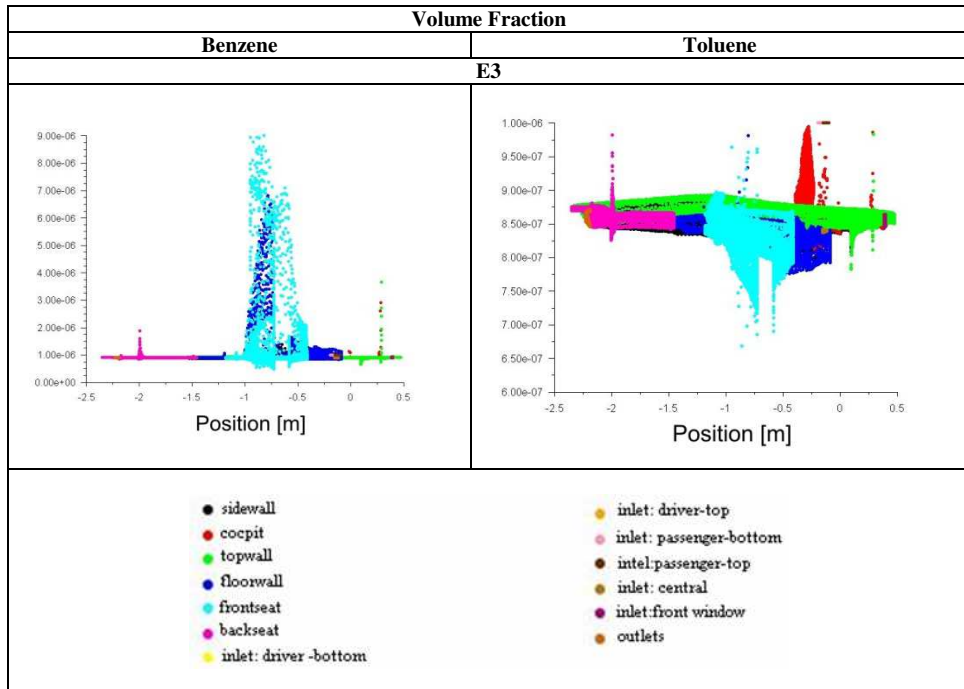

According to the modeling results it is visible that even insignificant (10% in one dimension) changes in vehicle geometry cause change in carcinogens distribution, especially for particular health-hazardous benzene.

For driver exposure investigation, as a most exposed vehicle user because of in-vehicle time residence, the cross-section on driver position (Fig. 3) was separately analyzed.

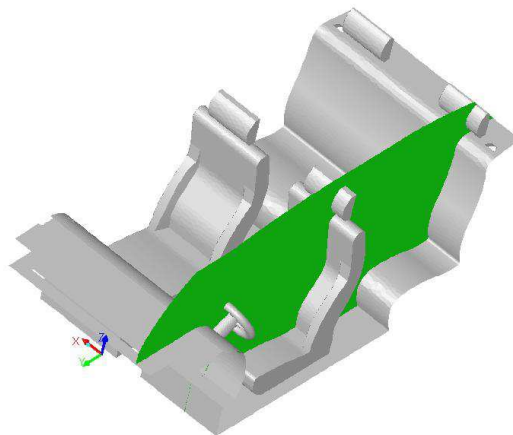
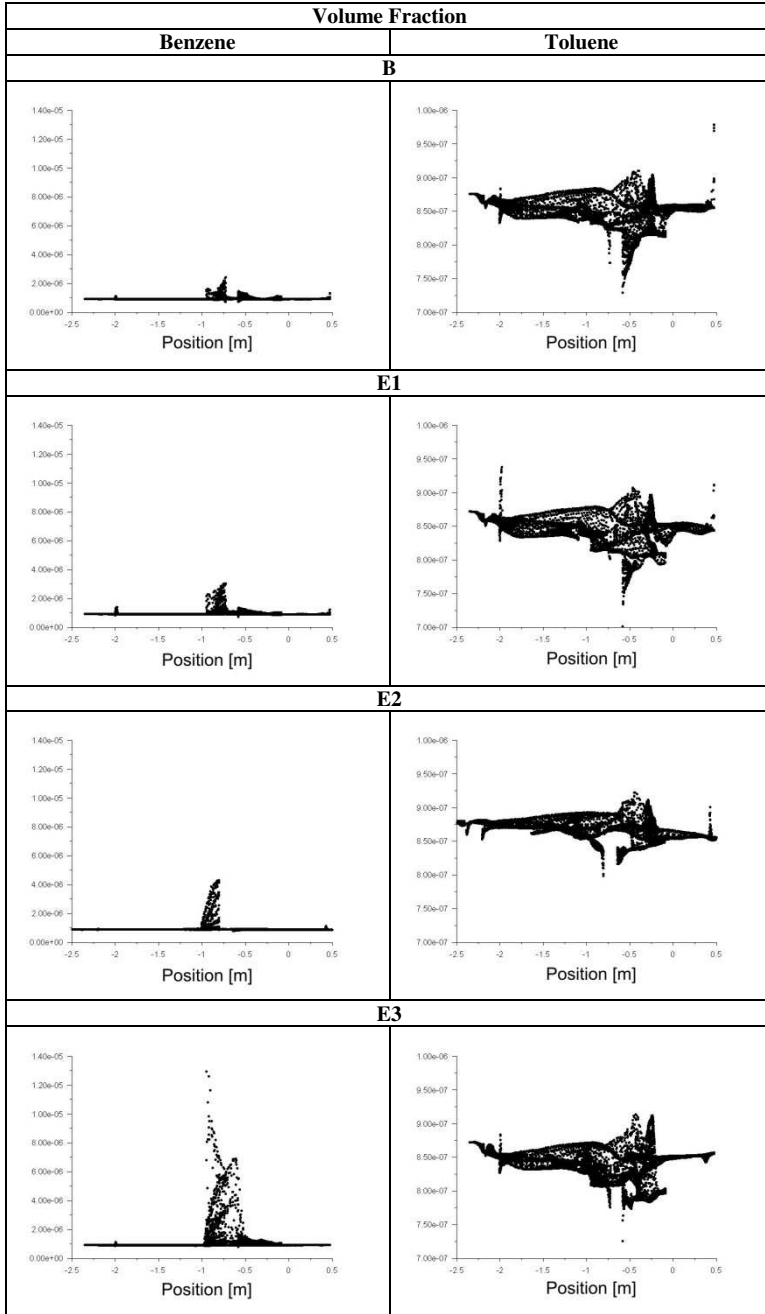

Fig. 3. Cross-section on driver position

Table 4

Benzene and toluene volume fraction distribution on driver position (according Fig. 3)



The results of the simulation on a cross-section on driver position are presented in Table 4.

The highest benzene concentration on driver position (frontseat) was observed in case E3 geometry variant (10% interior height expand). The basic variant seems to be most advantageous for benzene distribution. Analyzing toluene dispersal the most advantageous is E2 variant (10% extend of vehicle length). For both volatile compounds the impact of geometry change on carcinogens distribution is visible.

### Summary

To discuss the toxicological characteristic of in-vehicle VOCs, in parallel with physical-chemical properties of the substance and exposition time, also carcinogens concentration distribution in vehicle cabin, especially the concentration on user head level need to be consider. CFD modeling enable in a relative short time analyze different geometry variants of vehicle interior and evaluate their impact on volatile individuals distributions.

The paper presents results of the modeling of benzene and toluene distribution inside popular passenger car and the impact of insignificant interior geometry modifications on those compounds concentration. According to the simulations some conclusions should be emphasized:

- The analyzed geometry variations impact on benzene and toluene concentrations.
- The most advantageous variant in aspect of driver exposure seems to be basic variant (B) for benzene and 10% length expand variant (E2) for toluene.
- The results of the modeling indicate on its applicability to evaluate the vehicle user exposure on particular volatile carcinogens. The researches need to be expanded on more geometry modifications (also geometry reduction and mixed variants) for finding optimal variant of particular vehicle interior in aspect of human health exposure on VOCs carcinogens.

### References

- [1] Janicka A. Method of toxicity estimation of gaseous mixtures emitted from different emission sources. *Polish J Environ Stud.* 2012;21(5A);134-139.
- [2] Xiaozhen Liu H. Christopher Frey Modeling of in-vehicle human exposure to ambient fine particulate matter. *Atmospher Environ.* 2011;45:4745-4752. DOI: <http://dx.doi.org/10.1016/j.atmosenv.2011.04.019>.
- [3] WHO Guidelines for indoor air quality, Copenhagen Ø, Denmark, WHO Publications; 2010.
- [4] ISO/DIS 12219 (2011): Indoor air of road vehicles: Whole vehicle test chamber - Specification and method for the determination of volatile organic compounds in cabin interiors.

## WPLYW GEOMETRII WEWNĘTRZNEJ POJAZDU NA ROZKŁAD STĘŻEŃ SUBSTANCJI KANCEROGENNYCH W ATMOSFERZE WNĘTRZA KABINY

Instytut Konstrukcji i Eksploatacji Maszyn, Wydział Mechaniczny, Politechnika Wroclawska

**Abstrakt:** Obecność kancerogenów z grupy lotnych połączeń organicznych, w szczególności w pomieszczeniach zamkniętych, jest istotnym problemem z zakresu zagadnień w obszarze zdrowia publicznego. Pojazd samochodowy jest środowiskiem życia człowieka, w którym poziomy stężenie substancji z grupy lotnych połączeń organicznych znacznie przekraczają stężenia w budynkach mieszkalnych czy biurach. Źródła LZO (benzenu

i toluenu) w kabinie pojazdu można podzielić na dwa rodzaje: zewnętrzne (zanieczyszczone powietrze wprowadzane do wnętrza kabiny za pomocą systemu wentylacyjnego pojazdu) oraz wewnętrzne (emisja z materiałów stosowanych we wnętrzu kabiny pojazdu). Lotne związki organiczne przedostają się do organizmu ludzkiego głównie za pomocą dróg oddechowych, a na ocenę ich wpływu toksycznego na zdrowie użytkowników oprócz właściwości fizykochemicznych substancji oraz czasu ekspozycji ma również znaczący wpływ dystrybucja tych substancji we wnętrzu pojazdu, w szczególności ich koncentracja na wysokości głowy użytkownika. W niniejszym artykule zaprezentowano wyniki symulacji komputerowej (metoda CFD) cyrkulacji powietrza wewnątrz kabiny pojazdu w aspekcie rozkładu wybranych kancerogenów z grupy LZO. Wykonano model geometryczny kabiny pojazdu, a następnie poprzez nieznaczne modyfikacje geometrii wnętrza udowodniono wpływ geometrii na narażenie kierowcy na kontakt z lotnymi substancjami o charakterze kancerogennym wprowadzanymi poprzez system wentylacyjny pojazdu.

**Słowa kluczowe:** modelowanie przepływów, wnętrze pojazdu, lotne związki organiczne