

SOCIETY OF ECOLOGICAL CHEMISTRY AND ENGINEERING

**ECOLOGICAL CHEMISTRY
AND ENGINEERING A**

CHEMIA I INŻYNIERIA EKOLOGICZNA A

Vol. 18

No. 7

OPOLE 2011

EDITORIAL COMMITTEE

Witold Waclawek (University, Opole, PL) – Editor-in-Chief
Milan Kraitr (Western Bohemian University, Plzen, CZ)
Jerzy Skrzypski (University of Technology, Łódź, PL)
Maria Waclawek (University, Opole, PL)
Tadeusz Majcherczyk (University, Opole, PL) – Secretary

PROGRAMMING BOARD

Witold Waclawek (University, Opole, PL) – Chairman
Jerzy Bartnicki (Meteorological Institute – DNMI, Oslo-Blindern, NO)
Mykhaylo Bratychak (National University of Technology, Lviv, UA)
Bogusław Buszewski (Nicolaus Copernicus University, Toruń, PL)
Eugenija Kupcinskiene (University of Agriculture, Kaunas, LT)
Bernd Markert (International Graduate School [IHI], Zittau, DE)
Nelson Marmioli (University, Parma, IT)
Jacek Namieśnik (University of Technology, Gdansk, PL)
Lucjan Pawłowski (University of Technology, Lublin, PL)
Krzysztof J. Rudziński (Institute of Physical Chemistry PAS, Warszawa, PL)
Manfred Sager (Agency for Health and Food Safety, Vienna, AT)
Mark R.D. Seaward (University of Bradford, UK)
Jiří Ševčík (Charles University, Prague, CZ)
Piotr Tomasik (University of Agriculture, Krakow, PL)
Roman Zarzycki (University of Technology, Lodz, PL)
Tadeusz Majcherczyk (University, Opole, PL) – Secretary

EDITORIAL OFFICE

Opole University
ul. kard. B. Kominka 4, 45-032 OPOLE, PL
phone +48 77 455 91 49
email: waclawek@uni.opole.pl
<http://tchie.uni.opole.pl>

SECRETARIES

Agnieszka Dolhańczuk-Śródka, phone +48 77 401 60 46, email: agna@uni.opole.pl
Małgorzata Rajfur, phone +48 77 401 60 42, email: mrajfur@o2.pl

SECRETARIES' OFFICE

phone +48 77 401 60 42
email: mrajfur@o2.pl

Copyright © by
Society of Ecological Chemistry and Engineering, Opole

Ecological Chemistry and Engineering A / Chemia i Inżynieria Ekologiczna A
is partly financed by Ministry of Science and Higher Education, Warszawa

CONTENTS

Katarzyna JAROMIN, Alia JLILATI, Marcin WIDOMSKI and Grzegorz ŁAGÓD – Materials, Exploitation Manners and Roughness Coefficient in Gravitational Sanitation Conduits	853
Grzegorz ŁAGÓD, Henryk SOBCZUK, Zbigniew SUCHORAB and Marcin WIDOMSKI – Flow Parameters Effects on Aerobic Biodegradation of Pollutants in Sewer System	865
Zbigniew SUCHORAB, Agnieszka ŻELAZNA and Henryk SOBCZUK – Water Content Measurement of Building Materials Using Surface TDR Probe	877
Lidia WOLNY and Anna KORZEKWA-WOJTAL – Effect of Polyelectrolyte Dose on the Characteristics of Sewage Sludge in Sedimentation Processes in Small-Size Wastewater Treatment Plants	887
ANNA ŚWIERCZYŃSKA, Jolanta BOHDZIEWICZ and Magdalena AMALIO-KOSEL – Activity of Activated Sludge Microorganisms in the Co-Treatment of the Leachates in the SBR Bioreactor	895
Mariusz DUDZIAK – Effect of the Contact Angel on the Effectiveness of Mycoestrogens Removal from Water Using Nanofiltration Membranes	903
Beata ZAŁĘSKA-CHRÓST, Lech SMOCZYŃSKI and Regina WARDZYŃSKA – Treatment of Wastewater from the Pulp and Paper Industry by Electrocoagulation in a Static System	911
Iwona ZAWIEJA, Paweł WOLSKI and Lidia WOLNY – Recovering of Biogas from Waste Deposited on Landfills	923
Anna ZWOŹDZIAK, Izabela SÓWKA, Maria SKRĘTOWICZ, Anna WOROBIEC, Alicja NYCH, Jerzy ZWOŹDZIAK and Rene VAN GRIEKEN – PM10, PM2.5 and PM1.0 Indoor and Outdoor Concentrations and Chemical Composition in School Environment	933
Agnieszka BARAN, Marek TARNAWSKI and Czesława JASIEWICZ – Assessment of the Content and Solubility of Heavy Metals in Bottom Sediments of the Chancza Reservoir	941
Petr ŠKARPA – Monitoring the Changes in Total Contents of Manganese, Copper and Zinc in Soils from Long-Term Stationary Experiments	951
Krystyna PRZYBULEWSKA, Sylwia MICHAŁOWSKA, Magdalena BŁASZAK and Anna STOLARSKA – Growth of Soil Fungi on Culture Media Contaminated with Selected Herbicides	959
Agata ŚWIĘCIŁO – Effect of Pesticide Preparations and Indoleacetic Acid on Yeast <i>Saccharomyces cerevisiae</i> Cells	967
Alina KOWALCZYK-JUŚKO – Properties of Ash in the Combustion of Selected Energy Crops	973

Krystyna HOFFMANN, Józef HOFFMANN and Filip DONIGIEWICZ – Influence of Concentration of Phosphoric Acid on Obtained Fodder Phosphate Quality	983
Elżbieta HUZAR, Alicja WODNICKA and Małgorzata DZIĘCIOŁ – Analysis of Volatile Compounds in Nail Polish Removers as a Criterion of Health Hazard Determination and Commodity Evaluation	991
VARIA	
Invitation for ECOpole '11 Conference	1001
Zaproszenie na Konferencję ECOpole '11	1003
Guide for Authors on Submission of Manuscripts	1005
Zalecenia dotyczące przygotowania manuskryptów	1007

SPIS TREŚCI

Katarzyna JAROMIN, Alia JLILATI, Marcin WIDOMSKI i Grzegorz ŁAGÓD – Rodzaje materiału i sposoby eksploatacji a współczynniki szorstkości w przewodach kanalizacji grawitacyjnej	853
Grzegorz ŁAGÓD, Henryk SOBCZUK, Zbigniew SUCHORAB i Marcin WIDOMSKI – Wpływ napełnienia kolektora kanalizacji grawitacyjnej na przebieg tlenowych procesów biodegradacji zanieczyszczeń	865
Zbigniew SUCHORAB, Agnieszka ŻELAZNA i Henryk SOBCZUK – Pomiary wilgotności materiałów budowlanych z zastosowaniem powierzchniowej sondy TDR	877
Lidia WOLNY i Anna KORZEKWA-WOJTAL – Wpływ dawki polielektrolitu na charakterystyki osadów ściekowych w procesach sedimentacji w małych oczyszczalniach ścieków	887
Anna ŚWIERCZYŃSKA, Jolanta BOHDZIEWICZ i Magdalena AMALIO-KOSEL – Aktywność mikroorganizmów osadu czynnego w procesie współczyszczania odcieków w bioreaktorze SBR	895
Mariusz DUDZIAK – Wpływ kąta zwilżania membran nanofiltracyjnych na efektywność usuwania mykoestrogenów z wody	903
Beata ZAŁĘSKA-CHRÓST, Lech SMOCZYŃSKI i Regina WARDZYŃSKA – Oczyszczanie ścieków celulozowo-papierniczych metodą elektrokoagulacji w systemie statycznym	911
Iwona ZAWIEJA, Paweł WOLSKI i Lidia WOLNY – Pozyskiwanie biogazu z odpadów deponowanych na składowiskach	923
Anna ZWOŹDZIAK, Izabela SÓWKA, Maria SKRĘTOWICZ, Anna WOROBIEC, Alicja NYCH, Jerzy ZWOŹDZIAK i Rene VAN GRIEKEN – Stężenia oraz skład chemiczny pyłu PM _{1.0} , PM _{2.5} oraz PM ₁₀ w powietrzu wewnętrznym i zewnętrznym szkoły	933
Agnieszka BARAN, Marek TARNAWSKI i Czesława JASIEWICZ – Ocena zawartości i rozpuszczalności metali ciężkich w osadach dennych zbiornika Chańcza	941
Petr ŠKARPA – Monitoring zmian całkowitych zawartości manganu, miedzi i cynku w glebach poddawanych długoterminowym doświadczeniom rolniczym	951
Krystyna PRZYBULEWSKA, Sylwia MICHAŁOWSKA, Magdalena BŁASZAK i Anna STOLARSKA – Wzrost wybranych grzybów glebowych na podłożach zanieczyszczonych wybranymi herbicydami	959
Agata ŚWIĘCIŁO – Oddziaływanie preparatów pestycydowych oraz heteroauksyny na komórki drożdży <i>Saccharomyces cerevisiae</i>	967

Alina KOWALCZYK-JUŚKO – Właściwości popiołu ze spalania wybranych gatunków roślin energetycznych	973
Krystyna HOFFMANN, Józef HOFFMANN i Filip DONIGIEWICZ – Wpływ stężenia zateżonego ekstrakcyjnego kwasu fosforowego na jakość otrzymanych fosforanów paszowych	983
Elżbieta HUZAR, Alicja WODNICKA i Małgorzata DZIĘCIOŁ – Analiza lotnych składników zmywaczy do paznokci jako kryterium oceny zagrożenia zdrowia i oceny towaroznawczej	991
VARIA	
Invitation for ECOpole '11 Conference	1001
Zaproszenie na Konferencję ECOpole '11	1003
Guide for Authors on Submission of Manuscripts	1005
Zalecenia dotyczące przygotowania manuskryptów	1007

Katarzyna JAROMIN¹, Alia JLILATI¹,
Marcin WIDOMSKI¹ and Grzegorz ŁAGÓD¹

MATERIALS, EXPLOATATION MANNERS AND ROUGHNESS COEFFICIENT IN GRAVITATIONAL SANITATION CONDUITS

RODZAJE MATERIAŁU I SPOSOBY EKSPLOATACJI A WSPÓŁCZYNNIKI SZORSTKOŚCI W PRZEWODACH KANALIZACJI GRAWITACYJNEJ

Abstract: The interceptor of urban wastewater should be treated as a collector and transporter of sewage. The roughness coefficient n is one of the basic parameters influencing the hydraulic conditions of open channels (gravitational flow). The value of n coefficient depends on channel material, carefulness of conjunctions execution and the amount of settled sediments. During the conducted experiments real roughness coefficients of four chosen sanitation conduits in Chelm, Poland were obtained. The choice was made because the different: age of pipes, materials, diameters, inclinations and mean sewage flow velocities. The calculations of n coefficient were based on the Manning formula. The gained results proved the hypothesis of real roughness coefficient increase during the long-lasting exploitation of sanitation channels. The analysis of gained results for selected sanitation pipes in Chelm showed the maximal 43.1 % gain of n coefficient compared with values presented in projecting guidelines. The presented research may be useful during creation and calibration of Chelm sanitation network numerical model. Application of real values of roughness coefficient during model calibration allows to obtain results of calculations more precisely describing the simulated phenomenon.

Keywords: roughness coefficient, Manning formula, calibration of sewer system hydraulic model

During the analysis of sanitation system operation one may note many factors and parameters causing perturbations and deteriorating wastewater and sediments transport. One of the most important factors influencing hydraulic conditions of sewage flow is roughness coefficient n [1]. However, the geometric characteristics of the conduit, usually presented in technical documentation, as well as the real value of sewage flow velocity and height of deposited sediments are necessary to obtain the n factor. The knowledge of factors describing the pipe inner side roughness and coarseness is very

¹ Faculty of Environmental Engineering, Lublin University of Technology, ul. Nadbystrzycka 40B, 20-618 Lublin, Poland, phone: 81 538 43 22, email: G.Lagod@wis.pol.lublin.pl

important because of several reasons. The pipes' inner side roughness is a very important hydraulic factor predicating their capacity and exploitation parameters.

In case of pipes positioned with low inclinations, their roughness is usually causing the increased sediments deposition. In order to prevent this effect, the sewage flow velocity should amount to 0.8 m s^{-1} . This value ensures the self-purification of pipes, so the designing of conduits according to prescribed minimal inclinations, obtained from the contrary of pipe diameter is often used [2, 3]. The criteria of pipes material choice should be analyzed separately for the each studied case, taking into account, besides the economical reasons, also the local conditions, ground and groundwater parameters, type of sanitation systems and chemical composition of wastewater.

The reliability and security of sanitation system, even designed and constructed according to the best, actual engineering knowledge can not be assured. In this case, the ultimate requisites to obtain this purpose are the proper exploitation of the sewage system by the wastewater delivers and the proper maintenance conducted by the exploitation companies.

The avoidance or limitation of sanitation systems failures and their consequences is possible due to the elimination of their formation reasons. Therefore, the regular diagnostics of sanitation system condition and planned pipes regeneration, precluding the occurrence of particularly hazardous threats is necessary. The planning of exploitation activities in operated conduits may be considerably facilitated by the calibration of hydraulic computer network models based on the real values of roughness coefficients.

The aim of this paper is to determine the real values of roughness coefficients n describing sanitation pipes after the long lasting time of exploitation. Four channels of different exploitation time were considered. Our studies were based on the following measurements: sewage flow velocity in steady conditions, height of deposited sediments bed, sewage level and geometrical parameters of the studied pipes.

Materials and methods

This research was based on measurement of sewage flow velocity in the chosen sanitation Pipes in Chelm, Poland along with the geometrical characteristic of pipes, active wastewater stream height and amount of deposited sediments [4, 5]. The sanitation system in Chelm is consisting of circular pipes of diameters from 200 mm to 1400 mm. The 200 mm PVC and ceramics pipes prevail in the studied network. The sewages are transported mainly gravitationally. Table 1 presents the materials used in sanitation system of Chelm city as well as their total length. The percentage share of particular material length in the length of the whole network is also presented at Table 1 [4].

Pipes of diameters up to 250 mm have the highest share among ceramics conduits – 57 %, pipes of diameters 250–600 mm represent 43 %. The ceramics pipes of diameter higher than 600 mm are not present in the sanitation system of Chelm city. Among the PVC sanitation conduits the dominant part are pipes of diameter up to 250 mm (75 %). The group of concrete pipes covers nearly all available diameters, whereof diameters up

to 250 mm are 9 % of the whole length of concrete pipes and diameters from 250 to 600 mm represent the share of 29 %. The most frequently noted concrete pipes have the diameter larger than 600 mm – 62 % share.

Table 1

Conduits of different materials in studied sewer system – Chelm,
Poland (situation in 2006)

Material	Length [m]	[%]
Ceramics	70 000	40
Concrete	52 500	30
PVC	42 000	24
Cast iron	7 000	4
Cement	3 500	2
Σ	175 000	100

The measurements of n roughness coefficient real values for the four selected sanitation pipes were conducted. The real value of n coefficient represents the actual flow conditions in the pipe – considering the wetted perimeter of pipe material and sediment bed. The choice of selected pipes was influenced by the time of their exploitation, material, diameters as well as pipes inclination. Thus, the following pipes were selected to studies: 800 mm at Pilarski St., constructed in 1970s, 600 mm at 3rd May St., constructed in 1980s, and 400 mm at Karłowicz St., exploited since 2007 [4].

The conducted linear measurements covered the height of sewage flow level and the height of deposited sediments bed. The sewage temperature was also measured. The Pitot-Darcy probe was used to obtain the wastewater velocity flow. The flow velocity was calculated according to equation (1) [6].

$$v = 4.47 \sqrt{h} \quad (1)$$

where: v – sewage flow velocity [m s^{-1}],
4.47 – correcting coefficient [-],
 h – height difference in Pitot-Darcy probe [m].

In order to confirm the obtained results, the sewage velocity flow was additionally measured by the floating object method. The flow direction and pipe longitudinal axis were parallel in sanitation conduit in which the floating object method was used.

The segmental wastewater flow velocity was calculated by follows [6]:

$$v = \frac{L}{t} \quad (2)$$

where: L – length of floating object movement [m],
 t – floating object movement time [s].

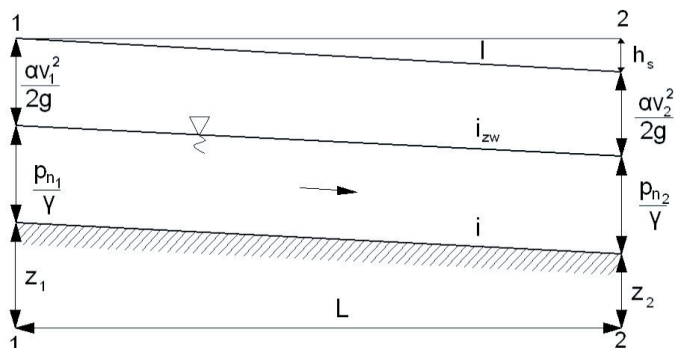

Fig. 1. Graphical scheme to Bernoulli equation (4) [7]

The constant flow is a steady flow, therefore kinetic energy and liquid flow velocity are constant. All this mean that the channel bottom inclination i is equal to the inclination of the piezometric pressure line i_{zw} and the inclination of the energy line – hydraulic inclination I [7].

$$i = i_{zw} = I \quad (3)$$

Bernoulli equation for 1-1 and 2-2 cross sections presented at Figure 1 may be written as follows:

$$z_1 + \frac{p_1}{\gamma} + \frac{\alpha v_1^2}{2g} = z_2 + \frac{p_2}{\gamma} + \frac{\alpha v_2^2}{2g} + \lambda \frac{L}{4R_h} \frac{v^2}{2g} \quad (4)$$

where: R_h – hydraulic radius [m],

z – elevation [m],

p – pressure at the point [N m^{-2}],

α – Coriolis coefficient [-],

γ – specific weight [N m^{-3}],

λ – the dimensionless coefficient of Darcy friction factor [-] [8].

Taking above into account, we may use the following formula describing the sewage flow velocity:

$$v = \sqrt{\frac{8g}{\lambda}} \sqrt{R_h I} \quad (5)$$

The first part of equation (5) may be described as C , known as Chezy factor [7, 9, 10]:

$$C = \sqrt{\frac{8g}{\lambda}} \quad (6)$$

The relative coarseness value depends on the value of the absolute coarseness k connected to the mean height, shape and distribution of inner pipe surface inequality [7].

The formula describing the mean value of flow velocity may be written as follows:

$$v = C\sqrt{R_h I} \quad (7)$$

Beside the presented formula (6), many other empirical formulas may be used to obtain the C factor. The comparison of Chezy formula and the formula of steady flow velocity in open channels presented by Manning is frequently used:

$$v = \frac{1}{n} R_h^{2/3} I^{1/2} \quad (8)$$

Thus, the description of C factor in dependence of roughness coefficient n [$\text{s m}^{-1/3}$] and hydraulic radius R_h is possible [8]:

$$C = \frac{1}{n} R_h^{1/6} \quad (9)$$

In order to calculate the roughness coefficient, Manning formula (8) may be transformed to:

$$n = \frac{1}{v} R_h^{2/3} i^{1/2} \quad (10)$$

where: v – mean value of flow velocity measured by the floating object method and Pitot-Darcy probe [m s^{-1}].

The hydraulic radius was calculated with use of the following formula (11):

$$R_h = \frac{A_c}{P_w} \quad (11)$$

where: A_c – conduit cross sectional flow area [m^2],
 P_w – wetted perimeter [m].

Results

The results of sewage flow velocity measurements by the Pitot-Darcy probe are presented in Table 2. The other data, necessary to floating object method, as pipe inclination and conduit segment length were obtained from the representatives of Chelm city sanitation network exploitation company [4].

Table 2

Measured velocity of sewage flow by Pitot-Darcy probe
in chosen sanitation conduit in Chelm, Poland

No.	Sewage level h [m]	Flow velocity v [m s ⁻¹]	Mean flow velocity v_m [m s ⁻¹]
Pilarski St., Ø 800; $i = 2.0$ ‰, concrete			
1	0.0140	0.529	0.532
2	0.0145	0.538	
3	0.0140	0.529	
3 rd May St., Ø 600; $i = 2.5$ ‰, concrete			
1	0.0050	0.316	0.311
2	0.0045	0.300	
3	0.0050	0.316	
3 rd May St., Ø 600; $i = 2.5$ ‰, concrete			
1	0.0060	0.346	0.341
2	0.0055	0.332	
3	0.0060	0.346	
Karłowicz St., Ø 400; $i = 5.0$ ‰, PVC			
1	0.0025	0.224	0.238
2	0.0030	0.245	
3	0.0030	0.245	

The results of wastewater flow velocity obtained by the floating object method are presented in Table 3.

Table 3

Measured velocity of sewage flow by floating object method
in chosen sanitation conduit in Chelm, Poland

No.	Flow duration			Pipe length [m]	Sewage level [m]	Sediments height [m]	Sewage temperature [°C]	Velocity [m s ⁻¹]	Mean velocity [m s ⁻¹]
	min	sec	cs						
Pilarski St., Ø 800; $i = 2.0$ ‰, concrete									
1	0	26	15	15.1	0.26	0.08	16	0.575	0.528
2	0	29	1					0.520	
3	0	30	3					0.502	
4	0	28	43					0.526	
5	0	29	12					0.517	
3 rd May St., Ø 600; $i = 2.5$ ‰, concrete									
1	7	12	30	142.22	0.19	0.09	16	0.329	0.317
2	7	32	20					0.314	
3	7	20	3					0.323	
4	7	24	50					0.320	
5	7	52	41					0.301	

Table 3 contd.

No.	Flow duration			Pipe length [m]	Sewage level [m]	Sediments height [m]	Sewage temperature [°C]	Velocity [m s ⁻¹]	Mean velocity [m s ⁻¹]
	min	sec	cs						
3 rd May St., Ø 600; <i>i</i> = 2.5 ‰, concrete									
1	3	41	15	75	0.195	0.09	16	0.339	0.336
2	3	50	3					0.326	
3	3	38	42					0.343	
4	3	33	17					0.352	
5	3	55	5					0.319	
Karłowicz St., Ø 400; <i>i</i> = 5.0 ‰, PVC									
1	3	28	4	46.22	0.04	0.015	16.5	0.222	0.226
2	3	18	15					0.233	
3	3	25	3					0.225	
4	3	21	40					0.229	
5	3	30	7					0.220	

The measurements which results are presented in Table 2 and 3 were conducted for every studied pipe at the same time – about 10 and 12 a.m., when the sewage level in pipes was relatively constant. In this case, the assumption of constant sewage flow is close to reality – the sewage stream of constant flow rate Q , constant crosssection area A_c , fixed height of sewage level h on the whole length of conduit are required to obtain the parallel position of water table and pipe bottom.

The obtained during research real coefficient of roughness for studied sanitation pipes placed in Chelm city is presented in Table 4:

Table 4

Measurements results for selected sanitation pipes in Chelm, Poland

Street	Material	Diameter Ø [m]	Inclination <i>i</i> [%]	Hydraulic radius R_h [m]	Mean velocity v [m s ⁻¹]	Roughness coefficient n [s m ^{-1/3}]
Pilarski	Concrete	0.800	2.0	0.064	0.530	0.0141
3rd May	Concrete	0.600	2.5	0.040	0.314	0.0186
3rd May	Concrete	0.600	2.5	0.036	0.339	0.0160
Karłowicz	PVC	0.400	5.0	0.010	0.232	0.0142

Discussion

Figure 2 presents the results of flow velocity measurements by floating object method as well as by the Pitot-Darcy probe. The comparison of obtained velocity values to the self-purification velocity was also presented.

The results of conducted research showed that the self-purification velocity of flow was not secured in the examined conduits. In the studied case the process of sediments

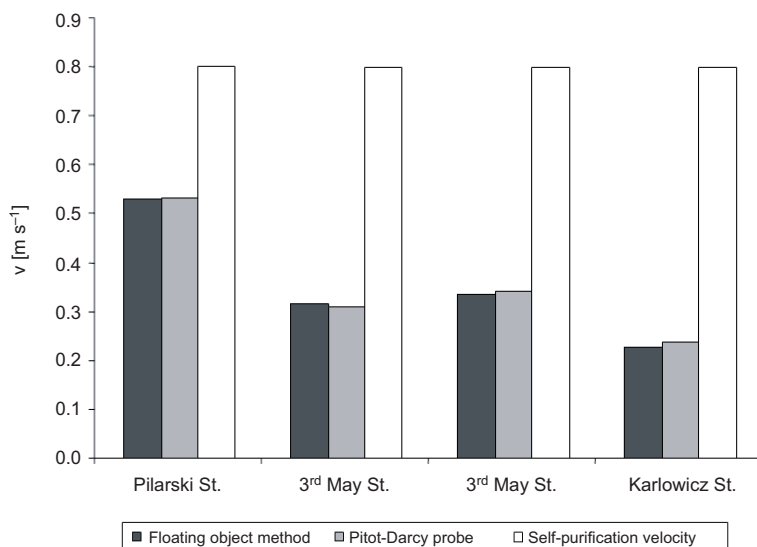

Fig. 2. Graphical illustration of sewage velocity measurements results compared to self-purification velocity

deposition will occur, resulting in creation of sediments bed, decrease of active area of flow, increase of flow resistances and reduction of channel hydraulic capacity. The field research covering flow velocity and sediments bed height showed that in case of insufficient flow velocity, sediments deposition was noted in all studied pipes. The thickness of sediments beds starting from 1.5 cm in channel used since 2007 to 8–9 cm in pipes used for 20–30 years were observed. This status certainly adversely influence the hydraulic conditions of studied parts of the sanitation system by, for instance, increase of the real roughness coefficient of the conduit.

The other conduit parameters such as inclination and diameter are chosen to secure the self-purification velocity of wastewater flow.

The value of n equal to $0.013 \text{ s m}^{-1/3}$ is usually used for concrete pipes in hydraulical calculations during the sanitation designing. Table 5 present the record of the most frequently cited values of n for several materials.

Our research proved the hypothesis of roughness coefficient increase during the long term exploitation of sanitation system. In some cases even the 43.1 % gain of n coefficient compared with values presented in designing guidelines was noted.

The increase of roughness coefficient n results from the decrease of flow velocity calculated after Manning formula (8). Thus, the noted value of flow velocity is lower than assumed during designing calculations. If its value is lower than the velocity of pipe self-purification the process of sediments deposition will occur. The velocity of flow is dependent to pipe roughness but reduction of velocity causes the increase of real surface roughness through the decline of deposited sediments. Hence, the real roughness coefficient n studied in this paper becomes one of the major factors influencing the hydraulic conditions of flow in the gravitational sanitation systems.

Table 5

Coefficient n by Manning, M coefficient by Manning-Strickler [11–13]

No	Type of surface, material	$n = 1/M$ [s m ^{-1/3}]	M [m ^{1/3} s ⁻¹]
1	Smooth glaze surfaces	0.009	111
2	Planed wood	0.010	100
3	Smooth concrete	0.0118	85
4	Normal concrete	0.0133	75
5	Rough concrete	0.0147	68
6	Plastic	0.0125	80
7	Smooth stone	0.0125	80
8	Ceramics	0.0143	70
9	Iron	0.0143	70
10	Bricks	0.0167	60
11	Broken stone wall, channel in bad condition	0.020	50
12	Channel in extremely bad condition, silted	0.030	33

The choice of the most suitable solution in aspect of hydraulic conditions is also possible due to numerical calculations. The computer modeling allows variable, optional design of considered layout of sanitation and its short- and long-term efficiency in different conditions. But the quality and accuracy of the computer modeling in reflecting the real conditions, despite its proper mathematical description, are directly connected to the introduced input data [13, 14]. When the geometrical parameters and pipe material roughness for the new, unused material are input the results of flow parameters calculation may differ from the real values. The calibration of computer model becomes necessary. The real shape of the sewage stream cross-section, its wetted perimeter and hydraulic radius as well as resultant roughness coefficient n describing additionally resistance after sediments deposition and type of sediments have to be reflected.

Summary and conclusions

The roughness coefficient value depends on pipe material as well as type and quality of pipe segments bonds and sediments deposited along the conduit.

Considering the roughness of sanitation pipe walls we have to distinguish the initial and final roughness – after the specified time of exploitation.

At the analysis of measurement results and comparison to the values used in the designing practice we may state that the values of the actual real roughness coefficient n obtained during measurements are higher than values used in the process of sanitation system designing. The roughness coefficient value 0.014–0.018 s m^{-1/3} for the concrete pipes were observed, as 0.013 s m^{-1/3} is the basic value in designing.

The increase of n coefficient is connected to the low values of sewage flow, which does not provide the correct flushing of the sanitation pipes. In result, the sediments

deposition occurs and the deposited sediments are adversely influencing hydraulical conditions of flow.

The on-line measurements are recommended in order to obtain more precise data concerning sewage flow and roughness coefficient in sanitation system in Chelm, Poland.

The presented research may be useful during creation and calibration of Chelm sanitation network numerical model. Application of real values of real roughness coefficient during model calibration allows to obtain results of calculations more precisely describing the simulated phenomenon.

Acknowledgements

We are grateful to representatives of Chelm city sanitation network exploitation company (MPGK) – Marian Tarasewicz, Tomasz Borkowski, Piotr Olida and Krzysztof Szyszowski for data connected with geometrical description of conduits and their help in field researches.

References

- [1] Dąbrowski W.: Oddziaływanie sieci kanalizacyjnych na środowisko. Wyd. Polit. Krakow., Kraków 2004.
- [2] Błaszczak W., Roman M. and Stamatello H.: Kanalizacja, t. 1. Arkady, Warszawa 1974.
- [3] Heidrich Z.: Kanalizacja. WSiP, Warszawa 1999.
- [4] Jaromin K., Borkowski T., Łagód G. and Widomski M.: *Analiza wpływu rodzaju materiału oraz czasu i sposobu eksploatacji kolektorów kanalizacji grawitacyjnej na prędkość przepływu ścieków*. Proc. ECOpole, 2009, 3(1), 139–145.
- [5] Jaromin K., Jilati A., Borkowski T., Widomski M. and Łagód G.: *Rodzaje materiału i sposoby eksploatacji a współczynniki szorstkości w przewodach kanalizacji grawitacyjnej*. Proc. of ECOpole, 2008, 2(2), 439–444.
- [6] Dębski K.: Hydrologia. Arkady, Warszawa 1970.
- [7] Mitosek M.: Mechanika płynów w inżynierii środowiska. Ofic. Wyd. Polit. Warszaw., Warszawa 1997.
- [8] Jeżowiecka-Kabsch K. and Szewczyk H.: Mechanika płynów. Ofic. Wyd. Polit. Wrocław., Wrocław 2001.
- [9] Orzechowski Z., Prywer J. and Zarzycki R.: Mechanika płynów w inżynierii środowiska. WNT, Warszawa 2001.
- [10] Sawicki J.: Przepływy ze swobodną powierzchnią. Wyd. Nauk. PWN, Warszawa 1998.
- [11] ATV-DVWK-A110P: Wytyczne do hydraulicznego wymiarowania i sprawdzania przepustowości kanałów i przewodów ściekowych. Deutsche Vereinigung für Wasserwirtschaft, Abwasser und Abfälle. V., GFA, Wyd. Seidel Przywecki, Warszawa 1988.
- [12] Łagód G.: Modelowanie procesów biodegradacji ścieków w kolektorach kanalizacji grawitacyjnej. Praca doktorska, Lublin 2007.
- [13] MOUSE PIPE FLOW – Reference Manual. DHI Water & Environment, Horsholm 2003.
- [14] Jilati A., Widomski M and Łagód G.: *Influence of conduit geometrical characteristics on sewage flow parameters*. Proc. ECOpole, 2008, 2(2), 329–335.

RODZAJE MATERIAŁU I SPOSOBY EKSPLOATACJI A WSPÓLCZYNNIKI SZORSTKOŚCI W PRZEWODACH KANALIZACJI GRAWITACYJNEJ

Wydział Inżynierii Środowiska, Politechnika Lubelska

Abstrakt: Współczynnik szorstkości n jest jednym z podstawowych parametrów wpływających na warunki hydrauliczne przepływów ze swobodnym zwierciadłem. Wartość współczynnika szorstkości zależy od

materiału, z którego zbudowany jest kanał, od rodzaju, staranności wykonania połączeń oraz od zgromadzonych na dnie i obrastających ściany kanału osadów. Przeprowadzono badania współczynnika szorstkości n dla 4 wybranych przewodów kanalizacji sanitarnej w Chełmie. Wyboru dokonano ze względu na różny czas ich eksploatacji, rodzaj materiału, średnice i spadki kanału oraz prędkości przepływu ścieków. Obliczenia współczynnika szorstkości n przeprowadzono, wykorzystując przekształcony wzór Manninga. Uzyskane wyniki potwierdziły hipotezę, zakładającą wzrost wartości współczynnika n w czasie eksploatacji sieci. Analizując otrzymane wyniki i porównując je z założeniami projektowymi, stwierdzono, iż wyznaczony współczynnik szorstkości dla wybranych przewodów sieci kanalizacyjnej w Chełmie jest większy nawet o 43,1 % od wartości podanych w wytycznych do projektowania. Przeprowadzone badania mogą być pomocne przy budowie i kalibracji modelu hydraulicznego sieci kanalizacyjnej miasta Chełm. Zastosowanie rzeczywistych wartości współczynnika szorstkości w procesie kalibracji modelu numerycznego umożliwi uzyskanie wyników obliczeń symulacyjnych w lepszym stopniu odzwierciedlających procesy zachodzące w opisywanych obiektach.

Słowa kluczowe: współczynnik szorstkości, wzór Manninga, kalibracja modelu hydraulicznego sieci kanalizacyjnej

Grzegorz ŁAGÓD¹, Henryk SOBCZUK¹,
Zbigniew SUCHORAB¹ and Marcin WIDOMSKI¹

FLOW PARAMETERS EFFECTS ON AEROBIC BIODEGRADATION OF POLLUTANTS IN SEWER SYSTEM

WPLYW NAPEŁNIENIA KOLEKTORA KANALIZACJI GRAWITACYJNEJ NA PRZEBIEG TLENOWYCH PROCESÓW BIODEGRADACJI ZANIECZYSZCZEŃ

Abstract: The interceptor of urban wastewater should be treated as a collector and transporter of sewage and also as a bioreactor, with a continuous inflow, growth and washing out of biomass. Specific sewage biodegradation processes were described by suitable mathematical models of biomass growth and decay. For given system it is possible to compose the matrix of integrated process of organic substance transformation in the gravitational sewer system. Numerical model based on described processes contains stoichiometric and kinetic parameters of sewage biodegradation appropriate to living microfauna of saprobionts as a biological processing factor in sewer pipe and a precursor of activated sewage sludge in wastewater treatment plant. Complete numerical implementation of a model includes also a module of sewer channel hydrodynamic calculation based on Saint-Venant equation. As a last part of necessary modules advection-dispersion equation is used. This kind of model, makes it possible to demonstrate the changes of pollutants load change to the wastewater treatment plant through interceptor of a sewage system. It can be also used to predict influence of combined sewer overflows on receiving waters. This paper, based on the previous achievements is a case study to create a model describing the process of self-purification of urban sewage running in gravitational sewer in the presence of saprobiontic microfauna.

Keywords: sewer, physico-chemical sewage parameters, microbial transformation modelling, biodegradation of pollutants in sewer system, Saint-Venant equation, advection-dispersion equation

Heretofore, the researches' attention, concerning the problem of sanitation and wastewater treatment, was first of all focused on pollutants transformation processes inside *wastewater treatment plant* (WWTP) and its hydraulic transport through the sanitation system. Sewer system, in respect of its range, is the most expensive part of a municipal system of sewage removal. Despite the fact that sanitation system is often perceived as a simple manner of hydraulic sewage transport, many various complex

¹ Faculty of Environmental Engineering, Lublin University of Technology, ul. Nadbystrzycka 40B, 20-618 Lublin, Poland, phone: +48 81 538 43 22, email: G.Lagod@wis.pol.lublin.pl

processes occur inside it. These are the physical, chemical and biochemical processes, which greatly change the properties of sewage entering WWTPs [1–10]. In respect of their mentioned range the sanitation systems have a large capacity which, on account of low hydraulic loads during the major part of day, may be used in preliminary wastewater treatment [3, 6, 8, 9]. But the precise determination of biodegradation processes rate in particular sewage systems is still problematic. However, the most important biochemical transformations occurring inside sanitation are nowadays known [4–10], though we still lack the quantitative and qualitative data concerning relations and affiliations of all occurring processes and their influence on the technological processes of WWTPs.

Influence of sewer processes on WWTP work regime

The studies cited above show that considerable development of knowledge concerning sewage transport and technology of biological wastewater treatment and taking place during last two decades introduced the fundamental changes in understanding and perception of processes connected to sanitation systems and operation of WWTPs based on biological treatment. It was noted that the biological processes, traditionally connected to the particular parts of WWTPs occur also at different locations and even outside the treatment plants, leading to appearance of different but sometimes noticeable effects which were unintentional by the designer.

A lot of complex processes occur between the point of sewage introduction to the system and WWTP, in effect of which the treatment plant may be reached by sewage of different parameters than assumed at the stage of WWTP technology design. Even in the nineties of XXth century the concentrations changes developed during sewage flow through sanitation system were connected to dilution by infiltration water. But in this case the pollutants load should not have been changed. The following studies [1, 3–10] reported its changes, so the designing assumptions of WWTP based on *population equivalent* (PE) for the extensive sanitation network cannot be fulfilled. The introduction of applicable corrective coefficients considering these transformations seems to be advisable. Such coefficients and proper designing guidelines allowing to roughly estimate the effects of pollutants biodegradation processes may be elaborated basing on field tests and model studies.

The proper elements should be functionally related together during the development of complex model of processes occurring inside the sanitation conduit. These elements are: local model of transformations caused by an active heterotrophic biomass in aerobic conditions, hydrodynamic model of sewage flow and advection–dispersion model of pollutants transport. The model completed in such a manner should be then supplied in the input parameters, boundary and initial conditions.

Assumption of local model of sewage biodegradation inside sanitation pipes

The gravitational sanitation systems are in many aspects identical to WWTPs with biological treatment in terms of the dominant biochemical processes [6, 7, 9, 10]. The

manner of modelling of sewage transformations caused by microorganisms settled sanitation, thus may be based on the Henze's [11] description of phenomena occurring inside wastewater treatment objects, where sewage are being treated by an active sludge. Some elements may also be based on river flow and self-purification models, however some important differences concerning the system definition and occurring processes as well as different validity of its several elements should be noted [6, 7, 9, 11–15].

The direct application of *Activated Sludge Models* (ASM) group to description of sanitation processes is not advisable because:

- different hydraulic conditions,
- biochemical transformations occurring simultaneously in suspended biomass and biofilm,
- diversity of substances limiting the biomass growth,
- lack of preliminary sedimentation process,
- direct influence of rainfall event on sanitation system,
- oxygen concentration in sewage dependent to reaeration through the free surface and inflow in diluted form included in wastewater.

Taking into account models used to describe water movement and biodegradation in watercourses one should notice the following differences:

- concentration of suspended biomass is clearly higher than in natural watercourses,
- microorganisms development is not limited by nutrients according to the high COD concentration in sewage,
- nitrification rate in sanitation is slower because the nitrifying biomass coating by sooner developing heterotrophs,
- clear daily hydraulic and pollutants load diversity in sewerage,
- no primal production in most sewage systems resulted from the lack of sunlight,
- well specified sanitation pipes geometry.

In order to describe the biodegradation processes of sewage inside sanitation gravitational conduit one has to entertain the microbiological transformations of organic substance in aerobic conditions. The aerobic conditions and suspended biomass as well as biofilm incidence are the assumption taken for the presented model. Providing for the most important properties of the modelled system and interactions among its basic parts is thus possible. The mentioned interactions cover: biomass development, biodegradable substances hydrolysis and consumption of dissolved oxygen. The sewage components are considered in aspect of biomass, substrates and acceptors for the electrons incoming from liquid phase and solids suspended in it. The biomass developed beneath sewage free surface is being taken into account. Heterotrophic biomass concentration in the liquid phase of sewage is usually low in comparison with the concentration of biomass in an active sludge and the amount of nutrients available for biomass inside sanitation pipes is usually relatively high. There is an easily biologically degradable substrate available in a raw sewage, accessible in such quantities that in most cases it does not limit the development of heterotrophic organisms biomass [6, 7, 9, 10, 12, 14–16].

The *in situ* research on full scale sanitation systems showed that biofilm is a very important factor in the process of sewage biodegradation [6, 7, 9–12]. In some cases the

participation of biofilm in sewage biodegradation may be higher than the suspended biomass. It is possible during the phases of flow with low shear stress and low conduit filling.

The additional element also taken into account in the presented model is temperature, which is a very important factor because it influences the enzymatic activity of microorganisms and oxygen solubility in wastewater.

Sewage reaeration in gravitational sanitation

The degree of sewage aeration matters considerably in case of aerobic processes of pollutants biodegradation conducted by heterotrophic biomass inside the sanitation system. This degree depends on many factors, among which, the most important are: oxygen concentration in air over sewage free surface, area of contact between air and sewage and hydraulic properties of flow [17–19].

The sanitation networks designing guidelines [17] show that relative depth of filling should not exceed 0.8 ratio of the total pipe inner diameter to prevent sewage from rotting. The incomplete filling of conduit asserts the appearance of air zone in the upper part of canal cross-section which makes the reaeration of sewage possible.

As a results of theoretical studies supported by experimental data, the formulas describing sewage reaeration inside gravitational sanitation conduits were developed.

The basic equation is presented as [6, 7, 9, 10]:

$$\rho_{\text{rea}} = aK_L a(20) (\beta S_{\text{OS}} - S_{\text{O}}) a_r^{(T-20)},$$

where: ρ_{rea} – oxygen transfer rate [$\text{g m}^{-3}\text{d}^{-1}$],

a – coefficient providing for detergents impact, usually about 0.95 [-],

a_r – coefficient providing for temperature impact on reaeration, usually about 1.024 [-],

β – coefficient of different oxygen solubility in sewage and clear water, usually between 0.8–0.95 [-],

S_{O} – dissolved oxygen concentration [g m^{-3}],

S_{OS} – saturation concentration of dissolved oxygen in sewage, in equilibrium to atmosphere [g m^{-3}].

The empirical formula developed to term the general oxygen transfer coefficient $K_L a(20)$ in gravitational sanitation may be written as follows [6, 7, 9, 10]:

$$K_L a(20) = 0.86 (1 + 0.2\text{Fr}^2) (\text{sU})^{3/8} \text{H}^{-1},$$

where: Fr – Froude number [-],

U – mean velocity [m s^{-1}],

s – conduit bottom inclination [m m^{-1}],

H – mean hydraulic depth = A/B [m].

Processes connected to heterotrophic biomass activity

The researches conducted on real working objects showed that biofilm is a very important factor in discussed process [6, 7, 10, 12]. In some cases its share in sewage biodegradation may be higher than the part of suspended biomass, eg during the flow of low shear stress and low filling of the sewage conduit. The additional factor considered in presented model is temperature which is very important because its influence on enzymatic activity of microorganisms.

In order to describe the biofilm heterotrophic biomass development rate in aerobic conditions, the deterministic model based on information contained in [4, 7, 9] may be used:

$$\rho_{Bf} = k_{1/2} S_O^{1/2} \frac{Y_{Hf}}{1 - Y_{Hf}} \frac{S_S}{K_{Sf} + S_S} \frac{A_{Bf}}{V} a_f^{(T-20)},$$

where: $k_{1/2}$ – half-order rate constant [g O₂^{1/2} m^{-1/2} d⁻¹],
 S_O – dissolved oxygen concentration [g O₂ m⁻³],
 Y_{Hf} – yield constant for X_{Bf} [g COD g COD⁻¹],
 K_{Sf} – saturation constant for readily biodegradable substrate in biofilm [g COD m⁻³],

A_{Bf}/V – wetted biofilm surface area divided by the water volume = R_h^{-1} [m⁻¹].

The development of heterotrophic biomass suspended in sewage is limited by the quantity of available biodegradable diluted fraction and dissolved oxygen in sewage. Basing on ASM No. 1 model the rate of development ρ_z may be written as follows:

$$\rho_z = \mu_H \frac{S_S}{K_S + S_S} \frac{S_O}{K_O + S_O} X_{Bz} a^{(T-20)},$$

where: μ_H – maximum specific growth rate of heterotrophic biomass [d⁻¹],
 S_S – readily biodegradable substrate [g COD m⁻³],
 K_S – saturation constant for readily biodegradable substrate S_S [g COD m⁻³],
 K_O – saturation constant for dissolved oxygen [g O₂ m⁻³],
 X_{Bz} – heterotrophic active biomass in suspension [g COD m⁻³],
 a – temperature coefficient for the water phase process [-],
 T – temperature [°C].

The required maintenance energy covers the energy necessary to conduct life processes of biomass in wastewater. It shows that consumption of nutrients and oxygen do not cause the increase of microorganism mass.

The described energy is collected from dissolved biodegradable fraction of COD and in case of its absence by endogenic respiration. The presented relations may be written as follows [7, 9]:

$$\rho_m = q_m \frac{S_O}{K_O + S_O} X_{Bz} a^{(T-20)},$$

where: q_m – maintenance energy requirement rate constant [d⁻¹].

Considering the hydrolysis of n suspension fraction (individual hydrolysis at different rate) in sewage under the influence of suspended biomass and biofilm enzymes at given temperature, the following equation for rate of this process r may be written [7, 9]:

$$\rho_{h,n} = k_{hn} \frac{X_{Sn} / X_{Bz}}{K_{Xn} + X_{Sn} / X_{Bz}} \frac{S_O}{K_O + S_O} \left(X_{Bz} + \varepsilon X_{Bf} \frac{A_{Bf}}{V} \right) a^{(T-20)},$$

where: k_{hn} – hydrolysis rate constant, fraction n [d^{-1}],
 K_{Xn} – saturation constant for hydrolysis, fraction n [$g \text{ COD } g \text{ COD}^{-1}$],
 X_{Sn} – hydrolysable substrate, fraction n [$g \text{ COD } m^{-3}$],
 X_{Bf} – heterotrophic active biomass in biofilm [$g \text{ COD } m^{-2}$],
 ε – efficiency constant for the biofilm biomass [-].

Integrated process matrix

The presented equation of sewage reaeration rate, along with description of the other processes resulting in pollutants biodegradation with corresponding stoichiometric coefficients may be written as a processes matrix [9, 15, 20]. This matrix organizes and presents in clear manner the description of biochemical transformations occurring in the unit volume of gravitational sanitation conduit. This integrated process matrix contains the set of first order differential equations written in form of matrices and vectors.

The specific sewage biodegradation processes were described by suitable mathematical models of biomass growth and decay. For presented system it is possible to compose the matrix of integrated process of organic substance transformation in the gravitational sewer system. Numerical model based on the described processes contains stoichiometric and kinetic parameters of sewage biodegradation appropriate to living microfauna of saprobionts as a biological processing factor in sewer pipe and a precursor of activated sewage sludge in WWTP.

Table 1

Integrated process matrix – model concept, process kinetics and stoichiometry for sewage biodegradation caused by biofilm and suspended biomass [6, 7, 9, 10]

	Process	Component					Process rate ρ_j
		1 (S_S)	2 (X_{S1})	3 (X_{S2})	4 (X_B)	5 ($-S_O$)	
1	Reaeration					-1	ρ_{rea}
2	Biofilm biomass growth	$-1/Y_{Hf}$			1	$(1-Y_{Hf})/Y_{Hf}$	ρ_{Bf}
3	Suspended biomass growth	$-1/Y_{Hz}$			1	$(1-Y_{Hz})/Y_{Hz}$	ρ_z
4	Maintenance energy requirement	-1			-1*	1	ρ_m
5	Hydrolysis, $n = 1$	1	-1				$\rho_{h \ n = 1}$
6	Hydrolysis, $n = 2$	1		-1			$\rho_{h \ n = 2}$

* If S_S is not sufficiently available to support biomass needs maintenance energy requirement is taken from X_B .

Sewage flow and biodegradation in gravitational sanitation conduit

Simulations of sewage biodegradation processes require the suitable input data considering hydraulic conditions of sewage transport in sanitation conduit. The calculations are conducted for already existing or designing pipe, thus its shape, diameter, inclination and material are already known. It is possible, basing on the mentioned data, to assign sort of movement and calculate sewage flow velocity for assumed or measured sewage filling in case of different degree of channel deterioration and to relate obtained values to the flow rate. The introduced data allow to obtain information about the value of shear stress, dimensionless quantity (eg Froude number) describing the type of movement and area of contact between flowing sewage and pipe material. These variables, along with the others, which may be determined for the object presented at schematic Fig. 1, allow to run the simulation based on constructed by the Authors calculating module.

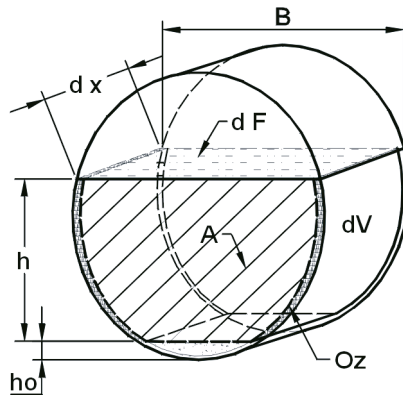

Fig. 1. Parameters connected to geometry and hydrodynamics of sewage conduit, influencing wastewater biodegradation [9, 15]

One of the most interesting cases possible to simulate with the presented model is the influence of mean sewage depth H on the process of aerobic sewage biodegradation. This case is so interesting because H considered as a border condition influences on flow velocity, decreasing the time of pollutants transport, and changing the relation between biofilm to the volume of flowing sewage. At the case of high sewage filling the relatively small area of wastewater free surface falls to the huge sewage volume, thus the rate of sewage reaeration is decreased.

Model of gravitational conduit

The numerical model developed on the basis of matrix presented in Table 1 uses kinetic and stoichiometric process parameters of sewage biodegradation, reflects the

saprobies biomass settled sanitation system. The mentioned biomass is being treated as a biological process factor of transformations occurring inside the sanitation conduits and as a progenitor of an active sludge in WWTP.

The complete numerical implementation of a model includes also a module of sewer channel hydrodynamic calculation based on Saint-Venant equation system:

$$\begin{aligned}\frac{\partial U}{\partial t} + U \frac{\partial U}{\partial x} + g \frac{\partial H}{\partial x} &= g(s - S) \\ \frac{\partial H}{\partial t} + \frac{\partial}{\partial x} (UH) &= 0.\end{aligned}$$

The S parameter included in the above set, describing waves propagation in open channels at their unit width, may be written as follows:

$$S = \frac{n^2}{H^{4/3}} |U| U.$$

However, in engineering practice the other independent variables are commonly used. The flow rate and free surface coordinates are used instead of flow velocity and sewage depth. Considering the influence of velocity distribution diversity at cross section β , and marking the cross section area as A, flow rate as Q, we must notice that considered variables refer to the whole cross section of a pipe and are properly interpreted. So, U is a mean flow velocity at given cross section and S is an inclination of energy line reflected to the whole cross section – connected to the hydraulic radius R_h and roughness coefficient of inner side pipe walls material, which may be presented as [9, 18, 19]:

$$\begin{aligned}U(x, t) &= \frac{1}{A} \iint_A u(x, y, z, t) dA = \frac{Q}{A} \\ S &= \frac{n^2}{R_h^{4/3}} |U| U,\end{aligned}$$

where: R_h – hydraulic radius, which is a relation of cross-section area A to the wetted perimeter O_z – the peripheral length of contact between transported sewage and pipe material.

The results of hydrodynamic calculations allow to obtain the necessary data to simulate the dynamical processes described by the advection–dispersion equation with source element. The source element contains the described above integrated biochemical processes matrix.

The general form of advection-dispersion transport equation of passive substances for the variable cross-section of the canal can be described in the following way [9, 18, 19]:

$$\frac{\partial}{\partial t}(AC) + \frac{\partial}{\partial x}(QC) - \frac{\partial}{\partial x}\left(AD^D \frac{\partial C}{\partial x}\right) + A\delta = 0,$$

where: $C(x, t) = \int_A c dA / A$ – cross section mean pollution concentration,

$U(x, t) = \int_A u dA / A$ – cross section mean flow velocity,

$Q = UA$ – volumetric flow rate,

A – surface of the active cross section,

D^D – coefficient of longitudinal mass dispersion,

δ – source part determining the intensity of generation or pollution decline in sewage.

Assuming that no side inflows occur it is possible to write:

$$\frac{\partial C}{\partial t} + U \frac{\partial C}{\partial x} - \frac{1}{A} \frac{\partial}{\partial x}\left(D^D A \frac{\partial C}{\partial x}\right) + \delta = 0,$$

where: δ – in presented model could be represented by processes described in Table 1.

To present results of simulations in understandable form it is necessary to chose only the most important parameters which we want to analyze. In the described numerical model it is possible to examination influence more than 20 input parameters on biodegradation processes in sewer. During the results visualization the most convenient way of data presentation is to plot pollutants fraction changes in the function of sewer pipe length or other process parameter.

Summary and conclusions

The presented model, makes possible demonstration of the dynamics of pollutants load change delivered to the wastewater treatment plant through interceptor of a sewage system. It can be also used to predict influence of combined sewer overflows on receiving waters.

The simultaneous modelling of sewage flow and biochemical processes allows to get more precise determination of heterotrophic microorganisms development conditions, both in suspended biomass and biofilm attached to pipe walls.

The determination of pollutants transformations degree due to known conduit shape and length as well as flow parameters, is thus possible.

This property enables an easy adaptation of the presented numerical model to simulation of biodegradation processes of sewage characterized by the different physical and chemical parameters and transported through sanitation conduits of known geometry.

This paper, basing on the previous achievements, is a case study to create a model describing the process of aerobic biodegradation of urban sewage running in gravity sewer in the presence of saprobe biomass.

References

- [1] Pomeroy R. D. and Parkhurs J. D.: Self-purification in Sewers. VI Int. Conf., Advance in Water Pollution Research – Jerusalem. Pergamon Press, Oxford–New York–Toronto–Sydney–Braunschweig 1973, 291–308.
- [2] Stelmach K.: *Charakterystyka przemian BZT₅ i związków fosforu w sieci kanalizacji sanitarnej*. II Ogólnopolska Konferencja “Chemia w ochronie Środowiska”, Wyd. Polit. Lubelskiej, Lublin, 1993, pp. 173–177.
- [3] Stelmach K., Malicki J. and Bonetyński K.: *Kolektory – rozcieńczanie czy redukcja BZT₅ i biogenów*. Materiały Międzynarod. Konf. Nauk.-Techn., Współczesne problemy gospodarki wodno-ściekowej, Wyd. WSI Koszalin, Koszalin–Kołobrzeg, 1995, pp. 429–434.
- [4] Almeida M.C., Butler D. and Davies J.W.: *Modelling in-sewer changes in wastewater quality under aerobic conditions*. Water Sci. Technol. 1999, **39**(9), 63–71.
- [5] Ashley R.M., Hvitved-Jacobsen T. and Bertrand-Krajewski J.: *Quo vadis sewer process modeling?*. Water Sci. Technol. 1999, **39**(9), 9–22.
- [6] Huisman J.L.: *Transport and transformation process in combined sewers*. IHW Schriftenreihe 2001, **10**, 1–180.
- [7] Hvitved-Jacobsen T.: *Sewer Processes. Microbial and Chemical Process Engineering of Sewer Networks*. CRC PRESS, Boca Raton–London–New York–Washington 2002.
- [8] Warith M.A., Kennedy K. and Reitsma R.: *Use of sanitary sewers as wastewater pre-treatment systems*. Waste Manage. 1998, **18**, 235–247.
- [9] Łagód G.: *Modelowanie procesów biodegradacji ścieków w kolektorach kanalizacji grawitacyjnej*. Praca doktorska, Lublin 2007.
- [10] Hvitved-Jacobsen T., Vollertsen J. and Nielsen P.H.: *A process and model concept for microbial wastewater transformations in gravity sewers*. Water Sci. Technol. 1998, **37**(1), 233–241.
- [11] Henze M., Gujer W., Mino T. and van Loosdrecht M.: *Activated sludge models ASM1, ASM2, ASM2d and ASM3, IWA task group on mathematical modelling for design and operation of biological wastewater treatment*. IWA Publishing, London 2002.
- [12] Hvitved-Jacobsen T., Vollertsen J. and Nielsen P.H.: *Koncepcja procesu i modelu dla przemian mikrobiologicznych zachodzących w ściekach w kanalizacjach grawitacyjnych*. Mater. Międzynarod. Konf. Nauk.-Techn. nt. Usuwanie związków biogenych ze ścieków, Kraków 1997, pp. 227–239.
- [13] Shanahan P., Borchardt D., Henze M., Rauch W., Reichert P., Somlyódy L. and Vanrolleghem P.: *River water quality mode No.1: I Modelling approach*. Water. Sci. Technol. 2001, **43**(5), 1–9.
- [14] Łagód G., Sobczuk H. and Suchorab Z.: *Modelowanie procesów samooczyszczania ścieków*, [in:] II Kongres Inżynierii Środowiska, Monografie Komitetu Inżynierii Środowiska PAN 2005, **32**, 825–833.
- [15] Łagód G. and Sobczuk H.: *Modelowanie wpływu napelnienia kolektora kanalizacji grawitacyjnej na przebieg tlenowych procesów biodegradacji ścieków*. Proc. ECOpole 2007, **1**(1/2), 181–186.
- [16] Vollertsen J. and Hvitved-Jacobsen T.: *Stoichiometric and kinetic model parameters for microbial transformations of suspended solids in combined sewer systems*. Water Res. 1999, **33**, 3127–3141.
- [17] Dąbrowski W.: *Oddziaływanie sieci kanalizacyjnych na środowisko*. Wyd. Politechn. Krakowskiej, Kraków 2004.
- [18] Szymkiewicz R.: *Modelowanie matematyczne przepływów w rzekach i kanałach*. Wyd. Nauk. PWN, Warszawa 2000.
- [19] Zoppou C.: *Review of urban storm water models*. Environ. Modell. Software 2001, **16**, 195–231.
- [20] Łagód G., Sobczuk H. and Suchorab Z.: *Modelling of pollutants biodegradation in gravity sewer system*. Ecol. Chem. Eng. A 2008, **15**(11), 1283–1291.

**WPLYW NAPEŁNIENIA KOLEKTORA KANALIZACJI GRAWITACYJNEJ
NA PRZEBIEG TLENOWYCH PROCESÓW BIODEGRADACJI ZANIECZYSZCZEŃ**

Wydział Inżynierii Środowiska
Politechnika Lubelska

Abstrakt: W grawitacyjnych systemach kanalizacyjnych zachodzą procesy zarówno fizyczne, chemiczne, jak i biologiczne. Biodegradacja ścieków, prowadząca do rzeczywistego ubytku ładunku zanieczyszczeń podczas ich przepływu w kanalizacji, jest ważnym procesem zmieniającym ilość i jakość niesionych zanieczyszczeń. Stąd też kolektor grawitacyjny powinien być traktowany zarówno jako tlenowo-beztlenowy reaktor biologiczny, jak i urządzenie do zbierania i transportu ścieków. W prezentowanej pracy proces biodegradacji ścieków opisano za pomocą modelu matematycznego wzrostu i rozwoju populacji mikroorganizmów, który stanowi człon źródłowy w równaniu adwekcji-dyferencji. Parametry hydrodynamiczne powiązane z wysokością napelnienia kolektora grawitacyjnego systemu kanalizacyjnego, wykorzystywane w symulacjach, są obliczane za pomocą równania Saint-Venanta. Prezentowany model może być pomocny podczas określania dynamiki zmian ładunków zanieczyszczeń dopływających do oczyszczalni poprzez kolektory systemu kanalizacyjnego oraz prognozowania oddziaływania przelewów burzowych na wody odbiornika.

Słowa kluczowe: błona biologiczna, kanalizacja grawitacyjna, biodegradacja ścieków w kanalizacji

Zbigniew SUCHORAB¹, Agnieszka ŻELAZNA²
and Henryk SOBCZUK³

WATER CONTENT MEASUREMENT OF BUILDING MATERIALS USING SURFACE TDR PROBE

POMIARY WILGOTNOŚCI MATERIAŁÓW BUDOWLANYCH Z ZASTOSOWANIEM POWIERZCHNIOWEJ SONDY TDR

Abstract: Water present in external walls is one of the basic factors curtailing the function of buildings. Its negative influence should be evaluated both in the constructional and hygienic aspects. It is caused by the fact that water is not only the cause of successive destruction of buildings' construction, but also composes the base for the growth of microorganisms and moulds. Such a problem is typical for the buildings without moisture check or monitoring and causes the respiratory system illnesses, infections, allergies, eyes and skin sensitizations. The buildings affected by the problem of moisture in most cases are stricken with the Sick Building Syndrome, which is caused by the use of not human-friendly materials, defective ventilation or high moisture previously mentioned. Presence of water in building envelopes in moderate climate is a normal and practically inevitable phenomenon. The problem of external barriers moisture becomes important in case of high moisture content. It is especially caused by the improper horizontal damp insulation and mainly observed in many historical buildings or sometimes, even new ones. Other causes of high water content in building barriers are floods, heavy rains or sanitary systems faults. Water contained in building barriers in high content is especially dangerous during winter seasons when numerous freezing and thawing causes building material disintegration. Presence of water in external walls significantly diminishes their thermal isolation, what induces the increased heat loss in cold season, reduction of perceptible temperature and thermal comfort of occupants. All the previously mentioned negative aspects of water influence on the buildings cause the need to find the precise, user-friendly method of water content evaluation in the walls. One of them is TDR (*Time Domain Reflectometry*). This technique bases on the measurement of the electromagnetic pulse propagation velocity in examined medium. The dielectric constant of the material (determined with the TDR device) is the base for its moisture content estimation. The TDR method has got a lot of advantages like high monitoring potential, insensitivity to the salinity, relatively simple service, and has been used in moisture measurements of porous materials, especially of the soils, for many years. By now, this technique has not found the common implementation in the building industry which is caused by its invasive character – it requires the installation of the steel rods in the examined medium, which sets many problems in case of building materials and

¹ Faculty of Environmental Engineering, Lublin University of Technology, ul. Nadbystrzycka 40B, 20–618 Lublin, Poland, phone +48 81 538 43 22, email: Z.Suchorab@wis.pol.lublin.pl

² Faculty of Environmental Engineering, Lublin University of Technology, ul. Nadbystrzycka 40B, 20–618 Lublin, Poland, phone +48 81 538 43 22, email: A.Jedut@wis.pol.lublin.pl

³ Faculty of Environmental Engineering, Lublin University of Technology, ul. Nadbystrzycka 40B, 20–618 Lublin, Poland, phone +48 81 538 44 81, email: H.Sobczuk@wis.pol.lublin.pl

envelopes. The aim of this paper is to propose the alternative idea of the TDR probe – surface probe, which enables the moisture measurements of hard building materials and envelopes. For these materials, the use of classical probe is difficult to realize, because of problems with the introduction of the steel rods in the examined medium. This, modified, TDR method enables the effective moisture measurements without the need to destroy the building barriers structure.

Keywords: building materials, building barriers, building envelopes, moisture, reflectometric moisture measurement methods, dielectric methods, TDR, *Time Domain Reflectometry*, surface TDR probe

The TDR method was first applied for electric cables discontinuities detection [1, 2]. It was realized by measurement of the electromagnetic signal propagation velocity and the period between sending the signal and its return indicated the discontinuity position. Development of electronics in 1970s allowed application of that idea in a reverse mode and formulization of the base for moisture measurement with this method in geo-technical sciences, agriculture and environmental engineering [3]. With the known transmission line length (rods of the probe), measurement of the signal propagation velocity enabled determination of the dielectric permittivity value of the surrounding porous material and thus its moisture.

Most of geomaterials, soils and building materials are the porous media which means that they are formed by at least three phases: solid matrix, air and water. This assumption strongly influences the idea of moisture TDR measurements. Dielectric permittivity, often called the dielectric constant is an electric parameter of materials, which in case of porous media, strongly depends on water content [2, 3]. This is mainly caused by the asymmetric distribution of electric charge in water molecules which form the electric dipoles with the dipole moment equal $6.216 \cdot 10^{-30} \text{ C} \cdot \text{m}$ [4]. External, alternating electromagnetic field, in this case generated by the TDR device, forces the water dipoles to order their directions. Because of that water permittivity is much higher than that of most liquids and solids. It is assumed that the dielectric permittivity for the solid phase varies between 1 and 4 depending on chemical composition or structure. Dielectric constant of the air is equal to 1 and for water is about 80 [5]. This significant difference of dielectric parameters between water and the other phases is the base for moisture determinations of porous hygric materials.

Dielectric permittivity of the porous material from the physical point of view is a complex number and can be split into the real and the imaginary part. Real part ϵ' represents the amount of the stored energy in an alternating electrical field and is the major parameter considered in moisture measurement of porous materials. The imaginary part ϵ'' represents energy loss caused by the electrical conductivity depending on salinity. Such a dielectric permittivity in saline medium can be described by the following complex formula [2, 4]:

$$\epsilon_{\omega} = \epsilon'_{\omega} - i \left(\epsilon''_{\omega} + \frac{\sigma_0}{\epsilon_0 \omega} \right) \quad (1)$$

where: ϵ'_{ω} – real part of dielectric permittivity of medium at relevant frequency ω [-],

ϵ''_{ω} – imaginary part of the dielectric permittivity of medium at relevant

- frequency ω [-],
 i – imaginary unit,
 σ_0 – electrical conductivity [S],
 ϵ_0 – dielectric permittivity of vacuum ($\epsilon_0 = 8.85 \cdot 10^{-12}$ [F m⁻¹]),
 ω – angular frequency [Hz] of the external electric field.

Taking into consideration that the frequency range applied in the TDR moisture technique is around 1000 MHz it is assumed that the energy loss connected with ionic electrical conductivity have no influence on the TDR readouts, and only the real part of the electrical permittivity is meaningful and can be calculated from the following formula [2]:

$$\epsilon = \epsilon_\omega = \left(\frac{c}{V}\right)^2 \quad (2)$$

where: c – velocity of light in a vacuum [$3 \cdot 10^8$ m s⁻¹],
 V – electromagnetic pulse velocity [m s⁻¹] along the rods of the TDR probes.

Pulse propagation velocity can be determined with the TDR equipment measuring the signal transmission and the echo received, using the following formula:

$$V = \frac{2L}{t_p} \quad (3)$$

where: t_p – time of signal propagation [s] between transmitting and receiving the echo,
 L – length of the waveguide [m] installed in a material (2 in numerator means that the signal travels along rods twice – forward and backward).

The idea of the TDR performance is based on transmitting the short needle pulse along the waveguide inserted into the material and observing the returning echo in form of the reflectogram (Fig. 1). Interpretation (usually automated) of the reflectogram enables determination of the velocity of pulse propagation and the dielectric permittivity. This dielectric permittivity can be then recalculated into moisture using one of

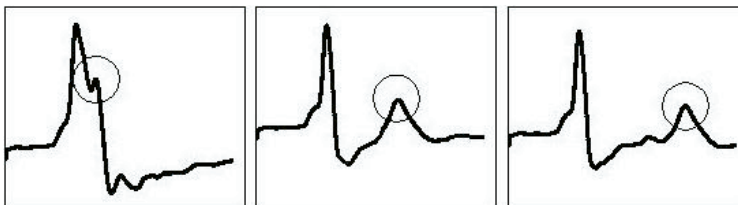

Fig. 1. Reflectograms from TDR probes. Left curve indicates dry material, middle – intermediate states and finally right – water (with the highest value of dielectric constant)

mixing models which can be divided into empirical and theoretical ones. The empirical approach seems to be more popular in the TDR method application but it requires individual material calibration or using the popular empirical formulas by Topp [3]:

$$\theta = \frac{-530 + 292\varepsilon - 5.5\varepsilon^2 + 0.043\varepsilon^3}{10000} \quad (4)$$

or Malicki [6] for example:

$$\theta = \frac{(\varepsilon^{0.5} - 0.819 - 0.168\rho - 0.159\rho^2)}{7.17 + 1.18\rho} \quad (5)$$

where: ε – real part of the dielectric permittivity measured with the TDR equipment,
 ρ – bulk density of the material [g dm^{-3}],
 θ – volumetric water content [vol. %].

Theoretical approach assumes the porous material as a three phase mixture. The most popular are the α models [4] and de Loor [7] model.

For more than 20 years the TDR method has been successfully applied for moisture determination of soils [1, 3] and has been continuously developed by introducing better calibration methods [6, 8] or technologies. Soils are characterized by loose structure and the invasive measurements with typical TDR probes construction have not been problematic. Figure 2 presents typical constructions of invasive TDR probes built of concentric cable, head and steel rods.

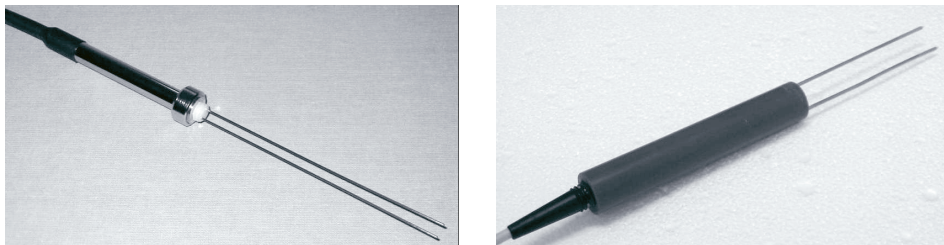

Fig. 2. Typical TDR probes for invasive moisture determinations

The typical TDR probe is an extension of a concentric cable where the core separates from screening and they both transform into the steel rods which are the previously mentioned wave-guides. Part of these rods can be closed in a small resin or plastic cover. The beginning of the probe and also its termination are the specific cable discontinuities which TDR device uses to establish the beginning and the end of the electromagnetic pulse propagation. The TDR device receives the echo of the electromagnetic signal returning from the probe in the form of reflectogram (Fig. 1), and the discontinuities are represented by peaks. The distances between two main peaks vary because of the different dielectric permittivities (due to water content change).

Modifications

As it was mentioned before, the application of classic TDR probes is nearly impossible for rocks or most of building materials which is mainly caused by problems of the steel rods installation. Some experiments have been made on light building materials like aerated concrete [9, 10] but they were mainly conducted in laboratory conditions without any perspectives for field monitoring.

The idea of surface moisture determination is not new – more than 10 year ago Persson and Berndtsson [11] proposed a surface measurement experiment using classic TDR probes covered with suitable dielectric block (Fig. 3) and after suitable readout of effective dielectric permittivity – moisture of the below medium was possible to be estimated.

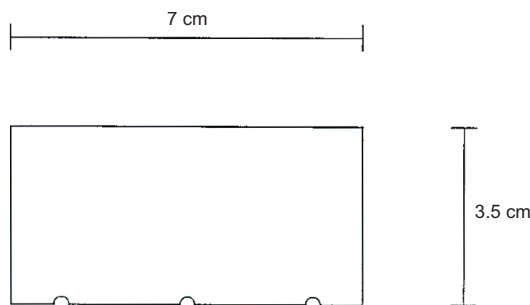

Fig. 3. The surface block for TDR moisture estimation proposed by Persson and Berndtsson in [11]

More advance idea than proposed in [11] is the application of the TDR surface probes, which can be used in moisture determination of building materials or barriers without internal rods installation. The surface probe construction for non-invasive moisture determination was previously proposed in [12] and [13] and some prototype models are presented in Fig. 4.

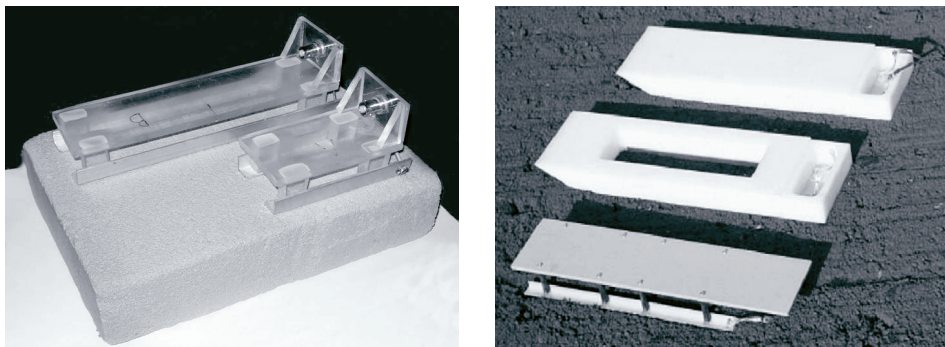

Fig. 4. TDR surface probes: left – for building materials moisture measurement [12], right – TDR surface probes for soil moisture measurement [13]

The probes described in this article are build according to [12] and made of plexi (Fig. 4 left) with aluminum angle bars as the measuring elements. Two presented prototypes where of the same construction but differed in dimensions of the measuring bars. Short probe had the bars 10 cm long and the longer sensor bars were 20 cm long.

Experiment

The experimental setup (Fig. 5) consisted of the following elements:

- TDR device – FOM/mts (*Field Operated Multimeter – Easy Test/Lublin*),
- PC computer as a control station (connected with FOM via RS-232c interface),
- TDR surface probes described above, connected with FOM via concentric cable,
- aerated concrete samples.

Application of the new TDR probes required modification of the TDR device handling – standard operation of FOM TDR device requires only pressing of the buttons and reading out the moisture, or eventually dielectric constant – easily recalculated into moisture with calibration formulas.

For the surface TDR probes a PC computer was used which provided widespread control over the measuring device, and allowed the collection of full reflectograms (not only the simple moisture readouts).

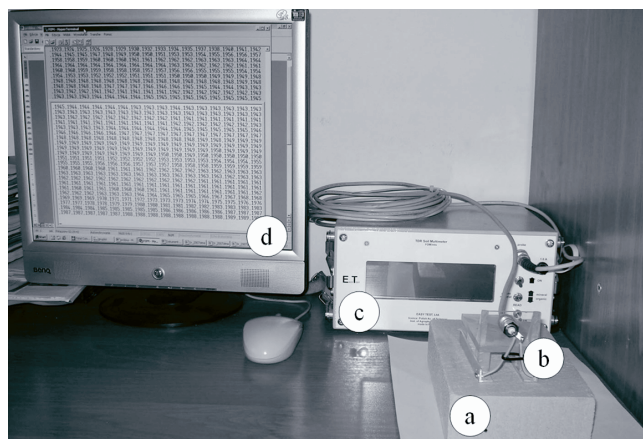

Fig. 5. Measurement setup: a) AAC sample, b) surface TDR probe, c) FOM (TDR device), d) PC display

Three samples of AAC (*aerated autoclaved concrete*) were prepared for examination. They were dried out in the temperature of 105 °C. Surfaces of the samples were polished to provide the maximal probe-material contact and minimize the eventual measurement errors. First sequence of measurements was made on dry samples. Together with the TDR, a sequence of gravimetric measurement was done (to compare the reflectometric readouts with the gravimetric ones). Then the samples were moistened and another sequence of measurements was done. Each cycle was repeated several times until the samples of AAC were saturated.

Results and discussion

For each water content of the sample a reflectometric measurement was done. Diagrams below (Fig. 6) represent the TDR readouts from the surface probe with different water contents. It is clearly visible that first positive peak is located at the same place of each reflectogram and it indicates the beginning of the probe. The second one is shifted to right on each reflectogram which means that the signal needed more time to return from the end of the probe. The velocity of the signal changed (slowed down) because of the rise of the dielectric permittivity. It was caused by increasing water content in the examined AAC samples.

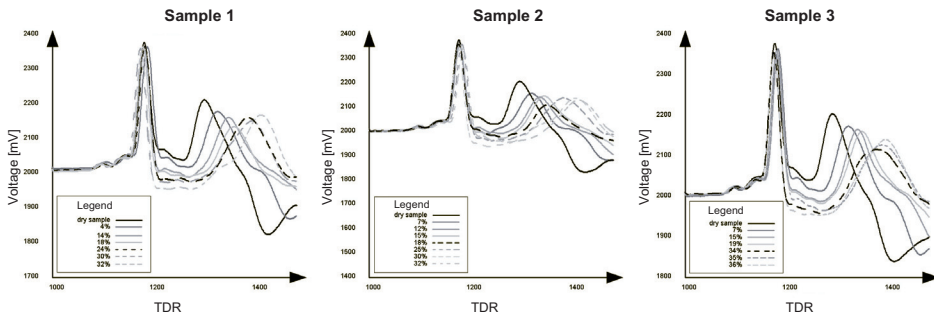

Fig. 6. TDR curves collected from surface probes on three different samples

A special program was prepared to analyze the reflectograms externally out of the device. The aim of the program was to find the voltage extremes determining the beginning and the end of the probe. Distances between the first and the second peak were expressed in time unit (nanoseconds or picoseconds) and allowed determination of the dielectric permittivity using the following formula [2]:

$$\varepsilon = \frac{c \cdot t_p}{2 \cdot L} \quad (6)$$

where: ε – effective dielectric permittivity read by the surface TDR probe [-],
 c – light velocity in vacuum [m s^{-1}],
 t_p – electromagnetic pulse propagation time [s],
 L – length of measuring bars of the surface probe [m].

This enabled finding the dependence between the dielectric constant read by the surface TDR probe and the samples moisture. The results are presented in Fig. 7.

Effective dielectric permittivity determined in above described way shares the fractions of dielectric permittivities of water inside the concrete pores, air inside the pores, solid phase and the ambient air covering the sensors of the probe along the surfaces not touching the examined material. It should be underlined that ambient air share is always constant, independently on examined material moisture, that is why

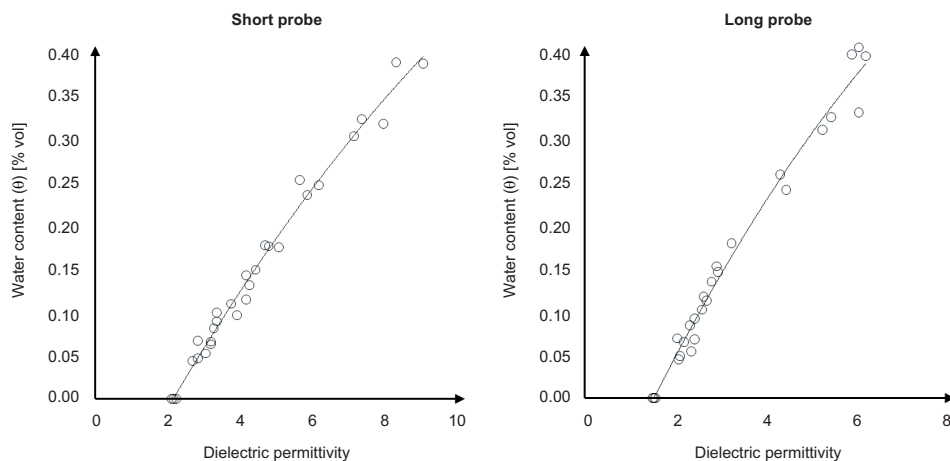

Fig. 7. Dependences between water content and dielectric constant determined with Time Domain Reflectometry for short surface probe (left diagram) and the long surface probe (right diagram)

it can be covered in suitable calibration formulas of particular surface probe construction.

Basing on the research run and the formula (6) the following calibration dependences were established for the described surface probes. For the short probe:

$$\theta_{\text{TDR}} = \frac{-19.4\varepsilon^2 + 791.4\varepsilon - 16000}{10000} \quad (7)$$

where: θ_{TDR} – volumetric water content measured with TDR [vol. %],
 ε – effective dielectric permittivity determined with particular TDR probe construction [-].

Correlation factor for above presented formula was $r = 0.993$.
 For the longer version of the sensor:

$$\theta_{\text{TDR}} = \frac{-446\varepsilon^2 + 1167.9\varepsilon - 1665.4}{10000} \quad (8)$$

with the correlation factor r equal 0.991.

Calibration dependences presented in formulas (7) and (8) and the curves in Fig. 7 differ in particular details. These differences are the results of the shares of ambient air on the measuring bar exposition. For the longer version of the sensor, the ambient air (with the dielectric permittivity equal 1) influence is greater than shorter version. This explains the differences in effective dielectric permittivity readouts of completely dry aerated autoclaved concrete (for short probe more than 2, for long about 1.5).

Conclusions

TDR technology is a good option for moisture measurement of the porous media. The major advantages of the method are high monitoring potential and good accuracy.

Presented probes constructions enable non-invasive reflectometric measurements of building materials. The advantage of the longer probe is better resolution which is the result of the TDR device properties and the sensors dimensions. For the applied TDR device – LOM and the long probe the resolution is 0.3 %vol and for the short one is almost twice worse and equals 0.6 %.

It seems that introduction of the surface TDR probes has a high potential in moisture measurements of the building barriers and materials. It enables to avoid the problems of probes installation. This article presents the possibility of application of the surface TDR probes, which can be used externally and not invasively on building materials or barriers.

Application of the probes of following construction requires a special calibration for each specimen separately, but it can offer a high potential for laboratory and *in situ* measurements.

Acknowledgement

This work was supported by the Ministry of Science and Higher Education of Poland, No. 4952/B/T02/2008/34.

References

- [1] O'Connor K.M. and Dowding C.H.: *GeoMeasurements by Pulsing Cables and Probes*. CRC Press, Boca Raton, Florida, USA 1999.
- [2] Sobczuk H. and Plagge R.: Time domain reflectometry method in environmental measurements, *Monografie Komitetu Inżynierii Środowiska Polskiej Akademii Nauk*, **39**, Lublin 2007.
- [3] Topp G.C., Davis J.L. and Annan A.P.: *Electromagnetic determination of soil water content: Measurements in coaxial transmission lines*. *Water Resour. Res.* 1980, **16**, 574–582.
- [4] Skierucha W. and Malicki M.A.: TDR Method for the measurement of water content and salinity of porous media, *Institute of Agrophysics. Polish Academy of Sciences, Lublin* 2004.
- [5] Dorf R.C.: *CRC Handbook of Engineering Tables*. CRC Press LLC, Boca Raton, Florida, USA 2004.
- [6] Malicki M.A., Plagge R. and Roth C.H.: *Improving the calibration of dielectric TDR soil moisture determination taking into account the solid soil*. *Eur. J. Soil Sci.* 1996, **47**, 357–366.
- [7] De Loor G.P.: *Dielectric properties of heterogeneous mixtures containing water*. *J. Microwave Power*, 1968, **3**, 67–73.
- [8] Ren T., Noborio K. and Horton R.: *Measuring Soil Water Content, Electrical Conductivity, and Thermal Properties with a Thermo-Time Domain Reflectometry Probe*. *Soil Sci. Soc. Amer. J.* 1999, **63**, 450–457.
- [9] Hansen E.J. de P. and Hansen M.H.: *TDR measurement of moisture content in aerated concrete*. *Building Phys.* 2002, 6th Nordic Symposium, 381–388.
- [10] Suchorab Z., Sobczuk H., Łągód G., Pavlik Z. and Cerny R.: *Zastosowanie metody TDR do pomiaru wilgotności materiałów budowlanych*. *Monografie Komitetu Inżynierii Środowiska PAN* 2005, **2**, 1063–1070.
- [11] Perrson M. and Berndtsson R.: *Noninvasive water content and electrical conductivity laboratory measurements using Time Domain Reflectometry*. *Soil Sci. Soc. Amer. J.* 1998, **62**, 1471–1476.
- [12] Sobczuk H.: *Sonda do pomiaru wilgotności ośrodków porowatych, zwłaszcza materiałów budowlanych*. Patent nr 198492 B1 z dnia 30.06.2008.

- [13] Wraith J.M., Robinson D.A., Jones S.B. and Long D.S.: *Spatially characterizing apparent electrical conductivity and water content of surface soils with time domain reflectometry*. Comput. Electron. Agricult. 2005, **46**, 239–261.

POMIARY WILGOTNOŚCI MATERIAŁÓW BUDOWLANYCH Z ZASTOSOWANIEM POWIERZCHNIOWEJ SONDY TDR

Wydział Inżynierii Środowiska
Politechnika Lubelska

Abstrakt: Woda zawarta w zewnętrznych przegrodach budowlanych należy do podstawowych czynników ograniczających funkcjonowanie budynków. Jej negatywny wpływ na obiekty należy oceniać zarówno ze względów konstrukcyjnych, jak i higieniczno-sanitarnych. Duża wilgotność przegród budowlanych jest przyczyną sukcesywnego niszczenia konstrukcji budynków (krystalizacja soli, wielokrotne procesy zamrażania i rozmarzania w okresie zimowym, rozkład drewna oraz przyspieszona korozja stalowych elementów zbrojeniowych). Woda, w sposób pośredni, wywołuje negatywny wpływ na środowisko wewnętrzne pomieszczeń, tworząc podłoże do rozwoju szkodliwych mikroorganizmów oraz grzybów pleśniowych. Jest to problem typowy dla obiektów z nieregulowaną i niemonitorowaną wilgotnością przegród, będący przyczyną chorób dróg oddechowych, infekcji, alergii oraz podrażnień oczu i skóry. Obiekty dotknięte problemem zawilgocenia przegród zewnętrznych w większości przypadków określamy jako dotknięte zespołem chorego budynku SBS (*Sick Building Syndrome*), którego przyczyną jest zastosowanie nieprzyjaznych człowiekowi materiałów budowlanych, wadliwa wentylacja lub właśnie nadmierne zawilgocenie przegród. Woda w przegrodach budowlanych w znaczący sposób obniża ich charakterystyki cieplne, co w konsekwencji prowadzi do zwiększonych strat ciepła w sezonie grzewczym, obniżenia temperatury odczuwalnej, obniżenia komfortu cieplnego pomieszczeń. Wszystkie wyżej przedstawione negatywne aspekty wpływu wody na obiekty budowlane stwarzają potrzebę znalezienia precyzyjnej i możliwie łatwej metody oceny zawartości wody w przegrodach. Do takich metod zaliczamy reflektometryczną metodę pomiaru wilgotności TDR (*Time Domain Reflectometry*). Funkcjonowanie tej techniki oparte jest na pomiarze prędkości propagacji impulsu elektromagnetycznego w badanym materiale. Wyznaczona ze znanej zależności względna stała dielektryczna materiału jest podstawą do ustalenia jego wilgotności. Metoda ta ma wiele zalet (możliwość ciągłego monitoringu, brak wrażliwości na zasolenie, stosunkowa prostota obsługi) i od wielu lat stosowana jest do pomiaru wilgotności ośrodków porowatych, a w szczególności ośrodków gruntowych. Nie znalazła ona do tej pory szerokiego zastosowania w dziedzinie budownictwa. Przyczyną tego jest jej inwazyjny charakter – do realizacji pomiaru niezbędne jest wprowadzenie stalowych prętów w badany ośrodek, co stwarza wiele problemów w przypadku materiałów oraz przegród budowlanych. Celem pracy jest przedstawienie alternatywnej konstrukcji – powierzchniowej sondy TDR, która umożliwi pomiary wilgotności materiałów oraz przegród budowlanych charakteryzujących się znaczną twardością, dla których zastosowanie klasycznej, dwuprętowej sondy, wymagającej wprowadzenia stalowych prętów w badany ośrodek jest trudne do zrealizowania. Metoda ta umożliwi skuteczne pomiary wilgotności bez konieczności niszczenia konstrukcji przegrody.

Słowa kluczowe: materiały budowlane, wilgotność przegród budowlanych, reflektometryczne metody pomiaru wilgotności, metody dielektryczne, TDR (*Time Domain Reflectometry*), powierzchniowa sonda TDR

Lidia WOLNY¹ and Anna KORZEKWA-WOJTAL¹

**EFFECT OF POLYELECTROLYTE DOSE
ON THE CHARACTERISTICS OF SEWAGE SLUDGE
IN SEDIMENTATION PROCESSES
IN SMALL-SIZE WASTEWATER TREATMENT PLANTS**

**WPLYW DAWKI POLIELEKTROLITU
NA CHARAKTERYSTYKI OSADÓW ŚCIEKOWYCH
W PROCESACH SEDYMENTACJI
W MAŁYCH OCZYSZCZALNIACH ŚCIEKÓW**

Abstract: The subject of the article are studies on the characteristics of sewage sludge conditioned with the polyelectrolyte Zetag 7631. Sewage sludge was taken at specified time intervals from the same small-size sewage treatment plant. Based on the capillary suction time test, optimal doses of the applied polyelectrolyte were chosen, for which tests were carried out to describe the effects of gravity thickening and dewatering in the process of centrifuging of the sewage sludge examined. The tests determined that untreated sewage sludge in each case underwent thickening and dewatering poorer than the identical sludge conditioned with polyelectrolyte. Based on the obtained test results, relationship curves for selected parameters characterizing the dewatered sludge were plotted. In addition, microscopic observations of sewage sludge conditioned with the polyelectrolyte chosen for the tests were made. On their basis, a relationship of variations in the conditioned sludge structure on the polyelectrolyte dose was determined.

Keywords: sewage sludge, polyelectrolyte, structure change, gravity thickening, centrifuging, final hydration

Sludge management in small-size sewage treatment plants is presently one of the major problems for rural communes. The growing number of external funds, both domestic and foreign, an particularly the European Union's, creates great opportunities for development. It is becoming the priority for local authorities to build sanitary sewage systems and local sewage treatment plants. Along with investing into environmental protection, problems arise in connection with the disposal of generated wastes, including sewage sludge, which properties are very diverse and dependent on many factors.

¹ Institute of Environmental Engineering, ul. Brzeźnicka 60a, 42–200 Częstochowa, Poland, phone/fax: +48 34 325 09 17, email: annakorzekwa-wojtal@o2.pl, wolny@is.pcz.czyst.pl

The composition and nature of sewage sludge depend on the type of sewage getting to the treatment plant, and on the method of its treatment. Practice shows that there are no two identical sewage sludge [1–3]. Sewage sludge forms a complex multiphase and polydispersion system. It may contain compounds of an organic and mineral nature, in an insoluble, colloidal, and soluble forms. However, the most important characteristics of sewage sludge, which determine their noxiousness, are their amount and hydration [4, 5]. From among the many methods of conditioning, chemical conditioning, including the use of polyelectrolytes, is most often used. So treated sewage sludge more readily undergo sedimentation and thickening in mechanical devices [6, 7]. Recent years have shown an increasing interest in the use of high-molecular weight synthetic polyelectrolytes being regarded as the agents that most effectively aid the processes of sewage sludge pre-treatment before dewatering [8]. Studies carried out so far both home and abroad have shown that polyelectrolytes used in the conditioning of sewage sludge cause an improvement in filtration conditions, thus bringing about changes in their structure. The change of sewage sludge structure results, among other things, in a considerable weakening of the forces bonding water with the surface of solid phase particle, thus facilitating the removal of water in mechanical dewatering processes [9, 10]. An operation which is important for every sewage treatment plant is the proper selection of a polyelectrolyte and its dose, which depends on the type of sewage received by the treatment plant, and the method of sewage treatment. Therefore, the selection of the polyelectrolyte should be made based on experimental tests carried out for each individual sewage treatment plant. An improper selection of the polyelectrolyte dose may result in increased operational costs, and may also impair the result of sewage sludge dewatering [5]. Conditioning agents aid the processes of sewage sludge sedimentation during gravity thickening and dewatering, eg in the processes of sewage sludge centrifuging. Sedimentation is the separation of a suspension into a clear liquid and solid phase particles as a result of particles falling down on the non-porous surface of a tank due to the gravitational force, or other forced motion of particles, caused eg by centrifugal force [11].

Experimental

The experimental part of the study included tests of sewage sludge taken from the sewage sludge stabilization chamber with the aim of describing the physicochemical characteristics of the sewage sludge examined (Table 1), and tests of the same sewage sludge, as conditioned with polyelectrolyte, as well as the monitoring of the conditioning process. The parameters describing the occurring processes were: *capillary suction time* (CST), gravity thickening and hydration in the centrifuging process.

Sewage sludge originating from SBR-type sewage treatment plants of a flow capacity of $Q = 500 \text{ m}^3/\text{day}$ were used for the tests, and were designated with the symbols A, B, C. Sewage sludge were taken at 2.5 months' intervals in 2006, as follows: Sludge A was taken in early January, Sludge B in mid-March, and Sludge C at the end of May. On the sludge sampling day, the percentage of delivered sewage was as follows: for Sludge A, 14 %; for Sludge B, 28 %; and for Sludge C, 5 %.

Table 1

Initial parameters of the examined sludge

No.	Parameter	Unit	Sludge A	Sludge B	Sludge C
1	Colour	—	brown	brown	brown
2	Odour	—	black	black	specific
3	pH	—	7.00	7.90	6.90
4	Initial hydration	%	98.15	92.76	97.56
5	Dry mass (d.m.)	%	1.85	7.24	2.44
6	The content of organic dry mass	% d.m.	74.36	64.36	72.81
7	The content of mineral dry mass	% d.m.	25.64	35.64	27.19
8	CST	s	398.00	150.00	278.00
9	Final hydration	%	94.10	88.70	90.80
10	Resistivity	$\text{m} \cdot \text{kg}^{-1}$	$14.60 \cdot 10^{12}$	$1.28 \cdot 10^{12}$	$8.93 \cdot 10^{12}$
11	Filtration velocity	$\text{m}^3 \cdot \text{s}^{-1}$	0.02	0.03	0.02
12	Filtration capacity	$\text{kg} \cdot \text{m}^{-2} \cdot \text{h}^{-1}$	0.24	3.20	1.84

For treating the sewage sludge, the Zetag 7631, a very strong cationic type polyelectrolyte, was used [12].

The CST measurement was made on a setup consisting of a measuring adapter and a system automatically controlling the time of blotting-paper absorbing the moisture from the sewage sludge after passing between two rings. Based on the capillary suction time test, the range of optimal polyelectrolyte doses was determined.

The microscopic observations of the structure of the sewage sludge under examination were conducted at a 100-times magnification and with a capability to measure the distance between flocs formed and the sewage sludge agglomerates.

The gravity thickening process was conducted in 1000 cm^3 cylinders. The reading of the volume of a separating concentrated sludge layer was taken every 5, 10, 15, 30, 60, 90 and 120 minutes. Based on the measurements of thickened sludge volumes, thickening curves were plotted.

Centrifuging of the sewage sludge was conducted in a periodic-duty laboratory centrifuge with a centrifuging speed and time regulator. The volume of sewage sludge samples subjected to centrifuging was 50 cm^3 . The tests were carried out for a rotational speed of 4500 rpm and a centrifuging time of 5 minutes. The centrifuged sample volume was 50 cm^3 .

Results

Based on the capillary suction time test, the properties and efficiency of the Zetag 7631 polyelectrolyte used in the conditioning process, and the selection of optimal doses were determined. From the curves plotted (Fig. 1), the following polyelectrolyte doses were chosen for the tests: 2.0, 2.5 and 3.0. It follows from Fig. 1 that the capillary suction time for each of the sewage sludge tested decreased with increasing dose of the polyelectrolyte used. Further increasing the polyelectrolyte dose resulted in a further

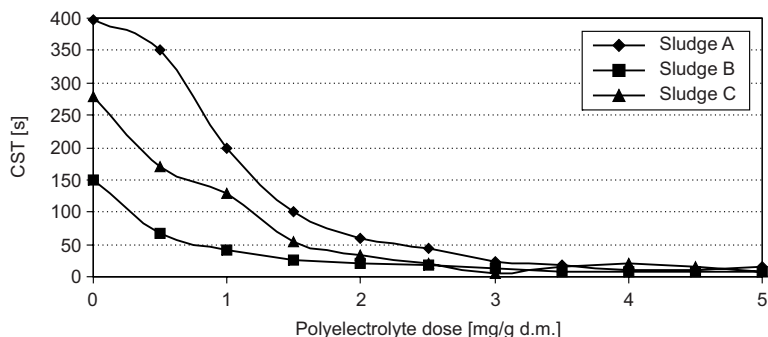

Fig. 1. The influence of polyelectrolyte Zetag 7631 dose on the change of capillary suction time of the examined sludge

decrease in the CST value, but the changes in the sludge structure and the size of flocculi formed, which were observed at the same time, indicated no justification for continuing the increasing of the flocculent quantity (exceeding the break point) [2].

The microscopic photographs of sewage sludge structure (Fig. 2) enable the assessment of the changes occurring in this structure. Observations showed that the polyelectrolyte dose influenced the processes occurring in the sludge. It was found that with the increase in the polyelectrolyte dose, the size of flocculated particles increased.

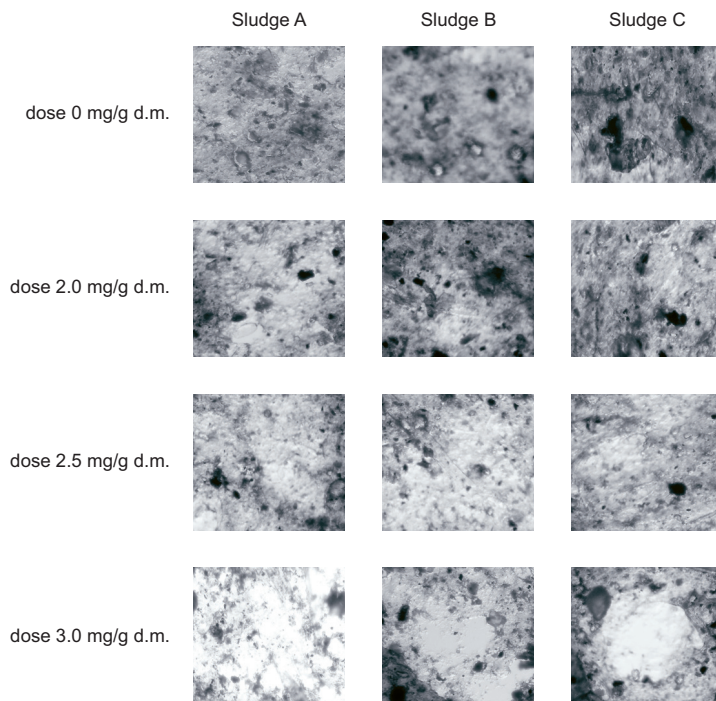

Fig. 2. The structure changes of sludge conditioned by means of Zetag 7631 polyelectrolyte

Untreated sewage sludge showed a finely dispersed structure, and their particles uniformly filled the field of vision. No sludge agglomerates or free water were observed. The conditioning of the sewage sludge with the polyelectrolyte clearly influenced their structure, as compared with untreated sewage sludge. For the dose of 2.0, sludge flocs appeared in the field of vision. The amount of free water present between them increased. The distance between forming floc agglomerates filled with free water was measured. For the dose of 2.0, this value ranged from 8.5 μm to 17 μm ; for the dose of 2.5, from 17 μm to 64 μm ; for the dose of 3.0, from 63 μm to 94 μm (Sludge B) and over 100 μm (Sludge C).

Then, the gravity thickening process was carried out, respectively, for the untreated sludge and for the sludge conditioned with the Zetag 7631 polyelectrolyte in the doses chosen for the tests.

The sewage sludge taken for the tests proved to be very hard to thickening, as during a 2 hours' settling test they underwent sedimentation to a very small extent (the final volume of Sludge A was 995.5 cm^3 ; that of Sludge B was 994 cm^3 ; and of Sludge C, 991.5 cm^3) – Fig. 3.

The settling tests of the sewage sludge for the range of doses determined with the CST test turned out to be more effective for the gravity thickening process. The volume

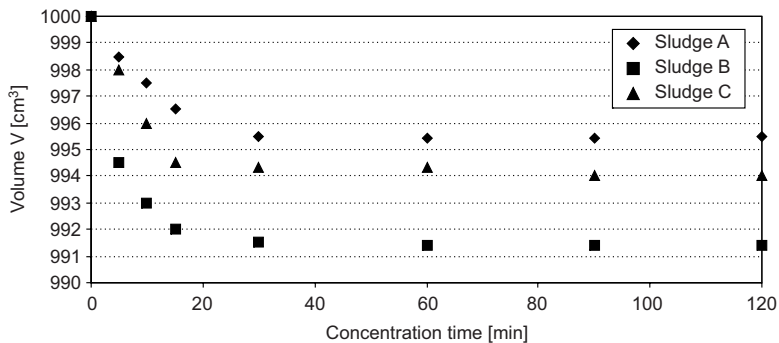

Fig. 3. The course of the gravitational concentration for non-prepared sludge

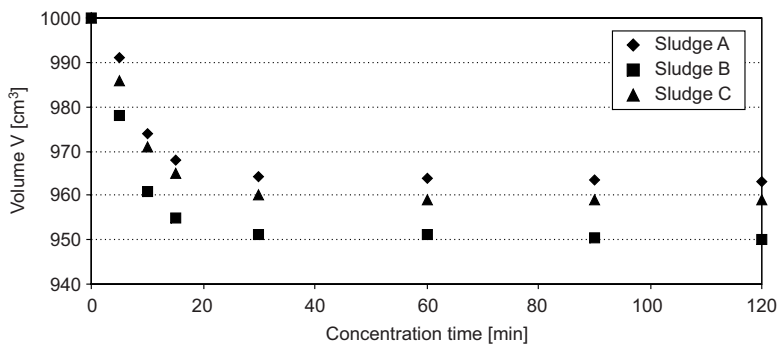

Fig. 4. The course of the gravitational concentration of prepared sludge by means of 2.5 mg/g d.m. dose of polyelectrolyte

of sewage sludge treated with the Zetag 7631 polyelectrolyte in the dose of 2.5 mg/g d.m. after 30 minutes was at a level of 963 cm³ for Sludge A, 950 cm³ for Sludge B, and 959 cm³ for Sludge C.

The course of the sewage sludge thickening test using the dose of 2.5 mg/g d.m. is illustrated in Fig. 4.

The sewage sludge tested were next subjected accelerated sedimentation by centrifuging, and then their final hydration was determined. Variations in the final hydration of sewage sludge in the centrifuging process are shown in Figs. 5 and 6.

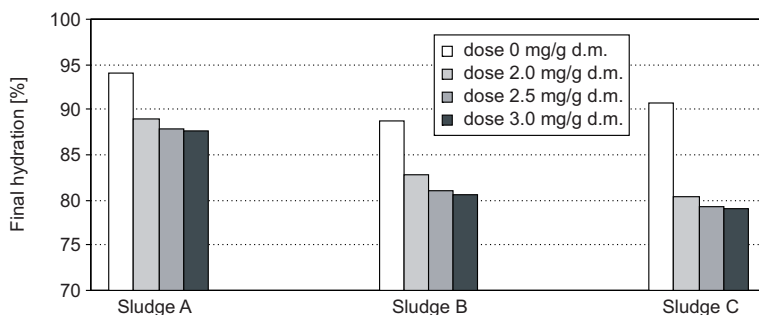

Fig. 5. The final hydration changes of the examined sludge during the centrifuging process

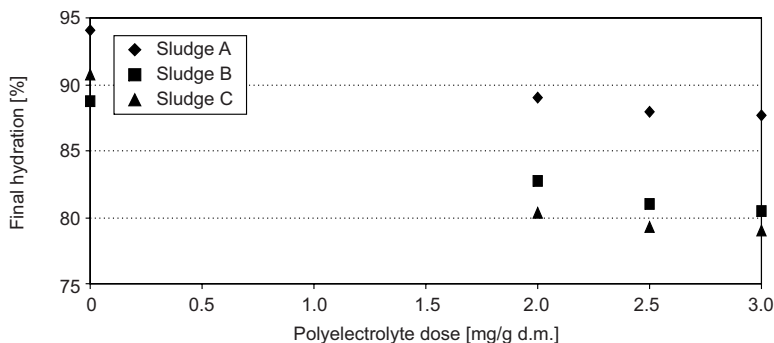

Fig. 6. The comparison of hydration changes of the examined sludge during the centrifuging process

From the obtained test results, an effect of the conditioning agent on the examined parameters was found. The final hydration of untreated sewage sludge in the centrifuging process was, respectively: 94.1 % for Sludge A, 88.7 % for Sludge B, and 90.8 % for Sludge C. The treatment of the sewage sludge with the polyelectrolyte doses caused a reduction in the examined parameter. The final hydration for sewage sludge conditioning with the dose of 2.0 mg/d.m. was, respectively: 89.1 % for Sludge A, 82.8 % for Sludge B, and 80.3 % for Sludge C. The best dewatering effects were obtained for Sludge C. For centrifuged Sludge C, the difference in final hydration between the untreated sludge and the sludge conditioned with the dose of 3.0 mg/g d.m. was 11.8 %.

However, for each of the sewage sludge tested, a dose which definitely influences the effectiveness of dewatering is the dose of 2.5 mg/d.m. The remaining higher doses of the flocculent used reduce the sewage sludge hydration only to a small extent.

Conclusions

- From the investigation carried out, the following conclusions have been drawn:
- sewage sludge taken from the same small-size sewage treatment plant at different time intervals differed in their initial parameters and ability to be gravity thickened and dewatered in a centrifuge;
 - dewatering of the sewage sludge tested by centrifuging progressed favourably, which was found from the obtained results of final hydration;
 - conditioning of sewage sludge before dewatering with fixed doses of polyelectrolyte had the effect of improving the outcome of gravity thickening and dewatering in a centrifuge;
 - only one polyelectrolyte dose, the optimal dose, causes the best reduction of the hydration of sewage sludge that exhibit different initial parameter, though originate from the same sewage treatment plant;
 - for the sewage sludge investigated, there is a relationship between the floc size and agglomerate formation, and the dewatering and thickening ability of sewage sludge.

Acknowledgements

The presented research was financed by BW-401/202/07/P.

References

- [1] Bień J.B.: Osady ściekowe – teoria i praktyka. Wyd. Polit. Częstochowskiej, Częstochowa 2007.
- [2] Wolny L.: Ultradźwiękowe wspomaganie procesu przygotowania osadów ściekowych do odwadniania, Monografie nr 104, Wyd. Polit. Częstochowskiej, Częstochowa 2005.
- [3] Kempa E.S.: *Modelling of wastewater sludges – theoretical conditions and realities*. I Scientific-Technical Conference, Czestochowa, Poland, 1995, 16–23.
- [4] Cywiński B., Gdula S., Kempa E., Kurbiel J. and Płoszański H.: *Oczyszczanie ścieków*, Wyd. Arkady, Warszawa 1983.
- [5] Bień J.B., Bień J.D. and Matysiak B.: *Gospodarka odpadami w oczyszczalniach ścieków*, Wyd. Polit. Częstochowskiej, Częstochowa 1999.
- [6] Anielak A.M.: *Chemiczne i fizykochemiczne oczyszczanie ścieków*, Wyd. Naukowe PWN, Warszawa 2000.
- [7] Bień J., Kowalska E. and Zielewicz E.: *Polielektrolity i ultradźwięki w procesie grawitacyjnego zagęszczania wybranych osadów ściekowych*, Zesz. Nauk. Polit. Śląskiej 1978, Inż. Sanit. **21**, 3–10.
- [8] Nguyen T.P., Hilal N., Hankins N.P. and Novak J.T.: *Characterization of synthetic and activated sludge and conditioning with cationic polyelectrolytes*, Desalination 2008, **227**, 103–110.
- [9] Sozański M.M.: *Technologia usuwania i unieszkodliwiania osadów z uzdatniania wody*, Wyd. Polit. Poznańskiej, Poznań 1999.
- [10] Bień J., Stępnik L. and Wolny L.: *Ultradźwięki w dezynfekcji wody i preparowaniu osadów ściekowych przed ich odwadnianiem*, Monografie nr 37, Wyd. Polit. Częstochowskiej, Częstochowa 1995.

- [11] Bień J.B., Wolny L. and Wolski P.: *Działanie ultradźwięków i polielektrolitów w procesie odwirowania osadów ściekowych*, Inż. Ochr. Środow. 2001, 4(1), 41–50.
- [12] Przegląd produktów Zetag i Magnafloc, Materiały reklamowe, Ciba Specjalty Chemicals, Warszawa 2002.

WPLYW DAWKI POLIELEKTROLITU NA CHARAKTERYSTYKI OSADÓW ŚCIEKOWYCH W PROCESACH SEDYMENTACJI W MAŁYCH OCZYSZCZALNIACH ŚCIEKÓW

Instytut Inżynierii Środowiska, Wydział Inżynierii i Ochrony Środowiska
Politechnika Częstochowska

Abstrakt: Przedstawiono badania dotyczące charakterystyki osadów ściekowych kondycjonowanych polielektrolitem Zetag 7631. Osady pobierane były w danych odstępach czasu z tej samej małej oczyszczalni ścieków. Na podstawie testu czasu ssania kapilarnego dobrano optymalne dawki zastosowanego polielektrolitu, dla których wykonano badania technologiczne opisujące efekty zagęszczania grawitacyjnego i odwadniania w procesie wirowania analizowanych osadów. Badania wykazały, że w każdym przypadku osad niepreparowany zagęszczał i odwadniał się gorzej niż ten sam kondycjonowany polielektrolitem. Na podstawie uzyskanych wyników badań wykreślono krzywe zależności wybranych parametrów charakteryzujących odwadniane osady. Dodatkowo wykonano obserwacje mikroskopowe osadów ściekowych kondycjonowanych wybranym do badań polielektrolitem. Na ich podstawie określono zmiany struktury kondycjonowanego osadu od dawki polielektrolitu.

Słowa kluczowe: osady ściekowe, dawka polielektrolitu, zmiana struktury, zagęszczanie grawitacyjne, wirowanie, uwodnienie końcowe

Anna ŚWIERCZYŃSKA¹, Jolanta BOHDZIEWICZ¹
and Magdalena AMALIO-KOSEL¹

ACTIVITY OF ACTIVATED SLUDGE MICROORGANISMS IN THE CO-TREATMENT OF THE LEACHATES IN THE SBR BIOREACTOR

AKTYWNOŚĆ MIKROORGANIZMÓW OSADU CZYNNEGO W PROCESIE WSPÓŁCZYSZCZANIA ODCIEKÓW W BIOREAKTORZE SBR

Abstract: The aim of the study was to determine the optimum percentage share of leachates co-treated with synthetic wastewaters in biological SBR. The degree of impurities removal and the influence of leachates concentration on activated sludge microorganisms were investigated. Biologically treated wastewaters were cleaned via high-pressure filtration. The percentage share of leachates was changed in the range from 5 vol. % to 30 vol. %. The system was operated in the system of two cycles per day. The main criterion for the estimation of the effectiveness of the treatment process was the change of parameters indicating impurities content in crude and treated wastewaters. All analysis were made according to the Polish standards. Following parameters were analysed: pH, COD, BOD₅, contents of TOC, TC and concentrations of total phosphorus, total nitrogen, nitrate nitrogen and ammonium nitrogen. Additionally, the microscopic analysis of activated sludge was performed, that allowed to determine the influence of the leachates concentration on the amount and diversity of microorganisms present in the aeration chamber and biological activity.

The results revealed that the volume of leachate in the treated mixture should not exceed 5 vol. %. The decrease of values of COD and BOD₅ equal to 92.2 % and 99 %, respectively was observed for such conditions. The increase of leachates share in the treated mixture had a negative influence on the structure and composition of activated sludge flocks what resulted in the decrease of content and diversity of microorganisms.

Keywords: biological SBR, landfill leachates, activated sludge, microorganisms

The deposition of wastes on municipal landfills is the most popular method of their utilization. One of the crucial problems resulting from such a solution is the production of leachates, which are formed during drainage of fall waters through the waste dump [1]. The leachates characterize with the higher concentration of organic and inorganic

¹ Institute of Water and Wastewater Engineering, Silesian University of Technology, ul. S. Konarskiego 18, 44-100 Gliwice, Poland, phone: + 48 32 237 16 98, fax: + 48 32 237 10 47, email: anna.swierczynska@polsl.pl, jolanta.bohdziewicz@polsl.pl

substances in comparison with municipal wastewaters. Additionally, the variation of their amount and qualitative composition as well as low biodegradability causes leachates to be hardly treatable via biological processes. The leachates treatment usually comprises of integrated physico-chemical and biological methods. The choice between various methods needs to be ecologically and economically justified [2, 3]. The biochemical activity of microorganisms is one of the most important elements determining the efficiency of the biological process in the leachates treatment. The introduction of leachates containing toxic substance to municipal wastewaters can cause the atrophy of activated sludge microorganisms and, as a result, preclude the proceeding of biochemical processes. The monitoring of wastewater treatment is usually based on physico-chemical analyses, which do not allow to indicate the reason of process disturbances. The systematic microscopic study of the activated sludge allow to monitor its composition and the structure of flocks, what results in the improvement of treated wastewaters quality [4, 5].

Recently, the application of *Sequential Biological Reactors* (SBRs) in municipal landfill leachates treatment is more often considered. In this technology the cyclic changes of organic compounds and nitrogen concentrations as well as of hydrodynamic conditions (mixing, aeration and release phases) stimulate the growth of microorganisms, which are resistant to environmental conditions. It results in the stabilization of the process, which additionally is more effective in comparison with constant flow treatment. Moreover, the SBR technology can be easily modified already during exploitation eg the length of phases, the method of the feed supply or the total length of the cycle can be changed. It is very important considering the treatment of the leachates, which vary in the amount and composition depending on the season and the waste dump age [2, 3, 6–9].

Materials and methods

The leachate collected at the municipal landfill in Tychy–Urbanowice constituted the substrate of the study. The leachates biological treatment process was carried out in the laboratory conditions with use of the activated sludge taken from the Municipal Sewage Treatment Plant in Gliwice. The experiments were performed in SBR of 3 dm³ in volume and the activated sludge set in the synthetic sewage treatment was used. The operational cycle of the bioreactor took 12 h including: filling and mixing – 4 h, aeration – 7 h, sedimentation and removal of clarified sewage – 1 h. The percentage share of the leachates in the mixture with the synthetic sewage was changed from 5 vol. % to 30 vol. % The effectiveness of the treatment of the sewage and leachates mixtures was compared with the effectiveness of synthetic sewage treatment. The attempt of the treatment of crude leachates was also made. The synthetic sewage were prepared from a broth according to PN-72/C-04550 standard. The characteristic of the leachates and the synthetic sewage is showed in Table 1.

The concentration of the activated sludge was kept at the level of 4 g/dm³, the concentration of oxygen was varied from 3 mg/dm³ to 4 mg/dm³, and the activated

Table 1

The characteristics of the municipall landfill leachates and the synthetic sewage

Parameter	Unit	Leachates	Synthetic sewage	Permissible values*
COD	g O ₂ /m ³	3855	900	125
BOD ₅	g O ₂ /m ³	300	440	25
TOC	g C/m ³	602	198	30
TC	g C/m ³	1580	260	—
Ammonium nitrogen	g N-NH ₄ /m ³	1240	16	10
Nitrate nitrogen	g N-NO ₃ /m ³	9	7	30
Total nitrogen	g N/m ³	1500	120	30
Total phosphorus	g P/m ³	30	15	2
pH	—	8	6.8–7.5	6.5–9.0

* The permissible values of impurities content of sewage disposed to natural reservoirs according to The Regulation of The Minister of Environment, 28.01.2009.

sludge load was equal to 0.1 g COD/g_{dm} d. All analysis were made according to the Polish standards. Following parameters were determined: pH, COD, BOD₅, contents of TOC, TC and concentrations of total phosphorus, total nitrogen, nitrate nitrogen and ammonium nitrogen. The microscopic observation of the activated sludge was made using Opta-Tech N-180 M microscope equipped with the camera. It allowed to determine the amount and kind of microorganisms present in the activated sludge as well to evaluate flocks quality according to their size and structure. The respiratory activity of the activated sludge was also performed.

Results and discussion

The results showing the dependence of the effectiveness of the leachates co-treatment on their volumetric share in the mixture with the synthetic sewage are shown in Table 2.

Table 2

The effectiveness of the leachates co-treatment in the SBR bioreactor depending on their the volumetric share

Share of leaches [vol. %]	Denotation							
	COD [mg/dm ³]	R* [%]	BOD ₅ [mg/dm ³]	R* [%]	TOC [mg/dm ³]	R* [%]	TC [mg/dm ³]	R* [%]
0	35	96.1	2	99.5	19.9	90.0	49	81.2
5	90	92.2	2	99.5	24.8	88.7	54	84.6
10	150	88.0	5	98.3	42.5	81.9	70.5	82.2
20	390	72.7	20	94.6	83.6	67.7	96.7	82.9
30	900	46.9	20	93.9	115.6	61.4	119	85.4

* R – the degree of the parameter decrease.

The degree of removal of impurities during the synthetic sewage treatment was high, and values of the sewage parameters did not exceed the permissible ones defined in the Regulation of The Minister of Environment on conditions to be met for the introduction of sewage into the water and soil from 28th January 2009. The dependence of the degree of removal of COD on the volumetric leachates share in the mixture with the synthetic sewage is shown in Fig. 1.

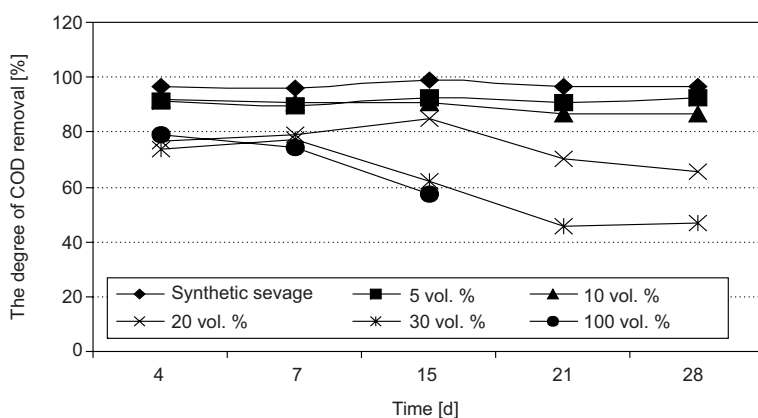

Fig. 1. The dependence of decrease of COD value of co-treated sewage on the co-treatment time and volumetric share

The highest degree of removal of COD during co-treatment of mixture of the leachates and the synthetic sewage was obtained for the leachates share equal to 5 vol. %. The value of the parameter in the treated mixture was 92.2 % lower ($90 \text{ mg O}_2/\text{dm}^3$) in comparison with the crude mixture. For higher shares ie 10 vol. %, 20 vol. % and 30 vol. % the concentration of chemical oxygen demand of the treated mixture was at the level of $150 \text{ mg O}_2/\text{dm}^3$, $390 \text{ mg O}_2/\text{dm}^3$ and $900 \text{ mg O}_2/\text{dm}^3$, respectively, what precluded its direct deposition to the natural collector.

Nevertheless, it was observed that the increase of the volumetric leachates share in the mixture did not influence on the BOD_5 value of the treated mixture, that is shown in Fig. 2. Values of the parameter in bioreactors effluent were low and equal to 2 and $5 \text{ mg}/\text{dm}^3$ for shares 5 vol. % and 10 vol. %, respectively. It corresponded to the decrease of the parameter value by 98.3 % and 99.5 % in comparison with crude mixtures. BOD_5 of treated sewage of 20 vol. % and 30 vol. % leachates share was equal to ca $20 \text{ mg O}_2/\text{dm}^3$.

The similar dependence was observed for the higher concentrations of organic carbon in the crude mixture (Fig. 3).

The degree of removal of TOC was decreasing with the increase of the leachates share in the mixture with the synthetic sewage. After 28 days of the treatment of the mixture containing 5 vol. % of the leachates the concentration of TOC in the treated mixture was equal to $24.7 \text{ mg}/\text{dm}^3$. In case of higher leachates shares the concentration of total organic carbon exceeded the permissible level.

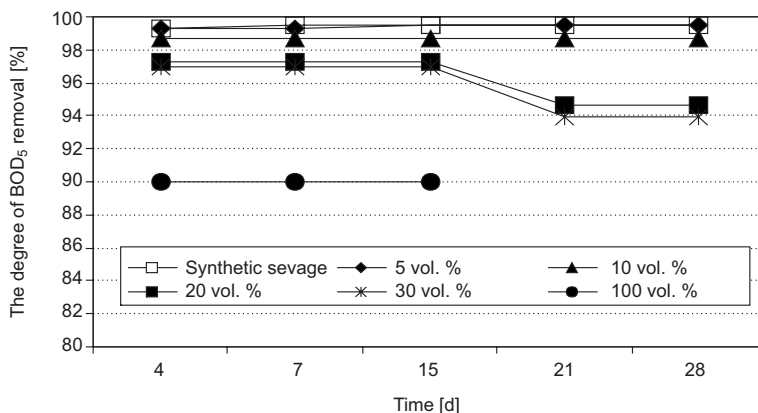

Fig. 2. The dependence of decrease of BOD₅ value of co-treated sewage on the co-treatment time and volumetric share

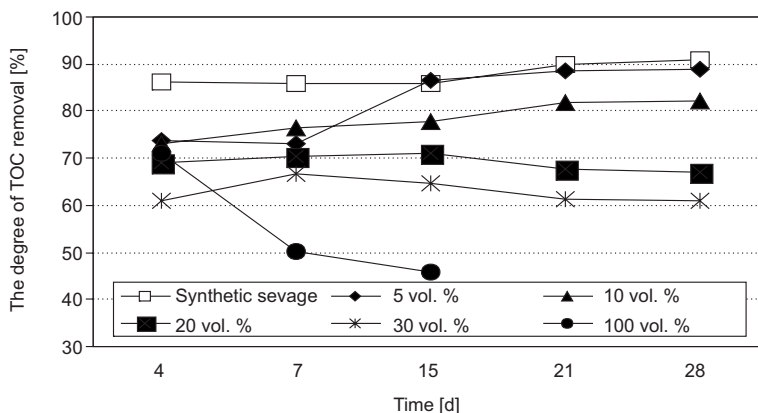

Fig. 3. The dependence of decrease of TOC value of co-treated sewage on the co-treatment time and volumetric share

The change of the concentration of biogenic substances during the co-treatment of the leachates in the SBR depending on their volumetric share is shown in Table 3.

It was revealed, that the degree of the decrease of ammonium nitrogen concentration was high for all mixtures of different leachates shares and exceeded 98%. The concentration of ammonium nitrogen exceeded the permissible level only in case of the treatment of just crude leachates and was equal to 25 mg/dm³. In case of leachates mixtures the parameter values were below the permissible one. However, despite the fact, that the change of the leachates share in the mixture did not influence on the degree of removal of N-NH₄⁺, it caused the significant increase of nitrate nitrogen concentration in the bioreactor effluent, which exceeded the permissible value. The increase of the leachates share in the mixture had also a disadvantageous influence on the effectiveness of removal of total phosphorus. The highest degree of the impurity removal

Table 3

The change of concentration of biogenic elements during leachates co-treatment in the SBR bioreactor depending on their the volumetric share

Share of leachates [vol. %]	Denotation				
	N-NO ₃ ⁻ [mg/dm ³]	N-NH ₄ ⁺ [mg/dm ³]	R* [%]	P _{tot} [mg/dm ³]	R* [%]
0	30	0.5	96.9	2	86.7
5	67	1.0	98.8	4.1	76.2
10	122	1.0	99.3	6.7	64.7
20	328	3.8	99.7	17	19.0
30	340	8.0	99.5	21	12.5

* R – the degree of the parameter decrease.

was obtained for the 5 vol. % share, similarly as in case of NH₄⁺ ions. After 28 days treatment 76.2 % decrease (4.1 mg P_{tot}/dm³) was observed. It was decided, that the biologically treated sewage mixture had to be improved via reverse osmosis (Table 4)

Table 4

The effectiveness of the reverse osmosis process

Parameter	Sewage after SBR [mg/dm ³]	Sewage after RO process	
		Concentration [mg/dm ³]	Retention [%]
COD	90	8.0	91.1
BOD ₅	2	0.0	100
TOC	24.8	3.0	87.9
Ammonia nitrogen	1.0	0.0	100
Nitrate nitrogen	67	7.5	88.8
Total phosphorus	4.1	< 1.0	~99

The applied high-pressure membrane process improved the quality of the treated mixture that it could be disposed to the natural collector. Concentrations of nitrate nitrogen and total phosphorus in the final stream were equal to 7.5 mg/dm³ and less than 0.1 mg/dm³, respectively.

The microscopic observations of the change of activated sludge quality caused by the increase of the leachates share in the mixture were also performed in the study. The evaluation of the amount and the quality of microorganisms present in the crude activated sludge, as well as the analysis of its structure allowed to conclude that it characterized with flocks of medium size considerable cohesion, loose structure, regular shape and significant diversity of microorganisms. It indicated that the proper aerobic conditions were provided, while the presence of floating and creeping ciliates pointed the medium substrate load conditions. The age of the activated sludge was determined as the mature one according to the presence of many *Arcelli* and rotifers. For leachates shares in the range from 5 vol. % to 10 vol. % both, shape and size of flocks remained

unchanged. However, in case of these shares, in the fourth week of bioreactors operation the amount of ciliates, rotifers and *Arcelli* slightly decreased and filamentous bacteria appeared. For higher leachates share the significant decrease in microorganisms diversity was observed. Additionally, the presence of the considerable high amount of filamentous bacteria together with the decrease of the amount of ciliates and *Arcelli* were noted. It explained the decrease of the co-treatment effectiveness in these bioreactors showed by significantly exceeded permissible concentrations of impurities. It was also found, that the increase of the leachates in the mixture resulted in the change of shape and size of flocks, which became smaller and irregular.

In case of the treatment of crude leachates already in the second week of the process a white, rigid foam appeared on the surface of the bioreactor, that indicated on the overload of the activated sludge. The flocks were very fine and of small amount, and the bioreactor effluent was turbid, what confirmed the washing out of the activated sludge. The amount of microorganisms significantly decreased and the presence of filamentous bacteria was noted, what resulted in the ineffective treatment. In the next week of the study activated sludge microorganisms atrophied according to the substrate overload as well as toxicity of chemical compounds present in the leachates.

The obtained dependences of the change of the biochemical activity of activated sludge on the leachates share in the co-treated mixture confirmed microscopic observations. The respiratory activity of the activated sludge adapted for the synthetic sewage treatment was the highest and equal to $30 \text{ mg O}_2/\text{dm}^3$. It slightly decreased for the 5 vol. % leachate share to the level of $28.8 \text{ mg O}_2/\text{dm}^3$. For higher leachates share ie 10 vol. %, 20 vol. % and 30 vol. % values of the respiratory activity were equal to $25.5 \text{ mg O}_2/\text{dm}^3$, $24.2 \text{ mg O}_2/\text{dm}^3$ and $22.8 \text{ mg O}_2/\text{dm}^3$, respectively. In the bioreactor containing only the crude leachates after two weeks of the treatment the respiratory activity was undeterminable.

Conclusions

It was shown that the increase of the leachates in the mixture with synthetic sewage co-treated in the SBR caused the increase of the content of organic substances. The optimal leachates share in the mixture was established at the level of 5 vol. % what enabled the effective removal of organic impurities to the permissible level. However, the treated mixture still characterized with the exceeded concentrations of biogenic substances. It was decided to clean the bioreactor effluent via reverse osmosis.

The applied high-pressure membrane process improved the quality of the treated mixture that it could be disposed to the natural collector. Concentrations of nitrate nitrogen and total phosphorus in the final stream were equal to $7.5 \text{ mg}/\text{dm}^3$ and less than $0.1 \text{ mg}/\text{dm}^3$, respectively.

For the optimal leachates share (5 vol. %) both, shape and size of the activated sludge flocks remained unchanged during the treatment. The increase of the leachates share in the mixture significantly influenced on the flocks quality causing the decrease of both, the amount of flocks and microorganisms diversity.

The performance of the treatment of crude leachates was stopped after 15 days according to the activated sludge atrophy, which resulted in total inhibition of the treatment.

Literature

- [1] Rosik-Dulewska Cz.: Basics of waste management, Scientific Publisher PWN, Warszawa 2002 (in Polish), pp. 148–160.
- [2] Surmacz-Górska J.: *Removal of organic pollutants and nitrogen from leachate produced on municipal landfills*, Sci. Papers Silesian Univ. Technol., Environ. Eng., Gliwice 2000.
- [3] Szyk J., Leachates from municipal landfill, Sci. Publisher Gabriel Borowski, Warszawa 2003, pp. 42–77.
- [4] Buck H.: Microorganisms in activated sludge, “Seidel-Przywecki” Sp. z o.o. Publishers, Szczecin 1999, pp. 7–8.
- [5] Eikelboom D.H.: The handbook of microscopic activated sludge studies, “Seidel-Przywecki” Sp. z o.o. Publishers, Szczecin 1999, pp. 7–13.
- [6] Laitinen N., Luonsi A. and Vilen J.: *Landfill leachate treatment with sequencing batch reactor and membrane bioreactor*, Desalination 2006, **191**, 86–91.
- [7] Tsilogeorgis J., Zouboulis A., Samara P. and Zamboulis D.: *Application of a membrane sequencing batch reactor for landfill leachate treatment*, Desalination 2008, **221**, 483–493.
- [8] Surmacz-Górska J., Miksch K. and Kita T.: *Possibilities of biological treatment of leachate from municipal landfill*, Environ. Protect. Arch. Wrocław 2000, **26**, 42–54.
- [9] Diamadopoulos E., Samaras P., Dabou X. and Sakellaropoulos G.P.: *Combined treatment of landfill leachate and domestic sewage in a sequencing batch reactor*. Water Sci. Technol. 1997, **36**(2–3), 61–68.

AKTYWNOŚĆ MIKROORGANIZMÓW OSADU CZYNNEGO W PROCESIE WSPÓŁCZYSZCZANIA ODCIEKÓW W BIOREAKTORZE SBR

Instytut Inżynierii Środowiska i Energetyki
Politechnika Śląska

Abstrakt: Celem pracy było wyznaczenie najkorzystniejszego udziału procentowego odcieków współczyszczanych ze ściekami syntetycznymi w bioreaktorze SBR. Oceniano stopień usunięcia zanieczyszczeń oraz wpływ stężenia odcieków na metabolizm mikroorganizmów osadu czynnego. Współczyszczone biologicznie odcieki dodatkowo doczyszczono w procesie odwróconej osmozy. Udziały procentowe odcieków zmieniano w zakresie wartości od 5 % obj. do 30 % obj. Układ pracował w systemie dwóch cykli na dobę. Kryterium oceny stopnia oczyszczenia ścieków była zmiana wartości wskaźników zanieczyszczeń charakteryzujących ścieki poddawane procesowi oczyszczania i odprowadzane z bioreaktora. Oznaczenia wykonano zgodnie z obowiązującymi polskimi normami. Wyznaczano: odczyn, ChZT, BZT₅, OWO, OW, stężenia fosforu ogólnego, azotu azotanowego oraz amonowego. Prowadzono również analizę mikroskopową osadu czynnego, oceniając wpływ stężenia odcieków na ilość i rodzaj aktywnych mikroorganizmów zasiedlających komorę napowietrzania. Określano aktywność oddechową biomasy w zależności od warunków prowadzenia procesu współczyszczania odcieków.

Wykazano, że udział procentowy odcieków w mieszaninie ścieków nie powinien przekraczać 5 % obj. Stopień obniżenia wartości wskaźnika ChZT charakteryzującego ścieki oczyszczone w tych warunkach wyniósł 92,2 %, natomiast stężenie BZT₅ kształtowało się na poziomie 99 %. Wzrost stężenia odcieków w mieszaninie ze ściekami syntetycznymi wpłynął negatywnie na strukturę i skład kłaczków osadu czynnego, wywołując obniżenie ilości i różnorodności mikroorganizmów oraz ich aktywności oddechowej.

Słowa kluczowe: bioreaktor SBR, odcieki składowiskowe, osad czynny, mikroorganizmy

Mariusz DUDZIAK¹

EFFECT OF THE CONTACT ANGLE ON THE EFFECTIVENESS OF MYCOESTROGENS REMOVAL FROM WATER USING NANOFILTRATION MEMBRANES

WPLYW KĄTA ZWILŻANIA MEMBRAN NANOFILTRACYJNYCH NA EFEKTYWNOŚĆ USUWANIA MYKOESTROGENÓW Z WODY

Abstract: The research addressed the removal of selected mycoestrogens by nanofiltration using membranes different in membrane casting polymers, degree of NaCl removal and efficiency. It also determined the effect of hydrophobicity of a membrane characterized by the measurement of contact angle on micropollutants retention. The tests were carried out on a new membrane and one modified by inorganic and organic matter. The membrane prepared from cellulose acetate CK characterized by a high contact angle and NaCl removal yielded the highest mycoestrogens retention. The presence of inorganic and organic matter in water reduced membrane efficiency and increased hydrophobicity due to the modification of the membrane surface. Those filtration conditions brought about a change in micropollutants retention.

Keywords: nanofiltration, mycoestrogens, water treatment, removal micropollutants, separation mechanism

Normally, a description of transport and separation properties of nanofiltration membranes supplied by a manufacturer gives information on the removal of $MgSO_4$, range of pH tolerance of a treated solution and determination of a typical flux from a unit membrane surface. Sometimes, it also describes a cut-off expressed in Daltons and type of membrane casting polymers. On the other hand, a description of the physical and chemical properties of membrane surface distinguishes only between hydrophilic and hydrophobic membranes. Membrane hydrophobicity is usually determined by contact angle measurements [1]. Papers [2–3] report that membranes of larger contact angles may both remove and adsorb organic micropollutants more than membranes of smaller contact angles. Our research in this field [4–5] revealed that the removal of NaCl (monovalent ions) is an indicator of sorption and separation abilities of membranes to remove micropollutants.

This work focused on the retention of selected mycoestrogens (zearalenone ZON, α -zearalenol α -Zol, β -zearalenol β -Zol and zearalanol ZAN) by nanofiltration using

¹ Faculty of Energy and Environmental Engineering, Silesian University of Technology, ul. Konarskiego 18, 44–100 Gliwice, Poland, phone: +48 32 237 16 98, fax: +48 32 237 10 47, email: mariusz.dudziak@polsl.pl

membranes that differed in membrane casting polymers, NaCl removal and efficiency. In addition, the membranes were characterized by finding their contact angles with a pocket goniometer. Membrane hydrophobicity and micropollutants retention were determined for a new membrane and one modified by inorganic and organic matter present in filtered water. The tests were aimed at finding the effect of membrane hydrophobicity on micropollutants retention during treatment of aqueous solutions by nanofiltration.

Materials and methods

Four commercial nanofiltration membranes were selected for the tests: CK, DK and HL manufactured by GE Osmonics and NF-27– produced by Dow Filmtec (Table 1). Nanofiltration was carried out in the dead-end mode using a 350 cm³ steel membrane cell (membrane surface area 38.5 cm²) equipped with a magnetic stirrer. The tests were conducted under a transmembrane pressure of 2.0 MPa and a temperature of 20 °C.

Table 1

Characteristics of membrane (manufacturer data)

Membrane type	Material	Removal of MgSO ₄ [%]	Max. pH range	Cut off [Da]	Volumetric flux of deionized water (J _w) ^a , 10 ⁻⁶ [m ³ /m ² s]
CK	cellulose acetate	—	2–8	150–300	11.0
DK	polyamide on polysulfone support	98	1–11		21.4
HL		98	3–9		48.3
NF-270	support	97	2–11	200	58.2

^a J_w obtained in this work at ΔP = 2.0 MPa.

The transport and separation parameters of the nanofiltration membranes were assessed using the equations given in Table 2.

Table 2

Equations used to evaluate membrane properties and removal efficiencies

Parameter, unit	Equations	Number
Volumetric permeate flux (deionized water), J _v (J _w) [m ³ /m ² s]	$J_v(J_w) = \frac{V}{F \cdot t}$	1
Relative permeability of the membrane α [-]	$\alpha = \frac{J_v}{J_w}$	2
Retention coefficient R [%]	$R = \left(1 - \frac{C_p}{C_f}\right) \cdot 100$	3

V – volume [dm³], F – membrane area [m²], t – filtration time [s], C – concentrations [μg/dm³], p – permeate, f – feed.

The determination of nanofiltration effectiveness was based on the measurements of both membrane efficiency (J_v and α) – equations (1 and 2) and selectivity (R) – equation (3). The static contact time was measured with a pocket Fibro System AB PG-1 goniometer.

The tests were conducted on model water prepared from deionized water with and without an addition of inorganic (a mixture of 20 mmol/dm³ NaCl, 1 mmol/dm³ NaHCO₃ and 1 mmol/dm³ CaCl₂) or organic matter (humic acid HA, 30 mg/dm³) and 5 µg/dm³ mycoestrogens standards.

The investigation dealt with the absorbance, conductivity and concentration of particular mycoestrogens. The absorbance (wavelength $\lambda = 254$ nm) was measured with a Jena AG VIS Cecil 1000 UV spectrometer while conductivity was determined with a WTW inoLab[®] Multi 740 laboratory meter. The methodology of mycoestrogens assays covered three steps ie isolation of compounds by SPE (1), derivatization of analytes as a preliminary stage of their determination (2) and quantitative analysis by GC-MS chromatography (3).

The micropollutants were separated from the water matrix using Supelco SPE tube (Supelclean[™] Envi-18, volume 6 cm³, 1.0 g of phase), and their concentrations were determined by *gas chromatography-mass spectrometry* (GC-MS Saturn 2100 T manufactured by Varian). Prior to extraction, the tube bed was conditioned with acetonitrile (5 cm³) and afterwards rinsed with deionized water (5 cm³). The separated compounds were eluted with acetonitrile (4 cm³) and then derivatized after the solvent was vaporized to dryness. Mycoestrogens derivatization was carried out with a three component BSTFA/TMCS/DTE mixture for 5 min at a ratio of 1000:10:2 (v/v/w) and a temperature of 90 °C. A GC-MS quality and quantity analysis of silyl derivatives produced was based on *selected ion monitoring* (SIM), for zearalenone of $m/z = 444, 430, 306$ and 150 , for α -zearalenol and β -zearalenol of $m/z = 446, 432, 414$ and 306 for zearalanone of $m/z = 449, 432, 406$ and 308 . The temperature of the chromatographic furnace was set at 140–280 °C (temperature of injector 300 °C). The chromatographic separation was conducted using a Varian VF-5ms column.

Results and discussion

The retention coefficient for the mycoestrogens largely depends on a removed compound and type of nanofiltration membrane (Fig. 1). The retention of the mycoestrogens fell within 70–97 %. The CK cellulose membrane produced the highest retention. Compared with the other membranes, it was characterized by the highest contact angle of around 54° and high retention of NaCl removal (Table 3), which makes its properties similar to those of reverse osmosis membranes. The presence of mycoestrogens in deionized water did not affect the transport properties of the nanofiltration membranes. The volume permeate flux was similar to the deionized water flux determined during the conditioning stage (Table 1).

Mycoestrogens retention was also investigated during filtration of deionized water with an addition of a mixture of salt or humic acid. Both the inorganic and organic matter brought about a decrease in membrane efficiency ($\alpha < 1$, Fig. 2A) accompanied

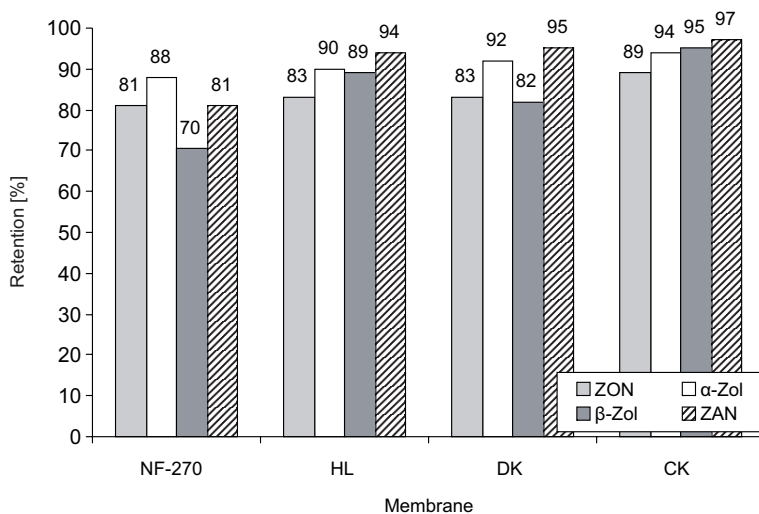

Fig. 1. Retention coefficient of mycoestrogens in nanofiltration

Table 3

Contact angles, NaCl removal and transport properties used membranes

Parameter	Membrane			
	NF-270	HL	DK	CK
Contact angles [°]	17	25	37	54
NaCl removal ^a [%]	41	46	8.0	75
Volumetric permeate flux (J_v), 10^{-6} [m ³ /m ² s]	56.0	48.8	21.8	11.2

^a Determined in experiment during filtration of NaCl solution (1000 mg/dm³) at $\Delta P = 2.0$ MPa.

by an increase in the contact angle (Table 4). The increase was more significant for the NF-270 membrane which was initially characterized by a low contact angle (17°, Table 3). In addition, there was an increase in the effectiveness of organic matter removal during nanofiltration, which was determined by measuring absorbance in the permeate (Fig. 2B). The above observations confirm the modification of the membrane surface. Those filtration conditions also revealed a change in the removal of the mycoestrogens. In most cases, the retention of the compounds decreased, although it did not exceed 7 %, except for the filtration of deionized water with an addition of humic acid using the NF-270 membrane which revealed an increase in micropollutants retention from 12 % to 15 %. That filtration also exhibited the lowest relative permeability of the membrane ($\alpha = 0.77$, Table 4). The presence of humic acid in water intensifies both membrane fouling and formation of HA-mycoestrogens complexes [6] which are more readily retained by the membrane than a single compound due to their larger particles. In the paper [7] it was found that fouling intensifies the adsorption of micropollutants on and in the structure of the membrane, which may also bring about an increase in retention.

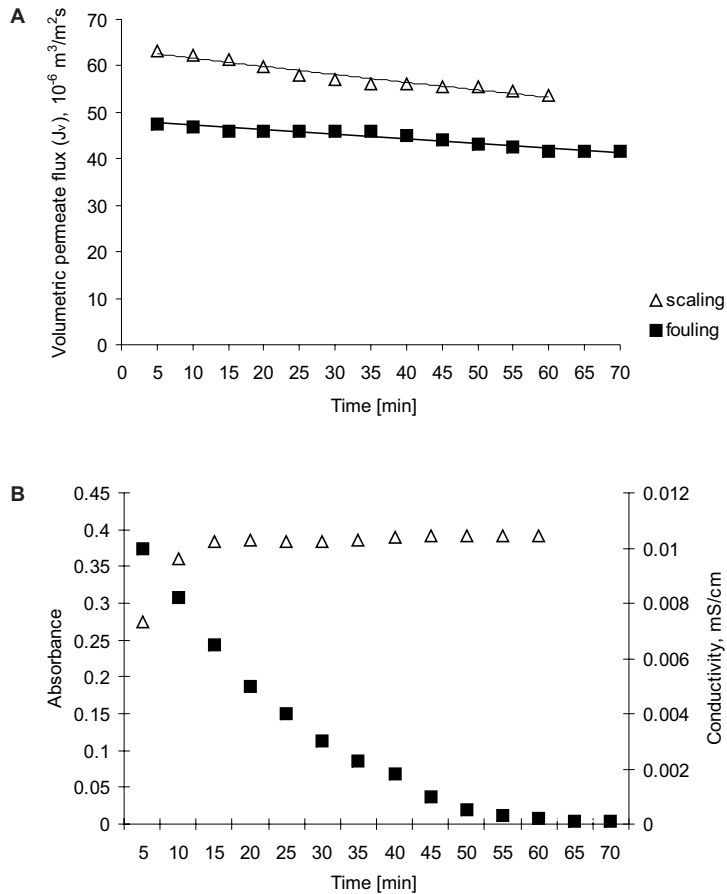

Fig. 2. Volumetric permeate flux and concentration of organic and inorganic substances in permeate under conditions of scaling/fouling experiments (membrane NF-270)

Table 4

Change in retention of mycoestrogens due to inorganic and organic substances occurrences in water

Compound ^a	Membrane			
	NF-270		CK	
	Matrix			
	Deionized water + salts	Deionized water + HA	Deionized water + salts	Deionized water + HA
	Retention (change in retention ^b)			
ZON	78 (-3)	96 (+15)	82 (-7)	88 (-1)
α -Zol	86 (-2)	100 (+12)	92 (-2)	92 (-2)

Table 4 contd.

Compound ^a	Membrane			
	NF-270		CK	
	Matrix			
	Deionized water + salts	Deionized water + HA	Deionized water + salts	Deionized water + HA
	Retention (change in retention ^b)			
Parameter				
Relative permeability of the membrane, α	0.99	0.77	0.79	0.82
Contact angles ^c [°]	48	51	57	58

^a Mycoestrogens concentration 5 $\mu\text{g}/\text{dm}^3$; ^b positive (negative) sign indicates an increase (decrease) in retention; ^c determined after filtration salts or humic acid solutions.

Conclusions

The removal of mycoestrogens during nanofiltration exceeded 70 % and was dependent on the membrane type and composition of the water matrix. The highest retention was found for the cellulose membrane characterized by high contact angles and NaCl removal. The presence of inorganic and organic matter in the treated water may modify the membrane surface and its physical and chemical properties, changing the retention coefficient of micropollutants. The mechanism described herein forms the basis for the differences in micropollutants retention produced both on a bench and technical scale.

Acknowledgement

This work was performed with the financial support from the Polish Ministry of Education and Science under grant no. N N523 5533 38.

References

- [1] Boussu K., Baerdemaeker J., Dauwe C., Weber M., Lynn K.G., Depla D., Aldea S., Vankelecom I.F.J., Vandecasteele C. and Van der Bruggen B.: *Chem. Phys. Chem.* 2007, **8**, 370–379.
- [2] Kimura K., Amy G.L., Drewes J. and Watanabe Y.: *J. Membr. Sci.* 2003, **221**, 89–101.
- [3] Wintgens T., Gallenkemper M. and Melin T.: *Water. Sci. Technol.* 2003, **48**, 127–134.
- [4] Dudziak M. and Bodzek M.: *Desalination* 2009, **240**, 236–243.
- [5] Dudziak M. and Bodzek M.: *Architecture Civil Engineering Environment* 2010, **3**, 95–102.
- [6] Dudziak M. and Bodzek M.: *Chem. Pap.* 2010, **64**, 139–146.
- [7] Dudziak M. and Bodzek M.: *Monogr. Polsk. Akad. Nauk* 2010, **65**, 131–137.

WPLYW KĄTA ZWILŻANIA MEMBRAN NANOFILTRACYJNYCH NA EFEKTYWNOŚĆ USUWANIA MYKOESTROGENÓW Z WODY

Instytut Inżynierii Wody i Ścieków
Politechnika Śląska

Abstrakt: Badano efektywność usuwania wybranych mykoestrogenów w procesie nanofiltracji z użyciem membran różniących się polimerem membranotwórczym, stopniem usunięcia soli NaCl i wydajnością. Określono wpływ hydrofobowości membrany scharakteryzowanej przez pomiar kąta zwilżania na retencję mikrozanieczyszczeń. Badania prowadzono dla membrany nowej i zmodyfikowanej przez substancję nieorganiczną i organiczną. Najwyższą retencję mykoestrogenów odnotowano w przypadku membrany wykonanej z octanu celulozy CK charakteryzującej się dużymi wartościami kąta zwilżania oraz stopnia usuwania soli NaCl. Obecność w wodzie substancji nieorganicznej i organicznej powodowała zmniejszenie wydajności membran oraz wzrost hydrofobowości na skutek modyfikacji powierzchni. W tych warunkach filtracji odnotowano zmianę w retencji mikrozanieczyszczeń.

Słowa kluczowe: nanofiltracja, mykoestrogeny, oczyszczanie wody, usuwanie mikrozanieczyszczeń, mechanizm separacji

Beata ZAŁĘSKA-CHRÓST¹, Lech SMO CZYŃSKI¹
and Regina WARDZYŃSKA¹

TREATMENT OF WASTEWATER FROM THE PULP AND PAPER INDUSTRY BY ELECTROCOAGULATION IN A STATIC SYSTEM

OCZYSZCZANIE ŚCIEKÓW CELULOZOWO-PAPIERNICZYCH METODĄ ELEKTROKOAGULACJI W SYSTEMIE STATYCZNYM

Abstract: Results of the electrochemical treatment of pulp and paper wastewater have been described. The electrolysis was conducted in static system on aluminium electrodes. The wastewater purification was carried out at two values of the current density 3.125 mA/cm² and 6.25 mA/cm². After electrocoagulation the COD, turbidity, suspended solids and color of the supernatant were measured. The fractal dimension of the aggregates-flocs of the sludge obtained was determined, too. The examined process of static electrocoagulation turned out to be an efficient method for pulp and paper wastewater purification. The aggregates-flocs measured were recognized as self-similar objects.

Keywords: electrocoagulation, pulp and paper wastewater, fractal dimension

Electrocoagulation is an increasingly popular method of wastewater treatment. According to numerous authors, it is a highly effective technique for treating farming and industrial wastewater as well as municipal sewage from populated areas. The referenced sources describe attempts at the electrolytic treatment of wastewater from textile plants [1–3], fabric dyeing plants [4], tanneries [5], pulp and paper plants [6], as well as the use of the electrocoagulation process in theoretical models [7, 8]. In most cases, the discussed treatment technique involves Al or Fe electrodes [3, 9–11]. The findings of the cited studies suggest that electrochemical coagulation provides a viable alternative to conventional treatment methods involving chemical coagulation [7, 12, 13].

Owing to the specific production technology, the pulp and paper industry significantly contributes to environmental pollution. It increases the total volume of dust and gas

¹ Department of Chemistry, Faculty of Environmental Management and Agriculture, University of Warmia and Mazury, pl. Łódzki 4, 10–957 Olsztyn, Poland, phone: +48 89 523 48 01, fax: +48 89 523 48 01, email: bezetka@uwm.edu.pl

emissions as well as the total quantity of industrial effluents. Pulp and paper wastewater can be treated by biological and chemical methods, but the applied techniques often fall short of increasingly stringent criteria, in particular those pertaining to organic compound removal efficiency. Further research is required to develop improved methods that best suit various types of waste materials so as to optimize wastewater treatment efficiency in observance of the local conditions.

The characteristic features of sludge, including post-coagulation sludge, are an important consideration in the process of optimizing wastewater treatment methods. For this reason, the aim of this study was also to determine the fractal dimension D [14] of aggregates produced by electrocoagulation. Fractal dimension is a source of valuable information about the aggregation mechanism. The fractal nature of aggregates has been studied in various experiments. In a study investigating aggregates formed during biological treatment of water and sewage, Da Hong Li and Ganczarzyk [15] noted that aggregates comprising active sludge particles and particles washed out of the filter bed have fractal properties. Various morphological characteristics of such aggregates could be determined by their fractal dimension. Aggregates formed in a coagulation model involving silica suspension and aluminum coagulants were investigated by Smoczynki and Wardzyska [16]. Their fractal dimension was closely correlated with the coagulants' chemical properties. The aggregates produced in the process of electro-flocculation were studied by Harif and Adin [17].

This study presents the results of the static electrocoagulation process using aluminum electrodes as a method for treating wastewater from the pulp and paper industry.

Materials and methods

Pulp and paper wastewater was obtained from the pulp and paper plant in Swiecie. The sampled wastewater was characterized by the following parameters: $\text{COD}_0 = 731 \text{ mg O}_2/\text{dm}^3$, turbidity – $1240 \text{ mg}/\text{dm}^3$, color – $240 \text{ mg}/\text{dm}^3$, suspended solids – $75 \text{ mg}/\text{dm}^3$.

The static system for wastewater electrocoagulation comprised a pair of aluminum electrodes measuring $16 \times 1 \times 0.1 \text{ cm}$, separated by a distance of 1 cm and immersed in a sewage tank. A self-designed control and supply system stabilized current intensity required for the analyzed process at $I_1 = 50 \text{ mA}$ and $I_2 = 100 \text{ mA}$. In this experiment, the density of current flowing through the electrodes was $\rho_1 = 3.125 \text{ mA}/\text{cm}^2$ and $\rho_2 = 6.25 \text{ mA}/\text{cm}^2$. A pH-meter and a burette for dosing 1 M HCl were installed in the sewage tank to maintain wastewater pH at 5.5–6.0 [18]. Samples were collected at equal time intervals, and after sedimentation, COD, turbidity, color and suspended solids were determined by spectrophotometry using a HACH DR 2000 spectrophotometer [19, 20]. Temperature and pH were measured with a HANNA HI 9025 pH meter.

The fractal dimension D of sludge aggregates produced in the treatment process was also determined during electrocoagulation. Fractal dimension values of the studied aggregates were measured 1 h after sedimentation. Fractal dimension was determined by the photographic method. The sedimentation path of aggregates formed by

electrocoagulation was photographed. The resulting images were used to determine the actual size (diameter) of flocs and their settling velocity, and to calculate the density “d”, of the examined aggregates. Fractal dimension was measured using Stokes’ law and the resulting correlation between an object’s density and its dimensions:

$$d \sim v / r^2 \quad (1)$$

where: d – density,
r – the object’s dimension,
v – settling velocity.

Because: $M(r) \sim r^D$ (2)

if D is the fractal dimension, M(r) – mass, then the following dependency can be obtained after a number of transformations:

$$\log d = (D - 3) \log r \quad (3)$$

A comparison between formula (3) and the general power law $y = ax^\alpha$ (a – amplitude, α – exponent) indicates that exponent α , ie the expression (D – 3) for formula 3, is equal to the logarithmic slope:

$$\log d \sim f(\log r) \quad (4)$$

The properties of 110 to 160 aggregates were measured for each process type. The collected data were used to map a logarithmic correlation (4) (Fig. 6 and 8) whose slope produced the value of D.

Results

The results of electrocoagulation treatment of wastewater with initial COD₀ of 731 mg O₂/dm³ in a static system are presented below. The process was conducted at two current density values of $\rho_1 = 3.125 \text{ mA/cm}^2$ and $\rho_2 = 6.25 \text{ mA/cm}^2$ and at different time intervals.

Figures 1 and 2 illustrate changes in the quantity of pollutants removed during electrocoagulation over time $t = 3600 \text{ s}$. Analytical samples were collected at equal time intervals of 900 s. The effects of wastewater treatment, both at $\rho_1 = 3.125 \text{ mA/cm}^2$ and $\rho_2 = 6.25 \text{ mA/cm}^2$, were visible already after 900 s of electrolysis, and they were magnified in the course of the process. A similar drop in COD values reaching a maximum of around 65 % was noted at both current density levels. At higher current density applied to the electrodes (ρ_2), the pollutants responsible for color and suspended solids were removed at a faster rate. Turbidity decreased at a slower rate, and its removal was maintained at a relatively low level of approximately 62 % throughout the process. Various forms of waste purified by electrocoagulation probably remained in the solution, contributing to an increase in turbidity values.

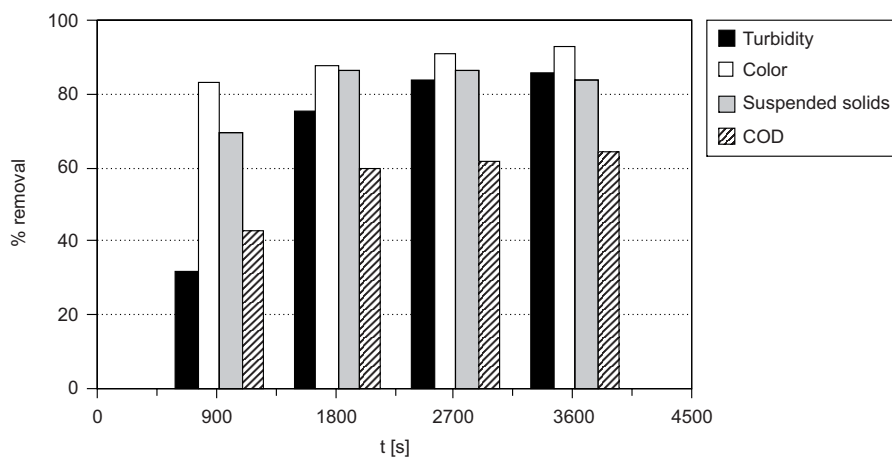

Fig. 1. Percentage removal of pollutants, described by selected parameters, during electrocoagulation performed at $\rho_1 = 3.125 \text{ mA/cm}^2$ and $t_{\text{max}} = 3600 \text{ s}$

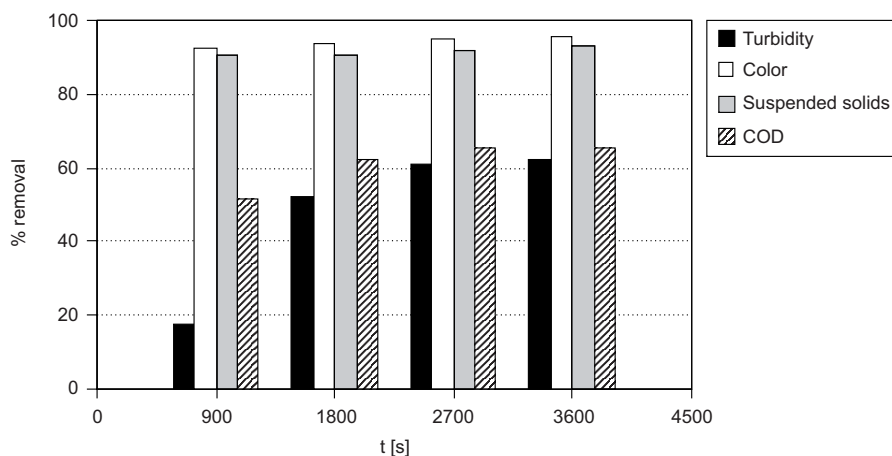

Fig. 2. Percentage removal of pollutants, described by selected parameters, during electrocoagulation performed $\rho_2 = 6.25 \text{ mA/cm}^2$ and $t_{\text{max}} = 3600 \text{ s}$

In view of prior research and the results of the referenced studies, the following diagram was proposed for processes taking place in the solution during electrocoagulation treatment involving aluminum electrodes [6, 9, 11]:



When Al^{3+} ions become “engaged” in the coagulation-flocculation process during wastewater treatment with the use of aluminum electrodes, the pH of the system

increases rapidly because only a part of the formed OH^- ions are transferred to the sludge:

For $x < 3$



After this stage, Al^{3+} ions formed on the anode effectively capture OH^- ions and precipitate them in the form of hardly soluble hydroxide sludge $\text{Al}(\text{OH})_3 \downarrow$. When the charge threshold is exceeded, the system is quickly destabilized, and an increase in Al^{3+} concentrations leads to the aggregation and flocculation of waste colloids, followed by sedimentation of the resulting sludge.

It cannot be ruled out that the time of sedimentation before sample collection was too short to support the separation of the resulting sludge, therefore turbidity removal values remained low. The increase in the degree of wastewater purification after the approximate time of $t = 1800$ s was insignificant enough for this value of t to be regarded as sufficient for the process, in particular at higher current density of $\rho_2 = 6.25$ mA/cm^2 . The above findings were taken into account in the next series of experiments whose results are presented below.

Figures 3 and 4 illustrate the results of electrocoagulation performed in the successive phase of parameter optimization, within a shorter time interval of 1620 s and at identical current density applied to electrodes ρ_1 and ρ_2 . In this group of experiments, two samples were collected for analysis during each process. In the first sample, the rate of COD removal exceeded 55 % already at half the time planned for the process. The application of higher current density ρ_2 (Fig. 4) resulted in high efficiency of turbidity removal and the complete elimination of suspended solids and color from the system. At the lower value of ρ_1 (Fig. 3), suspended solids were completely eliminated, turbidity removal reached 80 % and color removal – 90 %. The noted results indicate

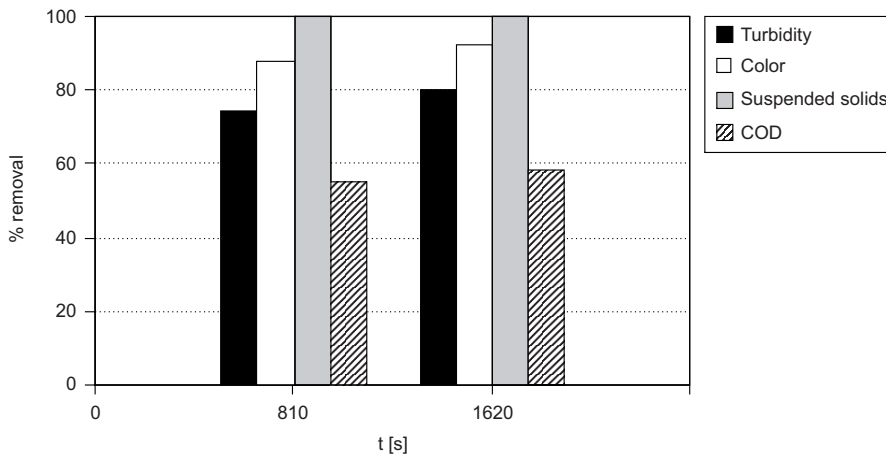

Fig. 3. Percentage removal of pollutants, described by selected parameters, during electrocoagulation performed at $\rho_1 = 3.125$ mA/cm^2 and $t_{\text{max}} = 1620$ s

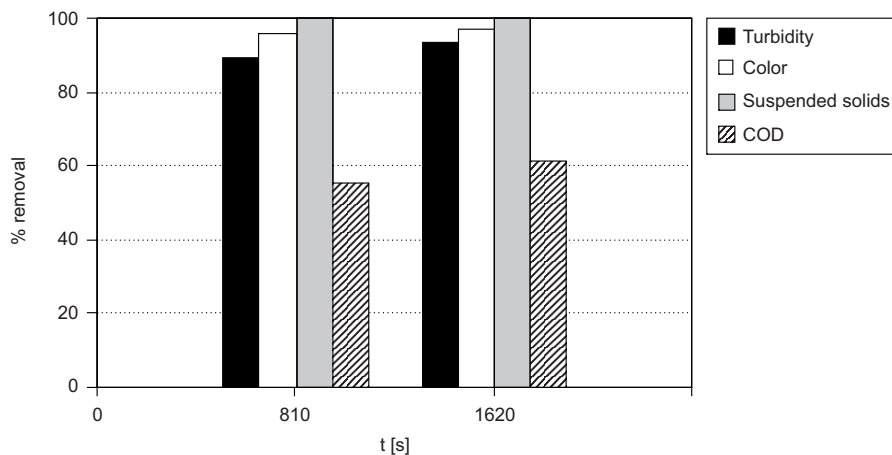

Fig. 4. Percentage removal of pollutants, described by selected parameters, during electrocoagulation performed at $\rho_2 = 6.25 \text{ mA/cm}^2$ and $t_{\text{max}} = 1620 \text{ s}$

that the studied process was more effective at a higher value of ρ_2 and that 1620 s was the optimal time for wastewater treatment.

The correlation between the value of electric charge Q supplied to the solution and purification effectiveness, measured in terms of COD removal, was also determined (Fig. 5). The value of Q was calculated using formula $Q = I \cdot t$ (Q – charge, I – current intensity) in terms of 1 dm^3 of wastewater. The above correlation indicates that an increase in electrical charge from 0 to around 650 C/dm^3 led to the continuous removal of more than 60 % COD from the treated wastewater. In excess of the above value, no further progress was observed in COD removal.

The results of analyses examining the aggregates produced during the electrocoagulation treatment of pulp and paper waste are presented in Tables 1 and 2.

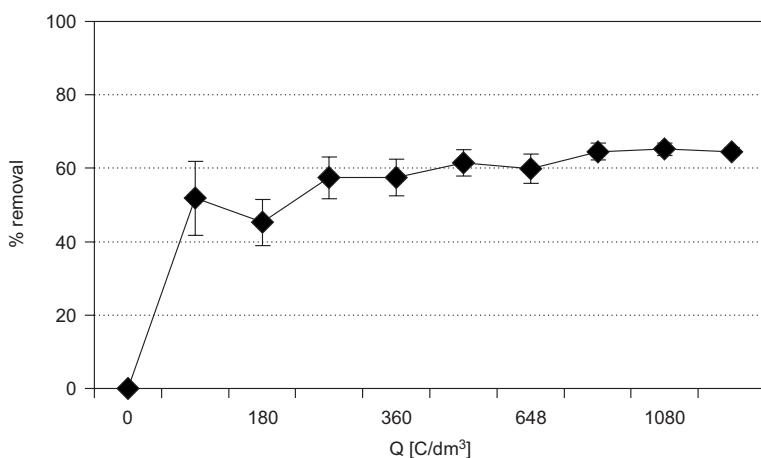

Fig. 5. COD removal subject to the charge flowing through the solution

Treatment effectiveness, expressed by changes in COD removal values, varied during the process. Sludge aggregates were sampled at various stages of treatment to determine their fractal dimension D .

Table 1

Fractal dimension of aggregates produced during the electrocoagulation of pulp and paper wastewater at $\rho_1 = 3.125 \text{ mA/cm}^2$

Electric charge flowing through the solution [C/dm ³]	% removal COD	Fractal dimension D
360	30.45	1.55
720	51.72	1.78
810	55.27	1.80
1620	58.14	1.90

Table 2

Fractal dimension of aggregates produced during the electrocoagulation of pulp and paper wastewater at $\rho_2 = 6.25 \text{ mA/cm}^2$

Electric charge flowing through the solution [C/dm ³]	% removal COD	Fractal dimension D
360	39.46	1.57
810	55.40	1.60
1620	61.56	1.85
3600	65.86	1.94

The fractal dimension D of the resulting aggregates was determined in the range of 1.55–1.90 for ρ_1 and 1.57–1.94 for ρ_2 . A proportional dependency was observed between the degree of wastewater purification and the value of D . The applied current density influenced the effectiveness of treatment (% COD removal) and, consequently, the value of D . The fractal dimension of aggregates in the treated wastewater is, to a varied extent, determined by the degree of sludge hydration. Lower values of D denote sludge characterized by a higher degree of hydration. With an increase in treatment effectiveness, the produced aggregates were marked by growing values of D . The above implies that the degree of sludge hydration decreased with an increase in the treatment effectiveness of liquid-phase waste.

Figures 6 and 8 present logarithmic dependencies $\lg d = f(\lg r)$ for selected aggregates based on which fractal dimension, D , was determined. The coefficients of determination for successive measurements were marked by symbol R^2 . The method of determining the fractal dimension based on dependency $\lg d = f(\lg r)$ proved to be statistically justified for all aggregates (the coefficient of determination for all processes exceeded 0.9), indicating that the produced aggregates are self-similar objects with fractal characteristics (Fig. 6 and 8).

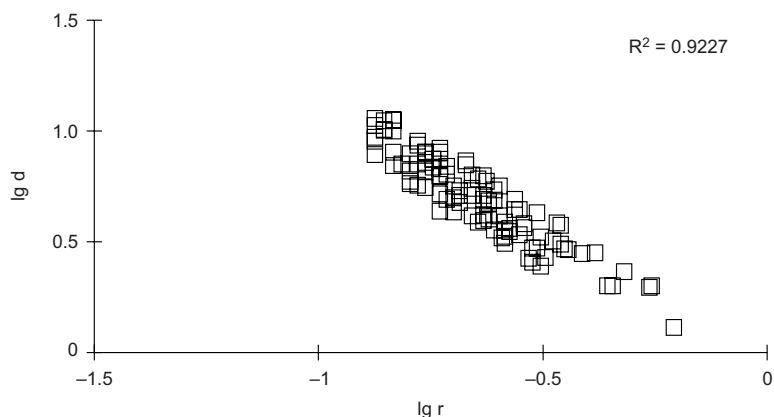

Fig. 6. Dependency $\lg d = f(\lg r)$ for $I = 100 \text{ mA}$, $\rho_2 = 6.25 \text{ mA/cm}^2$, COD rem. = 39.46 %, number of analyzed aggregates – 134, $D=1.57$

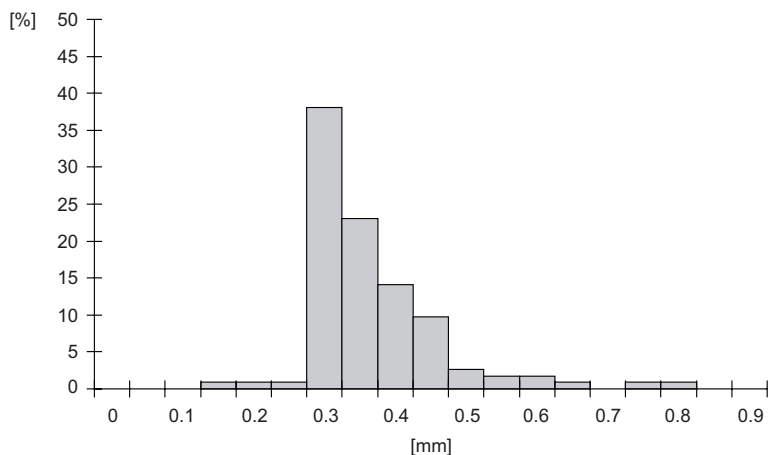

Fig. 7. Percentage share of aggregates in sludge subject to their actual size at $\rho_2 = 6.25 \text{ mA/cm}^2$, aggregate size and sedimentation rate: $r: 0.09\text{--}0.43 \text{ mm}$ $v: 0.09\text{--}0.39 \text{ mm/s}$, respectively

Figures 7 and 9 present the percentage share of aggregates in sludge subject to their actual size. Small-sized flocs with a diameter in the range of 0.06–0.93 mm were found to be the most predominant. A correlation was noted between fractal dimension and the percentage share of flocs of a given size. Sludge that contained a higher percentage of small flocs was characterized by higher values of D . A higher content of small flocs in post-coagulation sludge decreases sludge hydration and promotes the filling of sludge spaces with the solid phase. The resulting sludge comprised small aggregates, and it was also characterized by a low settling velocity, v , of individual flocs in the range of 0.07–0.65 mm/s, already during the sedimentation process.

The noted results once again [13] indicate that the fractal dimension of aggregates is an important tool during the evaluation of post-coagulation sludge. The fractal

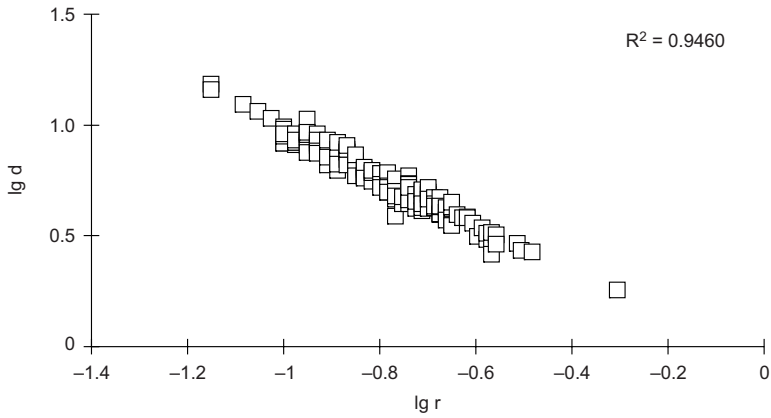

Fig. 8. Dependency $\lg d = f(\lg r)$ for $I = 50 \text{ mA}$, $\rho_1 = 3.125 \text{ mA/cm}^2$, COD rem. = 55.27 %, number of analyzed aggregates – 151, $D = -1.90$

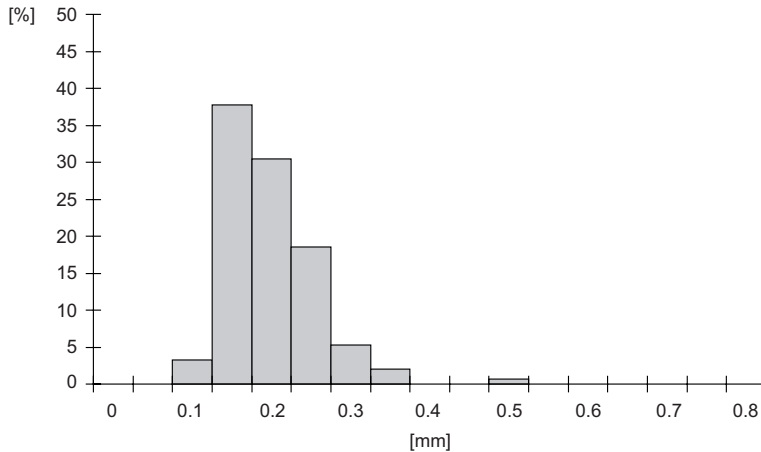

Fig. 9. Percentage share of aggregates in sludge subject to their actual size at $\rho_1 = 3.125 \text{ mA/cm}^2$, aggregate size and sedimentation rate: $r: 0.06\text{--}0.55 \text{ mm}$ $v: 0.07\text{--}0.44 \text{ mm/s}$, respectively

dimension of sludge is practically the only method supporting a quantitative description of irregularities, ie the degree of the studied objects' surface deformations, and the coefficient of determination (R^2) for dependency $\lg d \sim (\lg r)$ statistically proves the self-similarity of the studied aggregates.

Conclusions

1. The process of static electrocoagulation of pulp and paper wastewater with the involvement of aluminum electrodes was found to be an effective treatment method. It supported the removal of more than 60 % COD and a nearly complete elimination of color, turbidity and suspended solids from the treated wastewater.

2. The optimal results of wastewater treatment by static electrocoagulation were noted at $t = 1620$ s and current density of $\rho_2 = 6.25$ mA/cm².

3. The actual size of aggregates and their sedimentation rate was r : 0.06–0.93 mm and v : 0.07–0.65 mm/s, respectively, indicating that aggregates maintain the same morphological properties, and that every sub-unit has identical characteristics to the entire aggregate.

4. The parameters that affect waste treatment, ie electrolysis time, current density applied to the electrodes and pH, also determine the aggregation mechanism by influencing the aggregates' structure, size, shape and porosity and, consequently, the fractal dimension D of post-coagulation sludge.

5. Small-sized flocs had the highest share of post-coagulation sludge. This attribute supports the dewatering process because a higher contribution of small aggregates promotes the filling of sludge spaces with the solid phase.

References

- [1] Lin S.H. and Peng C.F.: *Continuous treatment of textile wastewater by combined coagulation, electrochemical oxidation and activated sludge*. Water Res. 1996, **30**(2), 587–592.
- [2] Ciardelli G. and Ranieri N.: *The treatment and reuse of wastewater in the textile industry by means of ozonation and electrocoagulation*. Water Res. 2001, **35**, 567–572.
- [3] Zongo I., Maiga A. H., Wethe J., Valentin G., Leclerc J.-P., Paternotte G. and Lapicque F.: *Electrocoagulation for the treatment of textile wastewaters with Al or Fe electrodes: Compared variations of COD levels, turbidity and absorbance*. J. Hazard. Mater. 2009, **169**, 70–76.
- [4] Jia J., Yang J., Liao J., Wang W.: *Treatment of dyeing wastewater with ACF electrodes*. Water Res. 1999, **33**, 881–884.
- [5] Szpyrkowicz L., Naumczyk J. and Zilio Grandi F.: *Application of electrochemical processes for tannery wastewater*. Toxicol. Environ. Chem. 1994, **44**, 189–202.
- [6] Smoczyński L. and Załęska-Chróst B.: *Electrocoagulation of pulp and paper wastewater in a recirculation system*. Polish J. Natur. Sci. 2002, **12**(3), 293–301.
- [7] Chen X., Chen G. and Yue P.L.: *Investigation on the electrolysis voltage of electrocoagulation*. Chem. Eng. Sci. 2002, **57**, 2449–2455.
- [8] Mollah M., Morkovsky P., Gomes J.A.G., Kesmez M., Parga J. and Cocke D.: *Fundamentals, present and future perspectives of electrocoagulation*. J. Hazard. Mater. 2004, **B 114**, 199–210.
- [9] Kobya M. and Delipinar S.: *Treatment of the baker's yeast wastewater by electrocoagulation*. J. Hazard. Mater. 2008, **154**, 1133–1140.
- [10] Chen L. Lai and Sheng H. Lin: *Treatment of chemical mechanical polishing wastewater by electrocoagulation: system performances and sludge settling characteristics*. Chemosphere 2004, **54**, 235–242.
- [11] Khemis M., Leclerc J.-P., Tanguy G., Valentin G. and Lapicque F.: *Treatment of industrial liquid wastes by electrocoagulation: Experimental investigations and an overall interpretation model*. Chem. Eng. Sci. 2006, **61**, 3602–3609.
- [12] Holt P., Barton G., Wark M. and Mitchell A.: *A quantitative comparison between chemical dosing and electrocoagulation*. Colloids Surf. 2002, **211**, 233–248.
- [13] Smoczyński L., Wardzyńska R. and Załęska-Chróst B.: *Elektrokoagulacja a koagulacja chemiczna. Porównanie metod oczyszczania ścieków celulozowo-papierniczych*. Acta Sci. Pol. Form. Circumiectus 2004, **3**(2), 3–14.
- [14] Mandelbrot B.B.: *The Fractal Geometry of Nature*. Freeman, New York 1983.
- [15] Da-Hong L. and Ganczarczyk J.: *Stroboscopic determination of settling velocity, size and porosity of activated sludge flocs*. Water Res. 1987, **21**(3), 257–262.
- [16] Smoczyński L. and Wardzyńska R.: *Study on macroscopic aggregation of silica suspensions and sewage*. J. Colloid Interf. Sci. 1996, **183**, 309–314.

- [17] Harif T. and Adin A.: *Characteristics of aggregates formed by electroflocculation of a colloidal suspension*. Water Res. 2007, **41**, 2951–2961.
- [18] Stumm W. and Morgan J.J.: *Aquatic Chemistry*. Willey Interscience, New York 1970.
- [19] Hermanowicz W., Dożańska W., Dojlido J., Koziorowski B. and Zerbe J.: *Fizyko-chemiczne badanie wody i ścieków*. Arkady, Warszawa 1999.
- [20] HACH DR /2000 Spectrophotometer Procedures Manual, Hach Company, Loveland, USA 1993.

OCZYSZCZANIE ŚCIEKÓW CELULOZOWO-PAPIERNICZYCH METODĄ ELEKTROKOAGULACJI W SYSTEMIE STATYCZNYM

Katedra Chemii, Wydział Kształtowania Środowiska i Rolnictwa
Uniwersytet Warmińsko-Mazurski w Olsztynie

Abstrakt: W niniejszej pracy przedstawiono wyniki elektrochemicznego oczyszczania ścieków celulozowo-papierniczych. Elektrolizę prowadzono w układzie statycznym, z użyciem elektrod glinowych. Badania prowadzono przy dwóch wartościach gęstości prądu na elektrodach $3,125 \text{ mA/cm}^2$ i $6,25 \text{ mA/cm}^2$. Po elektrokoagulacji i sedymentacji mierzono w roztworze ChZT, mętność, barwę oraz zawiesiny. Jednocześnie określono właściwości fraktalne otrzymanych agregatów-kłaczków osadu ściekowego i oznaczono ich rozmiary fraktalne. Badany proces elektrokoagulacji okazał się skuteczną metodą oczyszczania ścieków celulozowo-papierniczych. Badane agregaty-kłaczkki były obiektami „samopodobnymi”.

Słowa kluczowe: elektrokoagulacja, ścieki celulozowo-papiernicze, rozmiar fraktalny

Iwona ZAWIEJA¹, Paweł WOLSKI¹
and Lidia WOLNY¹

RECOVERING OF BIOGASS FROM WASTE DEPOSITED ON LANDFILLS

POZYSKIWANIE BIOGAZU Z ODPADÓW DEPONOWANYCH NA SKŁADOWISKACH

Abstract: The waste dump as the place, which is burdensome for the environment, can have disadvantageous influence on all its elements. It can affect directly: the air, the ground surface together with the soil, the surface and the underground waters and it can affect indirectly: the health of the population which lives in its surrounding and the animal world. In Poland the waste dumps (together with mines and water treatment plants) have dominant influence on the methane emission from so-called anthropogenic sources. The methane is the second gas, after carbon dioxide, which is responsible for the greenhouse effect. What is more, it is a valuable source of energy carrier, which is produced from the organic substances during the sophisticated process, as regards biochemistry, called oxygen-free stabilization. The content of gas in the vertical structure section of the deposit is not stable. The amount and the quality of waste dump gas depend mainly on the morphology and on the percentage content of the organic parts of the deposited wastes and on their humidity, on their effective concentration and on the insulating cover during the exploitation of the waste dump. According to the literature data, from 100 m³ of biogas there can be produced about 560–600 kWh of electric energy. The waste dump of the surface: 15 ha can give from 20 GWh up to 60 GWh of energy during a year if the year-long mass of the deposited wastes is about 180 000 Mg. The multilateral and multidimensional character of the renewable energy sources causes that they can have a significant influence both on the development of regional politics of the country, directly affecting the increase of the country energy safety level. They can also have an influence on the keeping to the emission limits which were imposed by European Union (EU), concerning, among others, the production of greenhouse gases. In the Kyoto report ratified in 1997 by Poland, all countries of EU are obliged to reduce the emission of greenhouse gases of 8 % up to 2012. In the article there have been discussed the issue concerning both the biogas energy potential and the management of biogas as well as there have been reviewed the legal acts concerning the usage of biogas which arises on the wastes dumps.

Keywords: biogas, methane, oxygen-free stabilization, waste dump, renewable energy sources (RES)

¹ Institute of Environmental Engineering, Faculty of Environmental Engineering and Protection, Czestochowa University of Technology, ul. Brzeźnicka 60a, 42–200 Czestochowa, Poland, phone: +48 34 325 73 34 ext. 64, email: izawieja@is.pcz.czest.pl

Legal requirements concerning the use of biogas as an alternative energy source

Biogas forming in the process of methane fermentation of biomass or the biodegradable part of waste is one of so-called biofuels. Biofuels provide an alternative to the commonly used fossil fuels. A decided turn in the European Union policy toward the wide utilization of *renewable energy sources* (RES) has been observed for a dozen or so years. The industry involved in the production of renewable energy is one of the most dynamically developing branches of the economy. In the EU legislation, this issue is regulated by the Directive 2001/77/EC on the promotion of electrical energy generated from renewable energy sources [1]. It requires Member States to implement legal measures intended to promote renewable energy sources, remove administrative barriers, and report on the progress of these activities. As the candidate for European Union membership, Poland was required to transpose the regulations of the Directive 2001/77/EC to the national legal system. The EU documents that determine the domestic policy for the development of energy generated from renewable energy sources, such as “The State’s ecological policy II” or “The strategy for the development of renewable power engineering” have set the quantitative targets and established the schedule of implementing renewable energy to the domestic electrical energy generation system.

The concept underlying of the oxygen-free stabilization process

Biogas is an energy-valuable fuel which is the product of a specific method of utilization of wastes of plant and animal origin. This method involves the oxygen-free (anaerobic) stabilization of waste. This is a biochemically complex process that proceeds in stages, in an appropriate temperature regime.

Waste disposed of on a landfill is a mix of organic and inorganic materials of different moisture content. If proper landfilling conditions are created, ie compacting followed by covering with a next layer of waste or backfill soil, then the period in which the action of oxygen and light takes place will be very short. This will create conditions for the occurrence of the process of oxygen-free decomposition of the waste. During the deposition of waste, five basic phases of chemical and biochemical processes can be distinguished, which lead to the formation of the fermentation gas, ie: the oxygen phase, the acetogenesis phase, the unstable methanogenesis phase, the stable methanogenesis phase, and the vanishing methanogenesis phase [2].

The energy potential of biogas

Methane is the simplest of the hydrocarbons. The methane molecule has the shape of a tetrahedron. It is a gas that relatively commonly occurs in nature [3]. Methane forms predominantly in the process of deoxidation (reduction) of carbon dioxide with hydrogen, according to the reaction $\text{CO}_2 + 3\text{H}_2 = \text{CH}_4 + \text{H}_2\text{O}$, and by metabolic

decomposition of acetic acid: $\text{CH}_3\text{COOH} = \text{CH}_4 + \text{CO}_2 + \text{energy}$. In the combustion of methane, carbon dioxide and water forms. This reaction is highly exothermic, therefore methane when mixed with air forms a dangerous explosive mixture with a proportion of the components of 5–15:100 (the lower explosive limit of 5, and the upper explosive limit of 15). By combusting 1 m³ of methane, approx. 1.6 kg of water in the form of vapour forms. For the combustion of 1 m³ of methane, approx. 10 m³ of air are needed [4]. The heat of combustion of methane is 13 264 kcal/kg, or 55.53 MJ/Mg, and its calorific value of is 11 954 kcal/kg, ie 50.05 MJ/Mg. The calorific value of biogas ranges from 18 to 24 MJ/m³ [5]. The oxygen-free decomposition can theoretically yield [6]:

- from 1 kg of carbohydrates: 456 dm³ CO₂ + 453 dm³ CH₄,
- from 1 kg of proteins: 516 dm³ CO₂ + 547 dm³ CH₄,
- from 1 kg of fats: 449 dm³ CO₂ + 1095 dm³ CH₄.

Knowing the chemical composition of waste, the amounts of methane and carbon dioxide that can be obtained from the unit mass of the waste can be calculated. The percentage content of methane in the landfill gas determines the method of biogas utilization. In the stable phase of methanogenesis, the methane content of gas is approx. 60 %, which, according to the PN-87/C-96001 standard, classifies it to sub-group 30 of natural gases [7]. Detailed requirements for the qualitative composition of biogas are standardized by the manufacturers of equipment using biogas. They refer primarily to the total contents of sulphur compounds, chlorine, fluorine and dust in the biogas. The most important factor determining the method of biogas utilization is the gas potential of landfills. The amount of generated landfill gas ranges from 60 to 180 m³/Mg of deposited waste.

As shown in Table 1, the level of concentration of main biogas components, ie methane and carbon dioxide, is very diverse, depending chiefly on the type and content of the component, the period of waste deposition, and the method of landfill use [6].

Table 1

Composition of biogas produced in the area of waste dump [8, 9]

Component	Range of occurring	Medium value
	[%]	
Methan, CH ₄	30–65	54
Carbon dioxide, CO ₂	30–50	40
Nitrogen, N ₂	5–40	10
Hydrogen (inflammable gas, H)	0–3 (1–3)	1
Oxygen, O ₂	0–5	1
Argon, Ar	0.04	0.1
Hydrogen sulfide, H ₂ S	0–0.01	0.003
Total sulphur	0–0.01	0.003
Total chlorine	0–0.005	0.002

Methane has many properties in common with natural gas, however the differences that exist between them are significant (Table 2). This entails the necessity of making

a considerable adjustment of the properties of biogas, if it is intended to be pumped into the regional natural gas grid (the same is true for filling steel cylinders intended for motor vehicles) [10].

Table 2

Differences between properties of biogas and natural gas distributed in the network

Component	Unit	Biogas	Natural gas
Methan, CH ₄	% mol	50–70	> 94
Carbon dioxide, CO ₂	% mol	25–45	≤ 2
Ammonia, NH ₃	mg/Nm ³	≤ 1000	lack
Hydrogen sulfide, H ₂ S	mg/Nm ³	≤ 2000	≤ 5
Oxygen, O ₂	% mol	≤ 2	≤ 0.5
Nitrogen, N ₂	% mol	≤ 8	≤ 5
Calorific value	kWh/Nm ³	6.8–8.4	10.7–12.8

Building of landfills

Landfills are civil engineering structures that are particularly noxious to the natural environment. Therefore, they must be properly designed and made in conformance to the *best available technologies* (BATs). According to the geotechnical classification of building structures, landfills belong to the third geotechnical category due to the environmental hazard that they are likely to cause. Each landfill is required to have a shield that will ensure it to be leakproof and protect the groundwater against contamination by effluent pollutants. The areas of landfills that do not have a sufficiently leakproof geological barrier in the ground must be additionally sealed [11].

The Regulation of the Minister of the Environment [12] on specific requirements for location, construction, operation and confinement, which should be met by particular landfill types, combines landfills for hazardous waste, non-hazardous waste and neutral wastes by stipulating for all of them the same requirements for making the mineral insulation shield. The landfill insulation profile specified in above-mentioned Regulation, corresponds to the minimum requirements of the European Union Directive [13].

A very important insulation layer in landfills is the mineral leakproof layer, ie the “geological barrier”, and the clay insulation layer made. The proper method of designing the seals of landfill base and slopes should allow for the geological and hydrogeological conditions, as well as other data on the waste and the landfill surface. Landfill surface sealing shields should be constructed as multi-layered and to be made from natural materials. The thickness of surface seals made (including the land reclamation and draining layer) can reach even 2 to 2.5 m, and depends on the land reclamation method. The cover layer should allow the vegetation growth. Figure 1 shows the surface layer profiles in the land reclamation of landfills, as recommended by the ITB (*Institute for Building Technology*) [14]. It should be noted that the profile does not include the synthetic layer, as in the municipal waste landfills it results in drying up of the landfill and halting gas production. The construction of the landfill surface

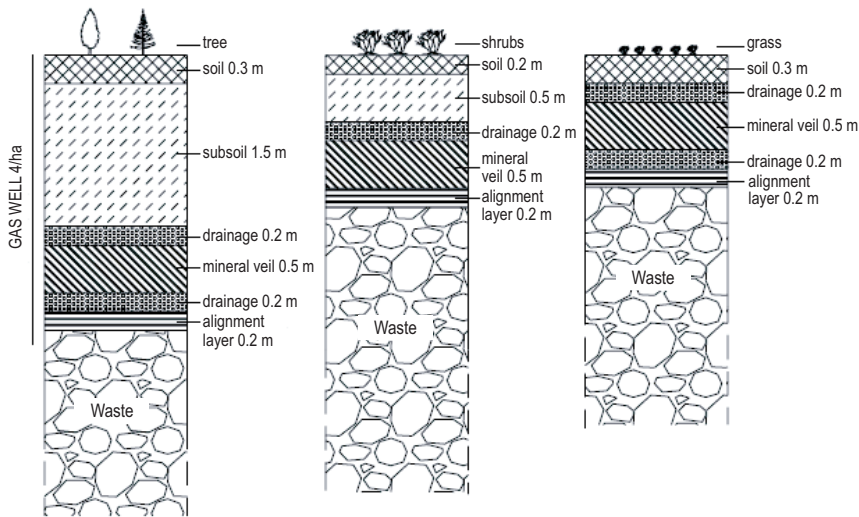

Fig. 1. Landfill surface sealing profiles, as recommended by the ITB [14]

sealing shield most often includes a levelling layer placed on the waste, capped by the following in the consecutive order: a gas draining layer, a mineral shield, a water draining layer, a filtering layer, a biological barrier, and a surface land reclamation layer [15].

Operation of landfills

The operation of a landfill is a very important element of its proper functioning. The aim of landfill operation complying with the regulations is to limit or minimize the emissions of pollutants during and after ending of landfill functioning. For landfill operation to be run properly, it is necessary to prepare an operation plan which should include all essential operation rules, information on landfill body formation, as well as the documentation of technical installations [16].

The operation of a landfill should ensure the minimization of the exposure of deposited waste surface to the elements, if it is necessary for reducing air contamination, including waste carry-over by wind.

In addition, it should prevent the accumulation of effluents and ensure that they undergo treatment to the extent that allow them to be received by the waste treatment plant or discharged to the surface water or to the ground, and also it should guarantee the geotechnical stability of the waste deposited [12]. Quarters shall be sectioned off on the landfill, each of the volume as specified in the building design of the landfill. The surface area of the quarters intended for the storage of hazardous waste should not exceed 2500 m². In the case of storing biodegradable waste, the operation of the next quarter may only be started upon obtaining the approval for the closure of the separated

part of the landfill. Non-hazardous and neutral wastes originated from waste neutralization processes, which are listed in the Catalogue of Wastes forming the Annex to the Regulation of the Minister of the Environment of 27th September, 2001, on the Catalogue of Wastes in sub-groups 19 01, 19 02, 19 03, 19 04 and 19 10, shall be stored in a separated quarter. In the process of closing a landfill or its part, land reclamation work shall be done in a manner that will prevent any harmful impact of the landfill on surface and underground waters and air, integrate the landfill area with the surroundings, and enable the observation of the landfill's influence on the environment [15]. Several technologically proven and economically viable systems of the recovery and utilization of biogas from selected municipal wastes of organic origin or from refuse deposited in the form of heaps on landfills are now functioning in Europe and in the world. The best developed technologies based on the oxygen-free fermentation process include the following: BTA (Germany), Dranko (Belgium), Rollweil (Germany), SWECO (Sweden) WABIO (Finland), Valorga (France) and others. The formation of gases in a waste bed is the result of the biochemical process that causes an increase in temperature and pressure. As a result of convective movements, these gases are released from the waste bed to the atmosphere, and in the case where the bed is not sufficiently sealed, the gases migrate also to ground base of the landfill. The current state of technology offers two basic methods of extracting gas from a landfill, ie the passive and the active degassing methods. Passive degassing is generally used in the operation of older landfills, but only when the gas systems are appropriately prepared for specific conditions. In new, well sealed landfills, active degassing is exclusively used. This is true in particular, where more than 10 thousand Mg (tonnes) of waste are disposed of on landfills, which is adequately compacted with heavy studded rolls, and when the individual layers of the waste being compacted are adequately backfilled with insulating soil. In so made beds, horizontal draining pipelines and vertical gas extraction shafts are gradually developed.

Poland's first implementations related to the use of landfill gas as a valuable energy source concerned plants generating solely electrical energy, with the power installed on particular landfills generally not exceeding 200 kW. There is currently a trend towards building larger plants (above 1 MW in power) or retrofitting existing ones to increase their power. Thermal energy produced in the co-generation process is most often used to meet the landfill operator's own needs, or is sold to municipal heat distribution services or other users. Moreover, after prior adjustment of its physicochemical parameters to those of natural gas, the biogas can be distributed to the municipal gas grid. The combustion of gas in gas engines coupled with generators contributes to the generation of mechanical energy that is used for driving compressors, pumps, generators and other mechanical equipment operated on the landfill site. In the case of having high methane content (on a level of 40–70 %), the biogas forming during the biological conversion of biomass is a particularly attractive energy medium for CHP (*Combined Heat and Power*) systems. The extraction of landfill gas from the landfill and its energy utilization prevents the free emission of the gas, which results in a reduction of the adverse environmental impact of the landfill.

The economics of a plant using landfill gas

Renewable energy sources are local sources that can increase the level of energy security in a national scale and provide appropriate standards in the protection of the atmosphere and the entire natural environment against pollution, as well as to create new jobs [17]. It has been established from model laboratory tests and practical measurements of biogas carried out on landfills that 1 Mg (tonne) of moist waste collected from households and businesses yields 80–160 m³ of landfill gas. Considering the average calorific value of biogas being equal to 4.5 kWh/m³ and the amount of recovered biogas being > 50 m³/h, it turns out that domestic refuse landfills constitute economically viable sources of renewable energy [18]. It is estimated that the energy utilization of landfill gas is economically viable for landfills with the total mass of deposited waste being at least $0.5 \cdot 10^6$ Mg. An analysis of landfills carried out by the Research & Development Centre for the Ecology of Towns (Ośrodek Badawczo-Rozwojowy Ekologii Miast, OBREM) in the aspect of economical viability of landfill gas utilization has found that such investment projects are cost-effective for landfills of an area above 3 ha and a minimum bed thickness of 5 m. Depending on the landfill size, the biogas utilization method, the biogas recovery technology used, the fuel properties of the biogas being recovered, and on the market prices of recovered heat or electricity, the incurred investment outlays give a return within 2 to 10 years [19]. It should be noted that landfill gas will be produced intensively for 10 to 15 years after the ending of landfill operation. This provides an unquestionable argument for the opinion that the energy utilization of landfill gas can bring about both environmental advantages, as well as measurable economic benefits.

Conclusions

The necessity of organic waste utilization is the main aim of biogas technological application, whereas the secondary aim is biogas production. Biogas is treated as accessory product of anaerobic stabilization of waste, being simultaneously valuable energetically fuel. Degassing of waste dump, in the ecological aspect, is equally important, as protection of its structure against migration of water leachates to the groundwater medium. Suitable system of waste dump degassing testifies its exploitational safety. According to the recommendations of the European Union, the waste dumps of total stored waste mass over 10 thousand Mg (ton) must own degassing instalation.

Acknowledgement

This work was financially supported by BW-401/202/07.

References

- [1] Directive 2001/77/EC of the European Parliament and of the Council of 27th September 2001 on the promotion of electricity produced from renewable energy sources in the internal electricity market.

- [2] Kempa E.S.: Gospodarka odpadami na wysypiskach, Wyd. Arka Konsorcjum s.c., Poznań 1993.
- [3] Metan, Encyklopedia WIEM, <http://portalwiedzy.onet.pl>.
- [4] Matuzik M.: *Biogazownie w zachodniopomorskim – patent na paliwo i lepszy zapach*. Energia Gigawat 2005, <http://www.gigawat.info/archiwum/index.php/article/articleview/590/1/55/index.html>
- [5] Rosik-Dulewska Cz.: Podstawy gospodarki odpadami, Wyd. Nauk. PWN, Warszawa 2006.
- [6] Skorek J. and Kalina J.: Gazowe układy kogeneracyjne. WNT, Warszawa 2005.
- [7] Czurejno M.: *Biogaz środowiskowy, jako źródło alternatywnej energii*. Energet. Ekol. 2006, **10**, 777–781.
- [8] Willmunsen H.C. *Energy recovery from landfill gas in Denmark and worldwide*. Międzynarodowe Sympozjum, Utilization of landfill gas for energy production. Lithuanian Energy Institute, Print of Kaunas University of Technology, Kaunas, Lithuania 2001.
- [9] Manczarski P.: Systemy odgazowani składowisk odpadów komunalnych – zagadnienia procesowe i technologiczne, www.drewnozamiastbenzyny.pl
- [10] Kotowski W.: *Wylapać metan*. Energia Gigawat 2006, http://www.ekoenergia.pl/index.php?id_art=404&cms=108&plik=Biogaz_-_biogazownie.html.
- [11] Wysokiński L.: *Przegląd problemów związanych ze składowaniem odpadów*. Mater. Budowl. 2006, **11**(411), 34–36.
- [12] Rozporządzenie Ministra Środowiska z dnia 24 marca 2003 r. W sprawie szczegółowych wymagań dotyczących lokalizacji, budowy, eksploatacji i zamknięcia, jakim powinny odpowiadać poszczególne typy składowisk odpadów (DzU 2003, nr 61, poz. 549).
- [13] Zawisza M.: *Geosyntezyki na składowiskach odpadów komunalnych*. Mater. Budowl. 2006, **11**(411), 45.
- [14] Wysokiński L.: *Projektowanie i wykonywanie przesłon izolacyjnych z materiałów mineralnych na składowiskach odpadów komunalnych*. Instrukcja ITB nr 337. Wyd. ITB, Warszawa 1996.
- [15] Projektowanie i budowa nowoczesnego składowiska odpadów, Internet, <http://odpady.org.pl/plugins/content/content.php?content.1665.2>
- [16] Bilitewski B., Hardtle G. and Marek K.: Podręcznik gospodarki odpadami. Wyd. Seidel-Krzywecki, Warszawa 2003.
- [17] Wiśniewski G.: Odnawialne źródła energii jako element rozwoju lokalnego, Przewodnik dla samorządowców terytorialnych i inwestorów. Wyd. EC BREC/IMBER, Warszawa 2003.
- [18] Stępnik S.: *Ustalenie potencjału gazowego, metody określania prognoz wysypisk komunalnych*, Przegl. Energet. 2006, **4**, 33–35.
- [19] Czurejno M.: *Energetyczne wykorzystanie gazu składowiskowego*. Ekonatura 2005, **3**(16), 20–22.

POZYSKIWANIE BIOGAZU Z ODPADÓW DEPONOWANYCH NA SKŁADOWISKACH

Instytut Inżynierii Środowiska, Wydział Inżynierii Środowiska
Politechnika Częstochowska

Abstrakt: Składowisko jako obiekt uciążliwy dla środowiska może oddziaływać niekorzystnie na wszystkie jego elementy, bezpośrednio na powietrze, powierzchnię ziemi wraz z glebą, wody powierzchniowe i podziemne oraz pośrednio na zdrowie ludności zamieszkałej w jego otoczeniu, jak również świat zwierząt. W Polsce składowiska odpadów (wraz z kopalniami i oczyszczalniami ścieków) mają dominujący wpływ na emisję metanu z tzw. źródeł antropogennych. Metan jest drugim po ditlenku węgla gazem odpowiedzialnym za zjawisko cieplarniane. Ponadto jest wartościowym nośnikiem energii, wytwarzanym z substancji organicznych podczas złożonego pod względem biochemicznym procesu, jakim jest stabilizacja beztlenowa. Skład biogazu w pionowym przekroju złoża nie jest stały. Plość i jakość gazu składowiskowego zależy głównie od morfologii i procentowej zawartości części organicznych deponowanych odpadów oraz od ich wilgotności, efektywnego zagęszczenia, a także przykrycia izolacyjnego w trakcie eksploatacji składowiska. Jak podają dane literaturowe, ze 100 m³ biogazu można wyprodukować około 560–600 kWh energii elektrycznej. Ze składowiska o powierzchni około 15 ha można uzyskać od 20 do 60 GWh energii w ciągu roku, jeżeli roczna masa składowanych odpadów to około 180 tys. Mg (ton). Poprzez swoją wielostronność i wielowymiarowość odnawialne źródła energii mogą znacząco przyczynić się zarówno do rozwoju polityki regionalnej kraju, wpływając bezpośrednio na zwiększenie poziomu bezpieczeństwa energetycznego, jak również dotrzymanie wprowadzonych przez Unię Europejską (UE) limitów emisyjnych, dotyczących m.in.

wytwarzania gazów cieplarnianych. W ratyfikowanym przez Polskę protokole z Kioto z 1997 r., kraje UE zobowiązały się zredukować do roku 2012 emisję gazów cieplarnianych o 8 %. W artykule podjęto problematykę dotyczącą zarówno potencjału energetycznego biogazu, instalacji służących do ujmowania biogazu oraz jego zagospodarowania, jak również dokonano przeglądu aktów prawnych dotyczących wykorzystania biogazu powstającego na składowiskach odpadów

Słowa kluczowe: biogaz, metan, stabilizacja beztlenowa, składowisko odpadów, odnawialne źródła energii (OZE)

Anna ZWOŹDZIAK¹, Izabela SÓWKA¹, Maria SKRĘTOWICZ¹,
Anna WOROBIEC², Alicja NYCH¹, Jerzy ZWOŹDZIAK¹
and Rene VAN GRIEKEN²

PM₁₀, PM_{2.5} AND PM_{1.0} INDOOR AND OUTDOOR CONCENTRATIONS AND CHEMICAL COMPOSITION IN SCHOOL ENVIRONMENT

STĘŻENIA ORAZ SKŁAD CHEMICZNY PYŁU PM_{1.0}, PM_{2.5} ORAZ PM₁₀ W POWIETRZU WEWNĘTRZNYM I ZEWNĘTRZNYM SZKOŁY

Abstract: Simultaneous daily indoor and outdoor measurements of PM_{1.0}, PM_{2.5}, PM₁₀ have been conducted during winter season of 2009/2010 in the secondary school in Wrocław, Poland. Aerosol samples were analysed for mass concentrations and elemental composition. The factor analysis was applied to identify possible emission sources of the PM_{1.0} fraction. Mean daily PM₁₀ concentrations was 81 µg/m³ indoors and 54 µg/m³ outdoors. The corresponding means for PM_{2.5} and PM_{1.0} were 62 and 22 µg/m³ indoors and 46 and 24 µg/m³ outdoors. There were reported 90 % of days with daily mean exceeding the WHO AQG for PM_{2.5} – 25 µg/m³. In many cases the I/O ratio was higher than 1.0, what means that there are some particles sources inside the school building, particularly for the fractions PM₁₀ and PM_{2.5}. The most abundant elements in the PM_{1.0} fraction were S, Cl and K. Zn and Pb were the dominant heavy metals. Combustion processes contributed to high concentrations of K, S, As, Cl and vehicular emission to Cu, Pb and Zn.

Keywords: PM_{1.0}, PM_{2.5}, PM₁₀ indoor-outdoor particles, elemental composition

Many epidemiological studies allowed to prove the influence of air pollution on human health [1, 2]. The important factors that may affect human health are: the type of air pollutant, its exposure level and personal sensibility (the highest for children and old people). Among others, trace metals associated with aerosol particles with the diameter below 10 µm (PM₁₀), 2.5 µm (PM_{2.5}) and 1 µm (PM_{1.0}) may contribute to particulate toxicity related to an increased risk of respiratory and/or cardiovascular diseases [3, 4].

¹ Faculty of Environmental Engineering, Wrocław University of Technology, ul. Wybrzeże Wyspiańskiego 27, 50-370 Wrocław, Poland, phone: +48 71 320 25 00, fax: +48 71 320 35 99, email: anna.zwozdziak@pwr.wroc.pl

² Faculty of Science, University of Antwerp, Universiteitsplein 1, 2610 Antwerp, Belgium, phone: +32 3 265 41 11, fax: +32 3 265 20 04, email: anna.worobiec@ua.ac.be

Much efforts have been made in Europe in improving ambient air quality, but only recently has the international scientific community worried about the indoor air contamination. Indoor levels of many pollutants may be many times higher than outdoor ones [5–7]. Schoolchildren spend as much as 30 percent of their time at school, thus indoor air quality problems in schools are a significant public health concern. Published results regarding *particulate matter* PM₁₀, PM_{2.5} and PM_{1.0} and their chemical composition in school-environment are, at least to the knowledge of the authors, rather scarce in Poland or even they do not exist.

We describe the results of a pilot study evaluating indoor and outdoor PM₁₀, PM_{2.5} and PM_{1.0} concentrations in naturally ventilated school environment in Wrocław. The aerosol samples were analysed for their mass concentrations and elemental composition. The primary purposes of this study were to investigate: (1) differences in the PM₁₀, PM_{2.5} and PM_{1.0} mass concentrations in indoor and outdoor air; (2) elemental composition of PM_{1.0} and the *indoor-to-outdoor* ratios (I/O), and (3) the origin of indoor and outdoor PM_{1.0} particles.

Materials and methods

Simultaneous indoor (in the school hall) and outdoor (at the school roof) PM₁₀, PM_{2.5} and PM_{1.0} concentration measurements were conducted in Secondary School No. 13 located in the centre of Wrocław. The measurements were performed on a daily basis (24 h or 2 × 12 h, for one week in December 2009 and in January 2010) with the use of Harvard cascade impactors (MS&T Area Samplers, Air Diagnostics and Engineering, Inc., Harrison, ME, USA). The pumps were set at an airflow of 23 dm³/min for PM_{1.0}, and 10 dm³/min for PM_{2.5} and PM₁₀. The particles were collected onto 37 mm diameter Teflon membrane filters (PALLFLEX, TK15-G3M). All filters were pre- and post-conditioned in a clean room with environmentally controlled temperature and humidity prior to weighing. Weighing was carried out with an electronic microbalance (Santorius 000 V001).

The bulk elemental composition was analysed with an Epsilon-5 energy dispersive XRF instrument (PANalytical, Almelo, the Netherlands). The details of sampling and the accuracy of analytical methods is given in [8]. In total, 20 elements were determined (Al, Si, S, Cl, K, Ca, Ti, V, Cr, Mn, Fe, Ni, Cu, Zn, As, Se, Sr, Cd, Sb and Pb). Almost all elements were detected in each sample, except for Se, Cd, Al which were not detected in 72, 50 and 52 % of the samples, respectively. Sb was not detected at all.

Results and discussion

A comparison of mean concentrations with standard deviations and the ranges of indoor particulate matter in 3 sizes including PM₁₀, PM_{2.5} and PM_{1.0} for both sampling campaigns is shown in Fig. 1. PM₁₀ daily concentrations ranged between 21 and 113 µg/m³ indoors (mean: 81 µg/m³) and between 26 to 87 µg/m³ outdoors (mean:

54 $\mu\text{g}/\text{m}^3$). The respective PM2.5 and PM1.0 daily concentrations varied between 18 and 91, and from 13 to 32 $\mu\text{g}/\text{m}^3$ indoors (means: 62 and 22 $\mu\text{g}/\text{m}^3$), and from 24 to 72 and 15 to 41 $\mu\text{g}/\text{m}^3$ outdoors (means: 46 and 24 $\mu\text{g}/\text{m}^3$). What is very important that mass concentrations exhibited significant variability. This effect was more pronounced in the PM10 and PM2.5 fractions. 12 h PM10 and PM2.5 indoor concentrations, when available, showed that the values decreased during the night time and on weekends. This indicates that the absence of people inside the school after classes greatly influenced the indoor concentration levels. In the case of PM1.0 concentrations, the situation was not so clear.

The ratio I/O allows to assess whether there are different sources of particulate matter or not. Daily I/O concentration ratios for PM10 varied between 0.8 and 2.5 (mean: 1.5), while for PM2.5 and PM1.0 the I/O ranges were estimated equal to 0.7–1.6 and 0.7 to 1.2, respectively (means: 1.3 and 0.9). In many cases this ratio was higher than 1.0, what means that there are some particle sources inside the school building, particularly for the fractions PM10 and PM2.5. Their existence was confirmed by the correlation analysis. Except for the fraction PM1.0 ($\text{PM1.0}_{\text{in}} = 0.94 \text{ PM1.0}_{\text{out}}$, $R^2 = 0.87$), there were very weak correlations ($R^2 < 0.5$) between concentrations inside and outside the building. This indicates that indoor concentrations of PM10 and PM2.5 were independent on the corresponding outdoor ones. Only the finest fractions could easily penetrate inside the school. Therefore, PM1.0 mass concentrations in indoor and outdoor air and their daily fluctuations were relatively on the same levels.

The mean I/O ratios above 1.0, for both PM10 and PM2.5, were found in many other studies conducted in schools, for instance in London [5], Detroit [6] or Athens [7].

Adverse health effects of particulate matter are mostly attributed to finer particulate matter, thus this fraction was studied more extensively in this work. Table 1 shows indoor mean concentrations of individual elements in the fraction PM1.0 and the *indoor/outdoor* (I/O) concentration ratios. Analysis of the data showed that there were large variations in the range of concentrations observed for each of the elements. The most abundant elements were S, Cl and K. Zn and Pb were the dominant heavy metals. Particularly noteworthy is the presence of significant amounts of Pb, Zn, As, Cu, which can be a serious danger for human health [9].

Much higher indoor concentrations than outdoor ones were observed for crustal elements (Si, Ca, Ti, Fe, Mn). As considered earlier, the reason for this high I/O ratio was probably resuspension of settled fine mineral dust during cleaning (sweeping) and children movement. Many studies suggest that human activity contributes mainly to resuspension of larger particles, that was confirmed in our study for PM10, and to lesser degree for PM2.5, but also the highest I/O ratio values were found for crustal element in the PM1.0 fraction. However, these elements contributed only to about 4 % of the elements mass analyzed in the indoor PM1.0 fraction. Fine particles could remain suspended in air with relatively long time and due to poor ventilation during winter, this process could lead to their accumulation. The I/O concentration ratios for other elements, except for Cl, were at the comparable levels but the values were also above 1.0. Nevertheless, these increases in values for indoor air were small compared with the ones for Si, Ca, Ti and Mn.

Table 1

Indoor mean concentrations of individual elements in the fraction PM1.0
and the indoor/outdoor (I/O) concentration ratios

Element	Mean	Minimum	Maximum	I/O ratio
Si	114.5	17.6	602.4	3.7
K	415.4	193.9	1338	1.1
Ca	33.7	10.0	70.5	6.7
Ti	4.9	0.4	56.9	3.8
Fe	142.4	12.5	1882	2.0
Cr	1.7	< DL*	4.0	1.3
Ni	1.02	0.30	1.63	1.5
Mn	27.8	4.2	319.5	2.2
Cu	23.4	4.2	40.3	1.3
Zn	169.6	50.1	385.5	1.1
As	2.8	< DL	7.4	1.0
Pb	52.4	25.3	99.0	1.1
S	957.3	407.1	1997	1.2
Cl	266.8	43.5	1079	0.3
Cd	0.78	< DL	4.65	1.3

* < DL – below detection limit.

Simultaneous measurements of PM1.0 mass concentrations at this school showed that the differences between indoor and outdoor air were only within a few percentage range (Fig. 1), and the concentrations were strongly correlated. In the school, no fine

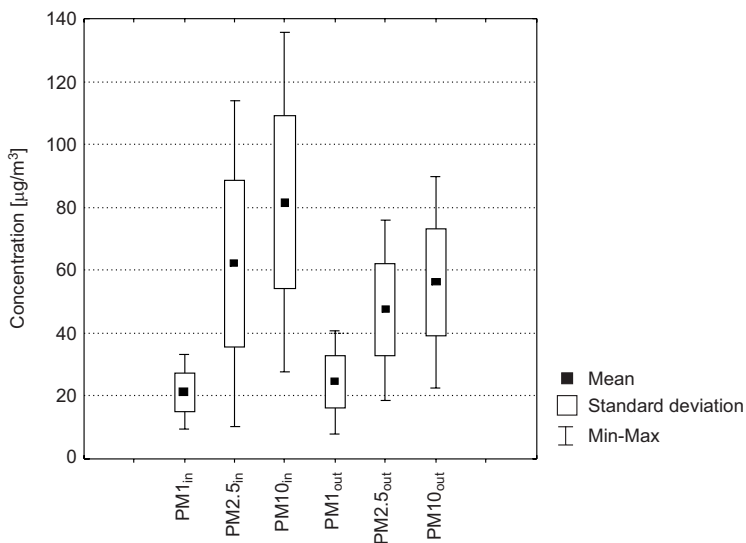

Fig. 1. Mean concentrations, standard deviation and the ranges of indoor (in) and outdoor (out) particulate matter for the fractions PM10, PM2.5 and PM1.0 (cold season, naturally ventilated school)

particle sources such as wood and coal burning and smoking are present. This suggests that the outdoor air is the main contributor to the indoor PM1.0 mass concentrations. As noted earlier some impact of resuspension of mineral dust should be also considered.

In order to estimate the impact of different emission sources on ambient PM1.0 mass concentrations, factor analysis was applied to identify possible emission sources of air particles. Trace elements were used as the markers for the above assessment. Table 2 shows factor loadings from factor analysis for three components. The commonalities for individual elements ranged from 0.76 for As to 0.99 for remaining elements considered. This indicates that three components are quite satisfactory explaining 84 % of the total variance.

Table 2

Factor loadings of individual elements for the PM1.0 fraction (outdoors)

Element	Crustal sources	Coal/wood combustion	Vehicle emission	Commonality
K	0.17	0.84	0.33	0.98
Ca	0.86	0.02	0.08	0.97
Ti	0.99	0.02	0.08	0.99
Fe	0.96	0.13	0.05	0.99
Mn	0.89	0.03	0.41	0.99
Cu	0.06	0.04	0.96	0.97
Zn	0.68	0.36	0.56	0.99
As	0.03	0.81	0.01	0.76
Pb	0.34	0.44	0.80	0.99
S	0.03	0.74	0.29	0.95
Cl	0.08	0.84	0.18	0.85
% variance	44	25	14	84

The first factor that explains 44 % of the variance has high loadings of Si, Ca, Ti, Fe and Mn. It is anticipated that the contribution is from the street dust – soil. However, Ca and Si, which are indicators of crustal matter, were detected at relatively low levels.

Factor 2 includes high factor loadings for K, S, As and Cl that are identified as markers for typical combustion sources. S and As are typical markers for coal combustion in the fine size range [10]. S, K and Cl for wood burning or generally biomass burning [11, 12]. These elements represent above 90 % of the elements mass analyzed in the outdoor PM1.0 fraction.

Factor 3 associated mainly with Cu and Pb (weaker with Zn) usually represents an industrial emission source. However, in our case, in the centre of Wroclaw, it is likely that these metals originated from traffic. Studies of some roadway dust particles have shown the presence in small size particles of Pb along with other metals such as Br, Zn and Cu [13]. Cu comes mainly from brake lining wear, Pb from exhaust fumes and Zn from tyre wear and brake lining wear.

Conclusion

Our results revealed that indoor concentrations of PM_{2.5} and PM₁₀ were higher than outdoor values for the most sampling days. In the presence of high variability of indoor PM₁₀ concentrations and a weak correlation with PM_{1.0} concentrations, the contribution of PM_{1.0} in PM₁₀ varied significantly, from 11 to 59 %. The contribution of PM_{2.5} in PM₁₀ equalled about 78 % for indoor air and 85 % for outdoor air. Daily PM₁₀ concentrations often exceeded the EU limit values for atmospheric air (50 µg/m³).

Concentrations of PM_{1.0} in the school hall and in outdoor air were relatively in the same levels. A high correlation between PM_{1.0} concentrations inside and outside the building was recorded.

There are some influences on indoor air quality, such as cleaning (sweeping), children movement that cause higher turbulence and stop dust sedimentation. It was proved by higher concentrations of PM₁₀ and PM_{2.5} during the day than the night time and on weekends.

It was observed that a significant amount of heavy metals associated with PM_{1.0} fraction, both in indoor and outdoor air, is of anthropogenic origin (combustion processes and vehicular emission). Combustion processes were the most important sources that contributed to high concentrations of As, and vehicular emission to Zn, Pb and Cu.

There is a need to control the particulate matter indoor concentrations. Suitable regulations and standards for indoor air quality should be created, as the finest aerosols can be more dangerous for human's health than the coarse ones.

Acknowledgement

Presented work was done in the frame of the Project No. N N304 067937: "Identification of air quality impact on the school children's respiratory function".

References

- [1] WHO (World Health Organization) Europe. Air quality guidelines for particulate matter, ozone, nitrogen dioxide and sulfur dioxide. Global update 2005. Geneva 2006.
- [2] WHO (World Health Organization) Europe. Health risk of PM from long range transboundary air pollution, Copenhagen 2006.
- [3] Timonen, K.L., Pekkanen J., Tiittanen P. and Salonen R.O.: *Occup. Environ. Med.* 2002, **59**, 129–134.
- [4] Moshhammer H., Hutter H.P., Hauck H. and Neuberger M.: *Eur. Respir. J.* 2006, **27**, 1138–1143.
- [5] Wheeler A.J., Williams I., Beaumont R.A. and Hamilton R.S.: *Environ. Monit. Assess.* 2000, **65**, 69–77.
- [6] Yip F.Y., Keeler G.J., Dvonch J.T., Robins T.G., Parker E.A., Israel B.A. and Brakefield-Caldwell W.: *Atmos. Environ.* 2004, **38**, 5227–5236.
- [7] Diapouli E., Chaloulakou A. and Spyrellis N.: *Indoor Built Environ.* 2007, **16**, 55–61.
- [8] Horemans B., Worobiec A., Buczynska A., Van Meel K. and Van Grieken R.: *J. Environ. Monit.* 2008, **10**, 867–876.
- [9] Chapman R.S., Watkinson W.P., Dreher K.L. and Costa D.L.: *Environ. Toxicol. Pharmacol.* 1997, **4**, 331–338.
- [10] Cao L., Tian W., Ni B., Zhang Y. and Wang P.: *Atmos. Environ.* 2002, **36**, 1951–1956.
- [11] Song X.H., Pollissar A.V. and Hopke P.K.: *Atmos. Environ.* 2001, **35**, 5277–5286.
- [12] Cheng Z.L., Lam K.S., Chan L.Y., Wang T. and Cheng K.K.: *Atmos. Environ.* 2000, **34**, 2777–2783.
- [13] Dongarra G., Sabatino G., Triscarib M. and Varricaa D.: *J. Environ. Monit.* 2003, **5**, 766–773.

**STĘŻENIA ORAZ SKŁAD CHEMICZNY PYŁU PM1.0, PM2.5 ORAZ PM10
W POWIETRZU WEWNĘTRZNYM I ZEWNĘTRZNYM SZKOŁY**¹ Wydział Inżynierii Środowiska, Politechnika Wroclawska² Wydział Nauk Przyrodniczych, Uniwersytet w Antwerpii

Abstrakt: Jednoczesne pomiary stężeń pyłu PM1.0, PM2.5, PM10 w powietrzu wewnętrznym i zewnętrznym zostały przeprowadzone w szkole średniej we Wrocławiu w sezonie zimowym 2009/2010 roku. Pobrane próbki aerozolu analizowano pod względem wysokości stężenia masowego oraz składu pierwiastkowego. Analizę czynnikową wykorzystano do oceny źródeł pochodzenia cząstek frakcji PM1.0. W powietrzu wewnętrznym średnie dobowe stężenie PM10 wynosiło 81 $\mu\text{g}/\text{m}^3$, a zewnętrznym 54 $\mu\text{g}/\text{m}^3$. Odpowiednie średnie dla PM2.5 i PM1.0 wynosiły 62 i 22 $\mu\text{g}/\text{m}^3$ wewnątrz i 46 i 24 $\mu\text{g}/\text{m}^3$ na zewnątrz budynku. Na podstawie przeprowadzonych pomiarów odnotowano 90 % dni ze średnim dobowym stężeniem frakcji PM2.5 powyżej wartości zalecanej w wytycznych Światowej Organizacji Zdrowia, tj. 25 $\mu\text{g}/\text{m}^3$. W wielu przypadkach stosunek stężeń w powietrzu wewnętrznym (I) do stężeń w powietrzu zewnętrznym (O), tj. I/O, był większy od 1.0, co oznaczało istnienie źródeł pyłów wewnątrz budynku, a dotyczyło do przede wszystkim frakcji PM10 i PM2.5. We frakcji PM1.0 w największych koncentracjach pojawiały się S, Cl i K, a wśród metali ciężkich Zn i Pb. Procesy spalania miały największy udział w stężeniach K, S, As i Cl, natomiast motoryzacja w przypadku stężeń Cu, Pb i Zn.

Słowa kluczowe: PM1.0, PM2.5, PM10, powietrze wewnętrzne i zewnętrzne, skład elementarny

Agnieszka BARAN¹, Marek TARNAWSKI²
and Czesława JASIEWICZ¹

ASSESSMENT OF THE CONTENT AND SOLUBILITY OF HEAVY METALS IN BOTTOM SEDIMENTS OF THE CHANCZA RESERVOIR

OCENA ZAWARTOŚCI I ROZPUSZCZALNOŚCI METALI CIĘŻKICH W OSADACH DENNYCH ZBIORNIKA CHAŃCZA

Abstract: The investigations aimed at an assessment of the content and solubility of heavy metals in bottom sediments of the Chancza water reservoir. The bottom sediments were sampled from previously identified cross-sections characteristic for individual reservoir zones: inlet – section 8; middle – section 5; the dam-side – section 1. Bottom sediment was sampled along each section, in three points in the vicinity of the right and left bank and in the middle of the cross-section. In order to average the collected material, the samples were collected from 6 points within the radius of 5–8 meters from the appointed location. The sediment was sampled using Ekman's sampler. Total contents of heavy metals (Zn, Cu, Ni, Cr, Pb and Cd) and their forms soluble in 1 mol HCl, in 0.01 mol CaCl₂ · dm⁻³ and in distilled water were assessed in air-dried samples of the sediments. Metal concentrations in the obtained solutions were assessed using ICP-AES method. The highest concentrations of heavy metals were assessed in the sediment samples collected on the reservoir inlet, then at the dam-side, whereas the lowest amounts were found in the samples from the middle part of the reservoir. Solubility of heavy metals depended on the extracting solution used and their total concentrations in the analyzed sediment. The best average solubility in 1 mol HCl · dm⁻³ characterized Pb, followed by Cd > Zn > Cu > Ni > Cr, whereas in 0.01 mol CaCl₂ · dm⁻³: Cu > Pb > Ni > Cr > Zn. Strong linear correlations were demonstrated between individual pairs of heavy metals in bottom deposits, which indicates their identical origin, most frequently connected with the natural content.

Keywords: bottom sediment, heavy metals, total content, soluble forms

Bottom sediments accumulated in water reservoirs constitute a very important part of ecosystems, play an important role in their functioning and element cycling between individual components of soil and groundwater system [1, 2]. Bottom sediments play

¹ Department of Agricultural and Environmental Chemistry, University of Agriculture in Krakow, al. A. Mickiewicza 21, 31–120 Kraków, Poland, phone/fax: +48 12 662 43 41, email: Agnieszka.Baran@ur.krakow.pl

² Department of Water Engineering and Geotechnics, University of Agriculture in Krakow, al. A. Mickiewicza 24/28, 30–059 Kraków, Poland, phone: +48 12 662 40 52, fax: +48 12 663 11 70, email: rmtarnaw@cyf-kr.edu.pl

the role of a natural filter and are indicators of the degree of environmental degradation. Heavy metals constitute a significant part of these pollutants, which at some concentrations may be toxic, they also reveal durability of forms enabling their migration to considerable distances. Moreover, elevated concentrations of heavy metals inhibit the processes of water self-cleaning, disturbing biological balance of water ecosystems. At this point it should be mentioned that the forms of trace heavy metals (total and soluble) occurring in the sediments are very important from the ecological point of view because some are toxic (Pb, Cd), whereas in excess all are harmful for living organisms [3–5].

Total element contents are very often taken into consideration because they are used as indicators of the degree of the environmental pollution [2, 4–8]. Still, total contents are not the best indicator of heavy metal bioavailability and mobility. The investigations aimed at an assessment of the content and solubility of heavy metals in bottom sediments of the Chancza water reservoir.

Materials and methods

Chancza retention reservoir is localized on the Czarna Staszowska River close to the Staszow town in the south-eastern part of the Swietokrzyskie province. The area is a part of The Kielce Upland macroregion and particularly the Nida Basin macroregion and mezoregions of the Szydłowski Upland and Orłowski Range. The valley bottom is lined with alluvia built of coherent grounds (silts, loams and clays) and fine or medium grained quartz sands. The Czarna Staszowska River is a left bank tributary to the Vistula River, whereas its waters and Chancza reservoir waters are classified to III water purity class [9]. The main tasks of the reservoir which was commissioned for operation in 1984 comprise: meeting the current water requirements of industrial and municipals users, flood waves reduction and compensation of water flows, conditions for tourism and recreation. Earth dam with a concrete spillway and outlet block

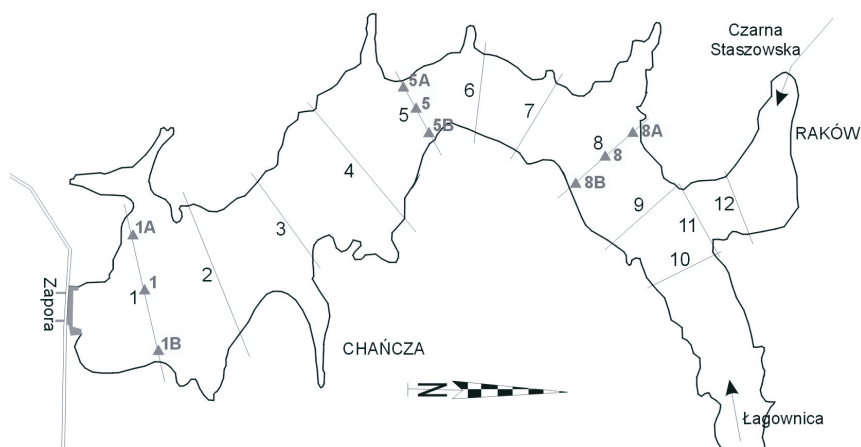

Fig. 1. Chancza water reservoir with marked measuring cross sections and the places of collected bottom sediment

closes the 475 km² river basin enabling formation of a reservoir with 24 Mm³ capacity and 11 m deep. Field works were conducted in September 2009. The bottom sediments were sampled from previously identified cross-sections characteristic for individual reservoir zones: inlet – section 8; middle – section 5; the dam-side – section 1 (Fig. 1).

Bottom sediment was sampled along each section, in three points in the vicinity of the right and left bank and in the middle of the cross-section. In order to average the collected material, the samples were collected from 6 points within the radius of 5–8 meters from the appointed location. The sediment was sampled using Ekman's sampler. The bottom sediments were classified to the deposits with granulometric composition of loamy sand (cross-section 1), loam (cross-section 5) and silt loam (cross-section 8) with neutral pH (Table 1).

Table 1

Selected properties of bottom sediments

Cross sections	pH		CaCO ₃	Organic matter	C-organic	N-total	Fe
	H ₂ O	KCl	[%]		[g · kg ⁻¹ d.m.]		
1	7.16	7.01	3.20	9.97	38.66	2.87	14.54
5	7.31	7.22	2.10	6.08	36.65	2.23	11.30
8	7.04	6.86	2.30	11.22	31.37	3.31	18.92

Total contents of heavy metals (Zn, Cu, Ni, Cr, Pb and Cd) and their forms soluble in 1 mol HCl, in 0.01 mol CaCl₂ · dm⁻³ and in distilled water were assessed in air-dried samples of the sediments. Total contents of heavy metals in the sediments were assessed after hot mineralization in a mixture of HNO₃ and HClO₃ acids (3:2). Extraction of the soluble metal forms from the deposits was conducted using static method through a single shaking of sediment samples with the solution at the sediment to solution ratio 1:10 and extraction time 1 h (1 mol HCl · dm⁻³) and 2 hrs (0.01 mol CaCl₂ and H₂O) [8, 10, 11]. Metal concentrations in the obtained solutions were assessed using ICP-AES method on JY 238 ULTRACE apparatus, (Jobin Von Emission). Metals soluble 1 mol HCl · dm⁻³ allow to estimate their mobilization in result of acidification of the environment in which they are deposited. Application of calcium chloride makes possible isolation from the sediments of a readily available heavy metal fraction which under natural conditions may release from the sediments posing a real hazard to ground and water environment [4]. On the other hand, water soluble components will mobilize and translocate from the sediments under the influence of precipitation water, immediately after their supply to the environment. Statistical computations comprised the basic parameters: arithmetic mean, standard deviation, median, minimum, maximum, variability coefficient and Person correlation coefficient. Statistical analysis was conducted using Statistica 8.0 programme.

Results

Total contents of heavy metals in the samples of analyzed bottom deposit ranged from 61.50–212.00 mg Zn; 6.50–89.60 mg Cu; 5.25–30.20 mg Cr; 5.05–29.90 mg Ni;

13.90–43.15 mg Pb; trace – 0.86 mg Cd · kg⁻¹ d.m. (Table 2). In view of their quantity, heavy metals in the deposits, irrespective of the analyzed cross-section, formed the following order: Zn > Cu > Pb > Cr > Ni > Cd, whereas concerning their diversification, the order was as follows Cu > Ni > Zn, Cd > Cr > Pb (Table 2). The highest metal concentrations were assessed in cross-section 8 on the inlet to the reservoir, the same samples contained also the highest amount of colloidal fraction, then in dam-side cross-section 1, where the highest proportion (ca 92 %) of sand fraction was determined. The lowest concentrations of heavy metals were noted in cross-section 5 in the middle part of the reservoir, where silt fraction dominated. Heavy metal contents in the bottom sediments collected from the middle of the reservoir (cross-section 5) were by 52 % Zn, 45 % Cu, 62 % Ni, 56 % Cr, 48 % Pb and 31 % Cd lower in comparison with the sediments sampled on the reservoir inlet (cross-section 8).

Table 2

Total content of heavy metals in bottom sediment

Cross sections	Zn	Cu	Ni	Cr	Pb	Cd
	[mg · kg ⁻¹ d.m.]					
1	111.83	23.10	13.87	17.90	28.45	0.50
1A	93.75	51.10	10.45	17.57	19.13	0.44
1B	104.00	55.65	11.50	20.48	20.88	0.47
Average	104.43	45.46	12.21	18.54	23.62	0.47
5	62.33	7.14	5.42	6.67	14.50	0.29
5A	72.50	41.55	6.65	11.73	14.75	0.47
5B	99.00	41.00	10.40	17.35	20.73	0.43
Average	75.71	27.14	7.19	11.16	16.35	0.36
8	203.17	15.90	26.15	28.60	41.10	0.36
8A	134.25	89.20	13.65	24.90	24.63	0.85
8B	107.75	60.20	13.22	21.28	23.52	0.62
Average	156.21	49.41	18.89	25.45	31.37	0.52
Statistical parameters						
Average	112.12	40.67	12.76	18.39	23.78	0.50
Standard deviation	43.51	24.4	6.37	6.90	8.62	0.20
Median	105.00	44.65	11.90	18.30	21.50	0.51
Minimum	61.50	6.50	5.05	5.25	13.90	trace
Maximum	212.00	89.60	26.90	30.20	43.15	0.86
V%	39	61	50	38	36	39
Norm ^a	< 1000	< 150	< 75	< 200	< 200	< 7.5
Geochemical background ^b	25–50	10–20	< 10	< 10	< 25	1–3

^a [18], ^b [19].

Numerous investigations have shown that the content of individual metals grows from the most coarse to the finest fraction [1, 12–14]. Obtained results did not corroborate this dependence because no typical phenomenon of grain segregation, encountered on the other hydraulic structures, occurs in the Chancza reservoir. It may

be caused by a considerable shallowing of the reservoir inlet part, overgrowing with aquatic vegetation or unprepared bowl, ie not removed vegetation including trunks and roots of trees and bushes. Persistent low-level water states caused that the supplied bedload was stopped before the reservoir inlet. The situation changes during high water states when the flood wave carries coarser bottom material into further reservoir zones at the same time floating fine mineral fractions. Diminishing the reservoir width in the middle zone causing a local increase in velocity may contribute to increased floating force of the particles secondarily included in the sediment transport. Sand deposits in the dam-side zone may also constitute of abrasion products (banks are sandy beaches) and indigenous deposits lining the Czarna Staszowska River valley.

Beside knowledge about the total heavy metal content in the sediment, also knowing their readily soluble forms is most useful because of their possible mobilization from the solid phase and penetrating into aquatic environment. The content or chemical element forms readily soluble in distilled water and 0.01 mol CaCl_2 and in 1 mol $\text{HCl} \cdot \text{dm}^{-3}$ in the analyzed sediment may inform about bottom deposits effect on the environment (Table 3).

Table 3

Content of soluble forms in H_2O ; 0.01 mol CaCl_2 and 1 mol $\text{HCl} \cdot \text{dm}^{-3}$ heavy metals in bottom sediment

Cross-sections		Zn	Cu	Ni	Cr	Pb	Cd
		[$\text{mg} \cdot \text{kg}^{-1} \text{ d.m.}$]					
1	H_2O	0.06	0.63	n.o. ^a	n.o.	0.06	n.o.
5		0.02	0.42	n.o.	n.o.	0.04	n.o.
8		0.07	1.18	n.o.	n.o.	0.08	n.o.
Average \pm SD		0.05 \pm 0.03	0.74 \pm 0.49	—	—	0.06 \pm 0.02	—
% total		0.04	1.82	—	—	0.25	—
V %		53	66	—	—	31	—
1	CaCl_2	0.51	1.99	0.07	0.08	0.25	n.o.
5		0.06	1.30	0.04	0.04	0.14	n.o.
8		0.71	3.32	0.09	0.11	0.12	n.o.
Average \pm SD		0.42 \pm 0.30	2.22 \pm 0.97	0.06 \pm 0.02	0.07 \pm 0.02	0.17 \pm 0.7	—
% total		0.37	5.46	0.47	0.38	0.71	—
V %		71	44	40	33	41	—
1	HCl	39.19	8.26	3.58	1.31	13.04	0.13
5		32.94	6.20	2.07	0.87	9.57	0.06
8		81.44	14.08	2.72	2.15	16.69	0.52
Average \pm SD		51.18 \pm 25.3	9.51 \pm 4.8	2.79 \pm 1.7	1.44 \pm 0.66	13.81 \pm 7.1	0.23 \pm 0.2
% total		45.65	23.38	21.87	7.83	58.07	48.00
V %		49	51	61	46	51	99

^a n.o. – undetectable value.

Heavy metal solubility assessed in the conducted analyses depended primarily on their total content in bottom deposits. This was true for zinc, copper, chromium, lead

and cadmium, whose highest total content and solubility were registered in the sediments collected in cross section 8 on the reservoir inlet, whereas lower in dam-side cross-section 1 and the lowest in cross-section 5 (Table 3, Fig. 2).

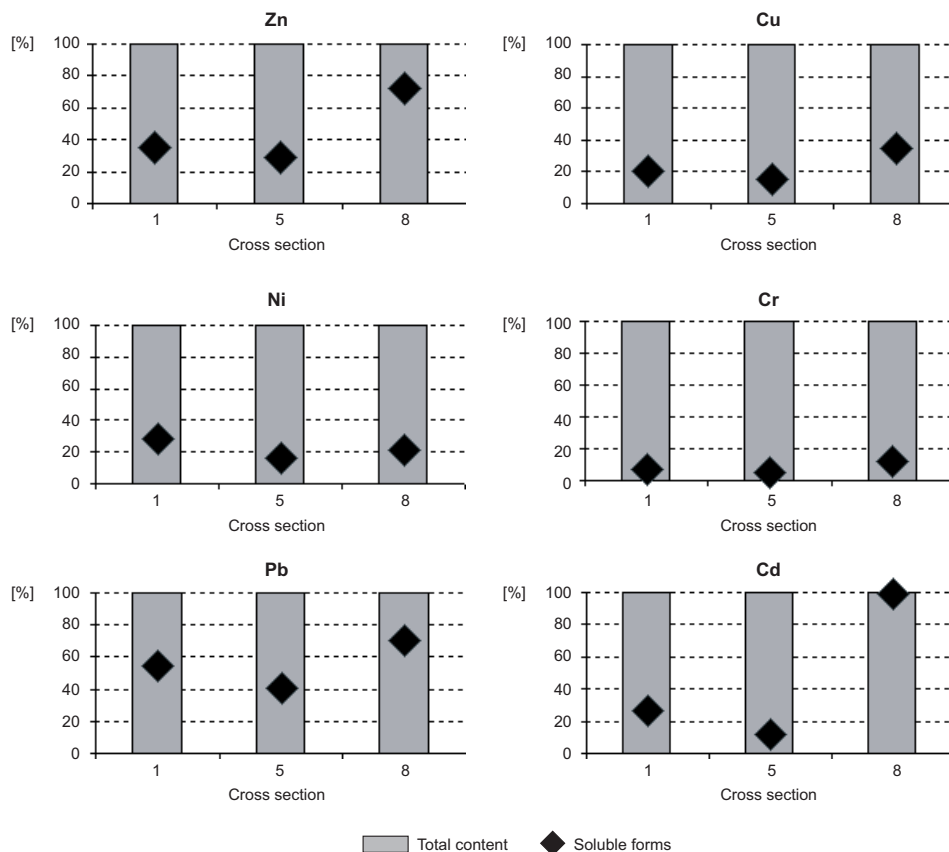

Fig. 2. Percent share of available forms ($1 \text{ mol HCl} \cdot \text{dm}^{-3}$) of trace elements in their total contents in bottom sediment

Heavy metal solubility in distilled water and calcium chloride was very poor, which is connected with low concentration of hydrogen ions in the analyzed sediments (Table 1). Heavy metal solubility in distilled water and calcium chloride with reference to their total content constituted respectively: 0.04 and 0.37 % for Zn; 1.82 and 5.46 % for Cu and 0.25 and 0.71 % for Pb; 0.47 % for Ni and Cr (0.01 mol CaCl_2) (Table 3). The solubility in $1 \text{ mol HCl} \cdot \text{dm}^{-3}$ was better and depending on the sampling place ranged from 34.95 to 72.64 % (zinc), from 15.24 to 34.62 % (copper) from 16.22 to 28.06 % (nickel), from 4.73 to 11.69 (chromium), from 40.24 to 70.19 (lead) and from 12 to almost 100 % (cadmium) in comparison with their total content (Fig. 2).

In the opinion of many authors the $0.01 \text{ mol CaCl}_2 \cdot \text{dm}^{-3}$ solution, unlike $1 \text{ mol HCl} \cdot \text{dm}^{-3}$ solution, is counted among solutions with low extraction power and ability

for assessing so called bioavailable (active) fraction of heavy metals [7, 4]. In the presented research as may have been expected, lesser amounts of the analyzed elements were assessed in the $0.01 \text{ mol CaCl}_2 \cdot \text{dm}^{-3}$ extract (Table 3). Generally, hydrochloric acid leaches metals bound to exchangeable, carbonate, Fe/Mn oxides and organic matter fractions. Copper, lead, chromium and nickel are commonly regarded as the least mobile elements in the environment, zinc and cadmium are counted among the most mobile ones, whereas manganese and iron place in the middle [15]. Considering the elements analyzed in the presented investigations, the best average solubility in $1 \text{ mol HCl} \cdot \text{dm}^{-3}$ characterized Pb, followed by $\text{Cd} > \text{Zn} > \text{Cu} > \text{Ni} > \text{Cr}$, whereas in $0.01 \text{ mol CaCl}_2 \cdot \text{dm}^{-3}$: $\text{Cu} > \text{Pb} > \text{Ni} > \text{Cr} > \text{Zn}$. Numerous investigations have shown that sediment reaction may affect heavy metal mobility in the environment [1, 14]. An opinion has been prevailing that metals may pass into less soluble forms at higher pH values [14, 16]. In the presented research a significant influence of the sediment reaction was observed on diminishing solubility of most of the investigated elements. This phenomenon has been corroborated by negative and significant values of correlation coefficients between pH value and element content in the sediments (Table 4). Linear dependence between individual heavy metals in the sediment may result from their geochemical bonds but may also indicate their mobility and sources of origin [1]. The existence of such dependencies has been checked in the analyzed sediments. For this purpose linear correlation coefficients were computed between individual pairs of metals (Table 4). In the studied bottom sediments a strong dependence was found between the respective pairs of metals: Zn and Cr, Ni, Pb; Ni and Cr, Pb and Cr and Pb with linear correlation coefficient exceeding 0.8 and $p \leq 0.001$ and Cu and Cd (Table 4). Strong linear correlations between individual pairs of heavy metals confirm their identical origin, frequently associated with natural content. In the analyses of the interrelations between the content of various metals, iron was regarded individually. The correlation between iron content and the concentration of other element may allow to differentiate the sediments with natural content of element from those enriched in result of human activity [2, 17]. A lack of significant correlation between iron and another heavy metal may point to their anthropogenic origin [1]. In samples analyzed in the presented research, in most cases Fe was significantly positively correlated with Zn, Cr, Pb and Ni, non-significantly with Cu and Cd; yet, at the same time the amount of these metals in the samples has been relatively small. A comparison of heavy metal values in the samples with values of geochemical background from reservoir localization area, shows that only Cd concentration within the whole reservoir did not exceed the background values. Ni and Pb concentrations in the reservoir middle zone were lower than the values of geochemical background, whereas the values for the other metals (Zn, Cu and Cr) exceeded these value considerably (Table 2). It has been also confirmed by the assessment of the degree of the studied sediments pollution as stated in the Decree of the Minister of the Natural Environment dated 16 April 2002 on the kinds and concentrations of substances which cause that the yield is polluted [18]. According to the above-mentioned criterion, bottom sediments from the Chancza Reservoir were not polluted with heavy metals (Table 2).

Table 4

The correlation coefficients between content of heavy metals, organic matter and pH in bottom sediment

Parameters		Total content						pH	
		Zn	Cu	Ni	Cr	Pb	Cd	H ₂ O	KCl
Total content	Cu	0.07							
	Ni	0.98***	-0.08						
	Cr	0.87***	0.42	0.84***					
	Pb	0.95***	-0.14	0.98***	0.80***				
	Cd	0.17	0.69**	0.14	0.45	0.19			
Soluble forms	Zn	0.94***	0.08	0.90***	0.81***	0.87***	0.25	-0.56*	—
	Cu	0.82***	-0.07	0.84***	0.71***	0.82***	0.04	0.55*	—
	Ni	-0.32	0.68**	-0.35	0.02	-0.29	0.78***	-0.14	-0.15
	Cr	0.94***	-0.04	0.91***	0.77***	0.91***	0.25	-0.50*	—
	Pb	-0.01	0.97***	-0.08	0.42	-0.16	0.55*	-0.55*	-0.35
	Cd	0.82***	-0.45	0.82***	0.49*	0.78***	-0.33	-0.24	—
pH	H ₂ O	-0.62**	-0.55*	—	—	-0.56*	-0.48*		
	KCl	—	-0.37	—	—	-0.67**	-0.35		
Org. matter		0.89***	-0.13	0.92***	0.77***	0.95***	0.28		
Fe		0.91*	0.34	0.89*	0.87*	0.86*	0.17		

Significant ***p ≤ 0.001, **p ≤ 0.01, *p ≤ 0.05.

Summing up, heavy metals form a protective barrier against metal penetration to waters but at the same time may be a potential source of pollution in result of physicochemical changes in the soil and groundwater environment. Moreover, determining the level of heavy metal solubility in bottom sediments is very important because of a potential of their mobilization from the solid phase and penetration to aquatic environment where they become bioavailable [1]. The issue has been addressed in the presented paper which investigated total heavy metal content and their soluble forms.

Conclusions

1. The analyzed sediments do not reveal heavy metal contamination level which would pose a hazard to the aquatic or terrestrial environment. However, their Zn, Cu and Cr concentrations have been higher than geochemical background for water sediments from the area where the reservoir is situated.

2. Total heavy metal contents in the investigated bottom sediment were as follows: 61.50–212.00 mg Zn; 6.50–89.60 mg Cu; 5.25–30.20 mg Cr; 5.05–29.90 mg Ni; 13.90–43.15 mg Pb; trace – 0.86 mg Cd · kg⁻¹ d.m.

3. The highest concentrations of heavy metals were assessed in the sediment samples collected on the reservoir inlet, then at the dam-side, whereas the lowest amounts were found in the samples from the middle part of the reservoir.

4. Solubility of heavy metals depended on the extracting solution used and their total concentrations in the analyzed sediment.

5. A considerable leachability of heavy metals with 1 mol HCl · dm⁻³ was established, which may indicate a potential threat for the environment from the leachates from the stored dredged sediment.

6. The best average solubility in 1 mol HCl · dm⁻³ characterized Pb, followed by Cd > Zn > Cu > Ni > Cr, whereas in 0.01 mol CaCl₂ · dm⁻³: Cu > Pb > Ni > Cr > Zn.

7. Strong linear correlations were demonstrated between individual pairs of heavy metals in bottom deposits, which indicates their identical origin, most frequently connected with the natural content.

References

- [1] Aleksander-Kwarczak U.: Rozmieszczenie metali śladowych w rdzeniach osadów wybranych rzek Polski. Wyd. AGH, Kraków 2007, pp. 114.
- [2] Rabajczyk A.: Cent. Eur. J. Chem. 2011, **9**(2), 357–366.
- [3] Loska K. and Wiechuła D.: Chemosphere 2003, **51**, 723–733.
- [4] Popena A., Malina G. and Siedlicka E.: Ochr. Środow. Zasob. Natur. 2007, **32**, 246–252.
- [5] Madeyski M., Michalec B. and Tarnawski M.: *Silting of small water reservoirs and quality of sediments*, [in:] Infrastructure and ecology of rural areas, Ser.: monograph 11, Polish Academy of Science, Commission of Technical Infrastructure, Kraków 2008, pp.76.
- [6] Meyers P.A.: Org. Geochem. 1997, **27**(5/6), 213–250.
- [7] Dziadek K. and Waclawek W.: Chem., Dydak., Ekol., Metrol. 2005, **10**(1–2), 33–44.
- [8] Gembarzewski H., Kamińska W. and Korzeniowska J.: Prace Kom. PTG 1987, **99**, 1–9.
- [9] WIOŚ Kielce: <http://kielce.pios.gov.pl/raporty/rocz/2009/raport%202009.pdf>
- [10] Houba V.J.G., Novozamsky I., Lexmond Th.M. and Van der Lee J.J.: Comm. Soil Sci. Plant Anal. 1990, **21**, 19–20.
- [11] Karoń B. and Gediga K.: Zesz. Probl. Post. Nauk. Roln. 2000, **471**, 97–102.
- [12] Bojakowska I., Gilowicz T. and Sokolowska G.: *Wyniki monitoringu geochemicznego osadów wodnych Polski w latach 1996–1997*. Bibl. Monitor. Środow. 1998, 62.
- [13] Adamie E. and Helios-Rybicka E.: Polish J. Environ. Stud. 2000, **11**(6), 675–688.
- [14] Helios-Rybicka E.: Geologia 1997, **39**, 89–97.
- [15] Badora A.: Zesz. Probl. Post. Nauk Roln. 2002, **482**, 21–36.
- [16] Mercik S. and Stępień W.: Zesz. Probl. Post. Nauk Roln. 2000, **471**, 395–402.
- [17] Presley B.J., Taylor R.J. and Boothe P.N.: Mar. Environ. Res. 1992, **33**, 267–282.
- [18] Rozporządzenia Ministra Środowiska z dnia 16 kwietnia 2002 r. w sprawie rodzaju oraz stężeń substancji, które powodują, że urobek jest zanieczyszczony, DzU 2002, nr 55, poz. 498.
- [19] Lis J. and Pasieczna A.: Atlas geochemiczny Polski 1:2500000. Wyd. PIG, Warszawa 1995.

OCENA ZAWARTOŚCI I ROZPUSZCZALNOŚCI METALI CIĘŻKICH W OSADACH DENNYCH ZBIORNIKA CHAŃCZA

¹ Katedra Chemii Rolnej i Środowiskowej

² Katedra Inżynierii Wodnej i Geotechniki

Uniwersytet Rolniczy im. Hugona Kołłątaja w Krakowie

Abstrakt: Celem badań była ocena zawartości i rozpuszczalności metali ciężkich w osadach dennych zbiornika Chańcza, zlokalizowanego na rzece Czarnej Staszowskiej (woj. świętokrzyskie). Próbkę osadu dennego pobrano z wyznaczonych przekroi będących charakterystycznymi dla danej strefy zbiornika: wlotowej – przekrój 8, środkowej – przekrój 5, przy zaporowej – przekrój 1. Wzdłuż każdego z przekrojów pobrano osad denny w trzech punktach w okolicach brzegów (prawego, lewego) oraz w środku przekroju.

W celu uśrednienia pobieranego materiału próbki pobrane były z 6 miejsc w promieniu 5–8 metrów od wyznaczonej lokalizacji. Pobranie osadu wykonano za pomocą próbnika Ekmana. W powietrznie suchych próbkach osadów oznaczono ogólną zawartości metali ciężkich (Zn, Cu, Ni, Cr, Pb, Cd) oraz ich formy rozpuszczalne w 1 mol HCl, w 0,01 mol $\text{CaCl}_2 \cdot \text{dm}^{-3}$ i w wodzie destylowanej metodą ICP-AES. Największą zawartość metali ciężkich wykazano w próbkach osadów pobranych na wlocie zbiornika, następnie przy zaporze, a najmniejszą w środkowej części zbiornika. Rozpuszczalność metali ciężkich była uzależniona od użytego roztworu ekstrahującego oraz całkowitej ich zawartości w badanym osadzie. Spośród badanych metali największą średnią rozpuszczalnością w 1 mol HCl $\cdot \text{dm}^{-3}$ charakteryzował się Pb, następnie $\text{Cd} > \text{Zn} > \text{Cu} > \text{Ni} > \text{Cr}$, natomiast w 0,01 mol $\text{CaCl}_2 \cdot \text{dm}^{-3}$: $\text{Cu} > \text{Pb} > \text{Ni} > \text{Cr} > \text{Zn}$. Wykazano silne korelacje liniowe pomiędzy poszczególnymi parami metali ciężkich w osadach dennych, co wskazuje na jednakowe ich pochodzenie, najczęściej związane z zawartością naturalną.

Słowa kluczowe: osad denny, metale ciężkie, zawartość całkowita, formy rozpuszczalne

Petr ŠKARPA¹

MONITORING THE CHANGES IN TOTAL CONTENTS OF MANGANESE, COPPER AND ZINC IN SOILS FROM LONG-TERM STATIONARY EXPERIMENTS

MONITORING ZMIAN CAŁKOWITYCH ZAWARTOŚCI MANGANU, MIEDZI I CYNKU W GLEBACH PODDAWANYCH DŁUGOTERMINOWYM DOŚWIADCZENIOM ROLNICZYM

Abstract: The objective of the long-term stationary experiment was to discover the effect of the year, production region, soil kind and soil type on total contents of micronutrients (Mn, Cu and Zn) in the soils. In the years 1982 to 1998 the soil was sampled in 7 selected localities. Analyses and extractions determining the total content of metals were carried out by means of mineralization in the HF – H₂O₂ – HNO₃ open system. The AAS method was used to determine the contents of the micronutrients. The content of manganese ranged between 296.2 and 978.6; copper between 6.1 and 25.7 and zinc between 29.5 and 99.8 mg · kg⁻¹ of soil. During the experimental period 1982–1998 the total content of Mn and Zn decreased (by 7.9 % and 3.6 %, respectively), but was not statistically significant ($p < 0.05$). During the 15 years of the experiment the total amount of copper in the soil increased by 7.0 %. In comparison with the potato growing region the contents of all the micronutrients in the sugar-beet growing region were higher. The highest and statistically highly significant difference ($p < 0.001$) was that of copper (45.6 % increase). In terms of the soil kind the lowest contents of Mn and Cu were monitored on light soil. The total content of zinc on light soil and medium-heavy soil was comparable. With an increasing proportion of clay particles in the soil the contents of the micronutrients increased significantly ($p < 0.001$). In comparison with light soil, in heavy soil the contents of the metals increased; Mn by 38.9; Cu by 48.2 and Zn by 19.4 %. The levels of Cu and Zn were also affected by the soil type. The contents of these micronutrients were statistically ($p < 0.001$) the highest in chernozem (24.6 and 71.1 mg · kg⁻¹ of soil, respectively). The content of Mn was the highest in brown soil (714.3 mg · kg⁻¹ of soil). Graded rates of fertilisers did not have a significant ($p < 0.05$) effect on the total contents of metals. The differences were more marked in the treatment where liming was not carried out; here we monitored the greatest decrease in the contents of Mn, Cu and Zn, ie by 7.3, 23.8 and 9.4 %, respectively, compared with the control.

Keywords: long-term experiment, total zinc, total manganese, total copper

Soil is characterised as the most complicated, most dynamic and most reactive component on Earth [1]. Soil is a key part of the environment and irreplaceable source

¹ Department of Agrochemistry, Pedology, Microbiology and Plant Nutrition, Mendel University in Brno, Zemědělská 1, 613 00 Brno, Czech Republic, phone: + 420 545 133 345, email: petr.skarpa@mendelu.cz

of most of the bio-chemically active micronutrients influencing human beings through plants and animals. Important biogenic microelements are manganese, copper and zinc [2, 3]. Their total levels in the soil are based particularly on the mineral composition of the soil, soil type, content of clay particles (soil kind), content of organic matter in the soil, soil reaction etc [4–7]. The content of micronutrients in the soil is considerably affected by anthropogenic activities. An important source of micronutrients which increases their levels in the soil are indisputably fertilisers (particularly nitrogenous and phosphorus), calcareous matter, farmyard manure, slurry, pesticides and others [4, 8, 9].

The aim of this study was to evaluate changes in total content of manganese, copper and zinc in soil in long-term experiment.

Material and methods

The experiment was established in 7 localities of potato growing regions (altitude 400–650 m a.s.l., annual average temperature 5–8 °C, annual average precipitation 550–900 mm, predominate cambisols) and sugar-beet growing regions (altitude 250–350 m a.s.l., annual average temperature 8–9 °C, annual average precipitation 500–650 mm, predominate chernozems and haplic luvisols) as a long-term small-plot stationary trial by the Central Institute for Supervising and Testing in Agriculture between 1982 and 1998. Table 1 gives the characteristics of the localities.

Table 1

The characteristic of localities

Locality	Growing regions	Altitude m a.s.l.	Annual average		Reference soil groups	Soil textural class
			temperature [°C]	precipitation [mm]		
Horazdovice	potato	470	7.4	573	Cambisols	sandy
Svitavy	potato	460	6.5	624	Cambisols	sandy
Chrastava	potato	345	7.1	798	Luvisols	loamy
Stankov	potato	370	8.3	443	Luvisols	clay
Puste Jakartice	sug.-beet	295	8.0	640	Luvisols	loamy
Uhersky Ostroh	sug.-beet	196	9.2	551	Luvisols	loamy
Zatec	sug.-beet	247	8.3	451	Chernozems	clay

Soil type (FAO soil taxonomy), soil textural class [10].

The experiment comprised 6 combinations of fertilization, in 4 replications. Table 2 shows the average contents of N, P and K, which were applied in organic fertilizers (farm manure) and mineral fertilizers at three levels (low – N₁P₁K₁, medium – N₂P₂K₂, high – N₃P₃K₃). Organic fertilizers were applied once every 4 years; 40 Mg ha⁻¹ of farm manure was incorporated in the sugar-beet growing region to maize for silage and to sugar-beet and in the potato growing region to potatoes.

Table 2

Treatments of the experiment

Treatments of fertilization	Average content of nutrients in fertilizers [kg · ha ⁻¹ · year ⁻¹]					
	Nitrogen		Nitrogen		Nitrogen	
	PGR ^a	SGR ^b	PGR	SGR	PGR	SGR
No fertilized	0	0	0	0	0	0
Farm. manure	25	25	8	8	35	35
Farm. manure + N ₁ P ₁ K ₁	83	83	31	29	92	86
Farm. manure + N ₂ P ₂ K ₂	113	112	43	41	125	116
Farm. manure + N ₃ P ₃ K ₃	142	140	59	57	166	154
Farm. manure + N ₃ P ₃ K ₃ without liming	142	140	59	57	166	154

^a PGR – potato growing regions; ^b SGR – sugar-beet growing regions.

Soil was sampled in the localities in autumn 1982 and 1998. Soil samples were taken from 0–30 cm depth. Samples were dried naturally. The total content micronutrients (manganese, copper and zinc) of the soil in its dry state was estimated by the method of Houba et al [11] with the soil extracted in the mixture of HF – H₂O₂ – HNO₃ and measured by atomic absorption spectrometry (AAS) on the ContraA 700 spectrometer (Analytic Jena).

The results of chemical soil analyses were computer-processed and set up using the Microsoft Excel editor. The Statistica 7.1 programme was used for the determination of the overall characteristics. Arithmetic means were calculated when evaluating the results. To elaborate the significance of differences among the arithmetic means of each characteristic we used the mono-factor and two-factor analysis of variance followed by testing at a 95% ($p < 0.05$) level of significance using Tukey test.

Results and discussion

Manganese. Manganese is the tenth-most abundant element on the surface of the earth [2]. Its natural content in soils of the Czech Republic ranges between 80 and 2220 mg · kg⁻¹ of soil [12]. Bohn et al [13] reported that the average amount of total Mn ranges between 850 and 1000 mg · kg⁻¹. In our experiment the content of manganese ranged between 296.2 and 978.6 mg · kg⁻¹. During the experiment the total content of Mn decreased by 7.9 %, but this decrease was not statistically significant [F (1; 164) = 3.312; $p = 0.071$] (Table 3). The reason of the statistically insignificant effect of the production region on the Mn content in the soil [F (1; 164) = 3.646; $p = 0.058$] were significant differences in the Mn content among the individual localities. Nonetheless its average value in the sugar-beet growing region was by 9.1 % higher than in the potato-growing region (Table 4). Only the factor of the soil kind was statistically significant [F (2; 163) = 26.536; $p < 0.001$]. A significant difference was discovered between light soil and the medium-heavy and heavy soils (Table 5). Katyál a Sharma

[14], Trebichavsky et al [12], Raji et al [15], Rinaudo [16] reported that due to the content of clay particles the total content of Mn increased. In terms of the soil type the highest statistically significant content of Mn was detected in brown soil [F (2; 163) = 52.607; $p < 0.001$]. We compared the soils and discovered that the content of manganese was the lowest in cambisols; in chernozem it was by 11 % higher (Table 6). Wang et al [17] reported the highest content of Mn in chernozem. The total amounts of manganese in the soil after the respective fertiliser treatments did not significantly differ [F (5; 160) = 0.165; $p = 0.975$]. Podkolzin et al [18] presented similar conclusions. By contrast Kurakov et al [19] reported that the Mn content increased due to long-term application of fertilisers. Table 7 shows that the content of Mn was the highest in the treatment with no fertilisers (treatment 1) and the lowest where the highest amount of mineral fertilisers was applied without liming (treatment 6).

Copper. The total content of copper in non-contaminated soils ranges between 2 and 200 mg · kg⁻¹ of soil [6, 13]. The average contents are quoted to range between 10 and 50 mg · kg⁻¹ of soil [4, 20, 21]; in the Czech Republic the average Cu content is 26 mg · kg⁻¹ of soil [12]. In our experiment the amount of Cu ranged between 6.1 and 25.7 mg · kg⁻¹ of soil, an equivalent to the lower half of its natural content reported by these authors. As Table 3 shows during the experiment the content of copper increased by 7 %, but not statistically significantly [F (1; 164) = 1.412; $p = 0.236$]. However, the influence of the production region on the copper content was statistically significant [F (1; 164) = 56.401; $p < 0.001$]. In the sugar-beet region the content of copper was by 45.6 % higher than in the potato-growing region (Table 4). According to Trebichavsky et al [12], Kabata-Pendias, Pendias [4] and Yu et al [22] the soil kind also significantly affects the content of copper in the soil and confirms that the level copper in the soil increases due to the increasing amount of clay particles [F (2; 163) = 23.576; $p < 0.001$]. While the copper content on medium-heavy soil was by 7.3 % higher, the significantly highest content was monitored on heavy soil (Table 5). Likewise Wang et al (2003) reported a positive correlation between the copper content and clay particles. Another factor affecting the copper content was the soil type. The statistically significantly highest level of copper was detected in chernozem [F (2; 163) = 60.237; $p < 0.001$]. In brown soil and cambisol the content was lower by 39.8 and 44.3 %, respectively (Table 6). Barker and Pilbeam [2] also reported that the level of copper was the highest in chernozem soils. Graded rates of fertilizers had no statistically significant effect on the total amount of soil copper [F (5; 160) = 1.052; $p = 0.389$] (Table 7). Erhart et al [23] arrived at the same conclusions. In the experiment its amount gradually decreased with increasing rates of nutrients contained in the applied organic and mineral fertilisers. Much like Mn, also the copper content was the lowest in treatment 6.

Zinc. Trebichavsky et al [12] reported that the average total content of zinc in agricultural soils of the Czech Republic ranges between 10 and 244 mg · kg⁻¹ of soil (82 mg · kg⁻¹) and that the worldwide average ranges between 50 and 60 mg · kg⁻¹ [13]. The total content of zinc in our experiment ranged between 29.5 and 99.8 mg · kg⁻¹ of soil. Much like manganese the average zinc content decreased during the experiment (Table 3), however not statistically significantly [F (1; 164) = 0.874; $p = 0.351$]. When compared with the other monitored micronutrients the effect of the production region on

the zinc content was the same as on Mn (Table 4). The zinc supply was higher in the sugar-beet growing region (by 5.1 %) [F (1; 164) = 1.696; p = 0.195]. In our experiment the contents of zinc on light soil and on medium-heavy soil were comparable. The level of zinc on heavy soil (Table 5) significantly differed from the above soil kinds [F (2; 163) = 11.369; p < 0.001]. Moreno et al [24], Kparamwang et al [25], Valladares et al [26] and Menezes et al [27] also discovered that the effect of clay on the content of soil zinc was significant. The effect of the soil type was similar as in the case of copper

Table 3

Total contents of microelements in soil [mg · kg⁻¹ d.m. soil] – Factor: year

Year	Mn	Cu	Zn
1982	636.6 a	15.7 a	61.4 a
<i>rel. %</i>	<i>100.0</i>	<i>100.0</i>	<i>100.0</i>
1998	586.0 a	16.8 a	59.2 a
<i>rel. %</i>	<i>92.1</i>	<i>107.0</i>	<i>96.4</i>

p < 0.05 – statistical significance at a 95% level of significance. Variants with identical letters express statistically insignificant differences.

Table 4

Total contents of microelements in soil [mg · kg⁻¹ d.m. soil] – Factor: growing regions

Growing regions	Mn	Cu	Zn
Potato growing regions	587.2 a	13.6 a	59.0 a
<i>rel. %</i>	<i>100.0</i>	<i>100.0</i>	<i>100.0</i>
Sugar-beet growing regions	640.8 a	19.8 b	62.0 a
<i>rel. %</i>	<i>109.1</i>	<i>145.6</i>	<i>105.1</i>

p < 0.05 – statistical significance at a 95% level of significance. Variants with identical letters express statistically insignificant differences.

Table 5

Total contents of microelements in soil [mg · kg⁻¹ d.m. soil] – Factor: soil textural class

Soil textural class	Mn	Cu	Zn
Sandy soil	471.0 a	13.7 a	56.7 a
<i>rel. %</i>	<i>100.0</i>	<i>100.0</i>	<i>100.0</i>
Loamy soil	676.2 b	14.7 a	56.6 a
<i>rel. %</i>	<i>143.6</i>	<i>107.3</i>	<i>99.8</i>
Clay soil	654.3 b	20.3 b	67.7 b
<i>rel. %</i>	<i>138.9</i>	<i>148.2</i>	<i>119.4</i>

p < 0.05 – statistical significance at a 95% level of significance. Variants with identical letters express statistically insignificant differences.

Table 6

Total contents of microelements in soil [$\text{mg} \cdot \text{kg}^{-1}$ d.m. soil] – Factor: reference soil groups

Reference soil groups	Mn	Cu	Zn
Cambisols	471.0 a	13.7 a	56.7 a
<i>rel. %</i>	<i>100.0</i>	<i>100.0</i>	<i>100.0</i>
Luvisols	714.3 b	14.8 a	58.5 a
<i>rel. %</i>	<i>151.7</i>	<i>108.0</i>	<i>103.2</i>
Chernozems	525.3 a	24.6 b	71.1 b
<i>rel. %</i>	<i>111.5</i>	<i>179.6</i>	<i>125.4</i>

$p < 0.05$ – statistical significance at a 95% level of significance. Variants with identical letters express statistically insignificant differences.

Table 7

Total contents of microelements in soil [$\text{mg} \cdot \text{kg}^{-1}$ d.m. soil] – Factor: Fertilization

Variant of fertilization	Mn	Cu	Zn
No fertilized	626.1 a	17.2 a	62.7 a
<i>rel. %</i>	<i>100.0</i>	<i>100.0</i>	<i>100.0</i>
Farm. manure	618.5 a	16.7 a	60.5 a
<i>rel. %</i>	<i>98.8</i>	<i>97.1</i>	<i>96.5</i>
Farm. manure + $\text{N}_1\text{P}_1\text{K}_1$	601.6 a	16.5 a	59.9 a
<i>rel. %</i>	<i>96.1</i>	<i>95.9</i>	<i>95.5</i>
Farm. manure + $\text{N}_2\text{P}_2\text{K}_2$	613.4 a	16.4 a	60.2 a
<i>rel. %</i>	<i>98.0</i>	<i>95.3</i>	<i>96.0</i>
Farm. manure + $\text{N}_3\text{P}_3\text{K}_3$	605.1 a	16.1 a	59.8 a
<i>rel. %</i>	<i>96.6</i>	<i>93.6</i>	<i>95.4</i>
Farm. manure + $\text{N}_3\text{P}_3\text{K}_3$ without liming	580.1 a	13.1 a	56.8 a
<i>rel. %</i>	<i>92.7</i>	<i>76.2</i>	<i>90.6</i>

$p < 0.05$ – statistical significance at a 95% level of significance. Variants with identical letters express statistically insignificant differences.

(Table 6). In cambisol and brown soil 56.7 and 58.5 $\text{mg Zn} \cdot \text{kg}^{-1}$, respectively, were detected, whereas the significantly highest Zn content was monitored in chernozem [$F(2; 163) = 11.247$; $p < 0.001$]. The results of Wang et al [17] also support this fact. Table 7 shows that fertilisation did not significantly affect the content of Zn or the contents of the other micronutrients [$F(5; 160) = 0.345$; $p = 0.884$]. The level of Zn was the lowest when fertilised with the highest rate of mineral fertilisers without liming (treatment 6) and was the highest when not fertilised; the difference was 9.4 %.

Podkolzin et al [18] also reported that long-term application of organic and mineral fertilisers had no marked effect on the content of soil Zn.

Conclusions

The results of a long-term stationary experiment showed that during the 17 years of the experiment the total contents of Zn and Mn decreased and the amount of Cu increased, but not significantly. The levels of all the micronutrients were higher in the sugar-beet region than in the potato-growing region and only Cu was significantly higher (by 45.6 %). In terms of the soil kind the levels of the micronutrients were the lowest in light soil. The levels of metals increased significantly with the increasing content of clay particles in the soil. In heavy soil the contents of Mn, Cu and Zn were by 38.9, 48.2 and 16.4 %, respectively, higher than the amounts monitored on light soil. The differences among the soil types were significant. The contents of Cu and Zn were the highest in chernozem; the significantly highest content of Mn was detected in Luvisol. Graded rates of organic and mineral fertilisers did not affect the total content of metals.

Acknowledgements

This work was supported by the project MŠMT No. 2B08039.

References

- [1] Tabatabai M.A.: *Soil organic matter testing: An overview*, [in:] Magdoff F.R. et al: Soil organic matter: Analysis and interpretation. SSSA, Madison, Wisconsin, USA, 1996.
- [2] Barker A.V. and Pilbeam D.J.: *Handbook of plant nutrition*, CRC Press, Boca Raton 2006, pp. 613.
- [3] Marschner H.: *Mineral Nutrition of Higher Plants*, 2nd ed., Academic Press, New York 2002, pp. 889.
- [4] Kabata-Pendias A. and Pendias H.: *Trace Elements in Soils and Plants*, 2nd ed., CRC Press, Boca Raton 1992.
- [5] Barber S.A.: *Soil Nutrient Bioavailability*, 2nd ed., Wiley, New York 1995, pp. 398.
- [6] Mortvedt J.J.: *Bioavailability of micronutrients*, [in:] Sumner M.E. (ed.): *Handbook of Soil Science*. CRC Press, Boca Raton 2000, 71–88.
- [7] Soumaré M., Tack F.M.G. and Verloo M.G.: *Comm. Soil Sci. Plant Anal.* 2003, **34**, 1023–1038.
- [8] Grupe M. and Kuntze H.: *J. Plant Nutr Soil Sci.* 1988, **151**(5), 319–324.
- [9] Rice P.J., Harman-Fetcho J.A., Teasdale J.R., Sadeghi A.M., McConnell L.L., Coffman C.B., Herbert R.R., Heighton L.P. and Hapeman C.J.: *Environ. Toxicol. Chem.* 2004, **23**(3), 719–725.
- [10] Shepard F.P.: *J. Sediment Petrol.* 1954, **24**(3), 151–158.
- [11] Houba V.J.G., Van Der Lee J.J., Novozamsky I. and Waling I.: *Soil and Plant Analysis, Part 5. Soil analysis procedures*, Wageningen Agric. University, The Netherlands, 1989.
- [12] Trebichavský J., Šavrdová D. and Blohberger M.: *Toxic Metals*, NSO – Ing. František Nekvasil, Kutná Hora 1997, pp. 509.
- [13] Bohn H.L., McNeal B.L. and O'Connor G.A.: *Soil chemistry*, 3rd ed. John Wiley & Sons, New York 2001, pp. 307.
- [14] Katyal J.C. and Sharma B.D.: *Geoderma* 1991, **49**(1–2), 165–179.
- [15] Raji B.A., Chude V.O. and Esu I.E.: *J. Arid. Environ.* 1998, **38**(4), 585–596.
- [16] Rinaudo C., Gastaldi D., Zerbinati O., Fornero E. and Berta G.: *Acta Geol. Sin.-Engl. Ed.* 2009, **83**(6), 1224–1231.

- [17] Wang S.P., Wang Y.F., Hu Z.Y., Chen Z.Z., Fleckenstein J. and Schnug E.: *Commun. Soil Sci. Plant Anal.* 2003, **34**(5–6), 655–670.
- [18] Podkolzin A.I., Lebedeva L.A., Ageev V.V. and Smetanova V.A.: *Agrokhimiya* 2002, **10**, 21–24.
- [19] Kurakov V.I., Minakova O.A. and Aleksandrova L.V.: *Agrokhimiya* 2006, **11**, 59–65.
- [20] Kubota J.: *Agron. J.* 1983, **75**, 913–918.
- [21] Adriano D.C.: *Trace Elements in the Terrestrial Environment*. Springer, New York 1986, pp. 533.
- [22] Yu S., He Z.L., Huang C.Y., Chen G.C. and Calvert D.V.: *J. Environ. Qual.*, 2002, **31**, 1129–1136.
- [23] Erhart E., Hartl W. and Putz B.: *J. Plant Nutr. Soil Sci. – Z. Pflanzenernahr. Bodenkd.* 2008, **171**(3), 378–383.
- [24] Moreno A.M., Perez L. and Gonzalez J.: *Suelo y Planta*, 1992, **2**(4), 757–771.
- [25] Kparmwang T., Esu I.E. and Chude V.O.: *Commun. Soil Sci. Plant Anal.* 1998, **29**(15–16), 2235–2245.
- [26] Valladares G.S., Gabrielli D.S., Glauca C., De Abreu C.A., De Camargo O.A. and Ferrero J.P.: *Bragantia* 2009, **68**(4), 1105–1114.
- [27] Menezes A.A., Dias L.E. and da Silva J.V.O.: *Rev. Bras. Cienc. Solo* 2010, **34**(2), 417–424.

MONITORING ZMIAN CAŁKOWITYCH ZAWARTOŚCI MANGANU, MIEDZI I CYNKU W GLEBACH PODDAWANYCH DLUGOTERMINOWYM DOŚWIADCZENIOM ROLNICZYM

Katedra Agrochemii, Gleboznawstwa, Mikrobiologii i Żywienia Roślin
Uniwersytet im. G. Mendla w Brnie

Abstrakt: Celem wieloletniego stacjonarnego doświadczenia było określenie wpływu roku, rejonu produkcji oraz typu i rodzaju gleby na całkowitą zawartość mikroelementów (Mn, Cu i Zn) w glebie. W latach 1982–1998 pobrano próbki gleby z 7 wybranych miejsc. Całkowite zawartości metali oznaczono po wcześniejszej mineralizacji w otwartym systemie HF – H₂O₂ – HNO₃. Zawartości mikroelementów oznaczano metodą AAS. Zawartość manganu wahała się w zakresie od 296,2 do 978,6 mg · kg⁻¹, miedzi od 6,1 do 25,7 mg · kg⁻¹ i cynku od 29,5 do 99,8 mg · kg⁻¹ gleby. W okresie doświadczalnym 1982–1998 zmniejszyły się całkowite zawartości Mn (o 7,9 %) i Zn (o 3,6 %), jednak nie były to różnice statystycznie istotne (p < 0,05). Całkowite zawartości miedzi w glebie w ciągu 17 lat trwania doświadczenia wzrosły o 7 %. Stwierdzono, że zawartości wszystkich badanych mikroelementów w rejonach uprawy buraka były wyższe niż w rejonach uprawy ziemniaka. Największą, statystycznie istotną różnicę (p < 0,001) zaobserwowano w przypadku miedzi (wzrost o 45,6 %). Biorąc pod uwagę rodzaj gleby, najniższe zawartości Mn i Cu zarejestrowano w glebie lekkiej. Natomiast całkowite zawartości cynku były porównywalne w glebach lekkiej i średniej. Wraz ze wzrostem udziału frakcji ilastych w składzie granulometrycznym gleby znacząco (p < 0,001) wzrastała w badanych glebach zawartość mikroelementów. W porównaniu z glebami lekkimi w glebach ciężkich zawartości metali wzrosły: Mn o 38,9 %, Cu o 48,2 % i Zn o 19,4 %. Zawartości Cu i Zn zależały od typu gleby. Statystycznie (p < 0,001) najwyższy poziom tych mikroelementów stwierdzono w czarnoziemiu (odpowiednio 24,6 i 71,7 mg · kg⁻¹ gleby). Najwyższą zawartość manganu stwierdzono w glebach brunatnych (714,3 mg · kg⁻¹ gleby). Wzrastające dawki nawozów nie miały istotnego wpływu (p < 0,05) na całkowite zawartości metali w glebach. Różnice zaznaczyły się wyraźniej w wariantach, w których nie stosowano wapnowania; w tym przypadku zaobserwowano największe spadki zawartości Mn, Cu i Zn, odpowiednio o 7,3, 23,8 i 9,4 % w porównaniu z obiektem kontrolnym.

Słowa kluczowe: wieloletnie doświadczenie, cynk, mangan i miedź, całkowite zawartości

Krystyna PRZYBULEWSKA¹, Sylwia MICHAŁOWSKA¹,
Magdalena BŁASZAK¹ and Anna STOLARSKA²

GROWTH OF SOIL FUNGI ON CULTURE MEDIA CONTAMINATED WITH SELECTED HERBICIDES

WZROST WYBRANYCH GRZYBÓW GLEBOWYCH NA PODŁOŻACH ZANIECZYSZCZONYCH WYBRANYMI HERBICYDAMI

Abstract: The study aimed at showing the effect of culture media contaminated with triazine herbicides and urea herbicide on the growth of selected soil fungi. Contamination of culture medium with Gesaprim 500 WP, Gesatop 50 WP, Gesagard 50 WP and Ustilan 70 WP herbicides has a significant effect on the growth of soil fungi examined. The magnitude of this effect depends on the quantity of introduced active ingredient contained in preparations and the species of soil fungi. Both stimulation and inhibition of the growth of surface mycelia was observed. Fungi of some species of the genus *Penicillium* as well as *Alternaria* sp., *Fusarium* sp., *Trichotecium roseum*, *Trichocladium asperum* and *Trichoderma* sp. were most resistant to active ingredients contained in the herbicides under discussion, whereas *Penicillium claviforme* and *Mucor* sp. proved to be most sensitive to contamination of culture medium with herbicides.

Keywords: fungi, herbicides, contamination

Chemical substances introduced into soil in result of human activity are not meaningless for soil microflora [1–5]. Most frequently, these compounds are pesticides that are being used to reduce the occurrence of agrophages and to improve crop quantity and quality. Predominant position among them is taken by herbicides which constitute over 50 % of all crop protection chemicals used. Introduction of these chemicals into soil may have a remarkable effect on development of soil microflora, inhibiting or stimulating its growth and metabolic activity. Some substances may be a source of carbon or nitrogen for it, contributing to its growth.

There are many microorganisms known to live in environments that are heavily contaminated with crop protection chemicals [6–9]. Preparations being used in an

¹ Department of Microbiology and Biotechnology of Environment, West Pomeranian University of Technology, ul. J. Słowackiego 17, 71–434 Szczecin, Poland, phone: +48 91 449 64 24, email: krystyna.przybulewska@zut.edu.pl

² Department Plant Physiology, West Pomeranian University of Technology, ul. J. Słowackiego 17, 71–434 Szczecin, Poland.

uncontrolled manner in last years which can be retained for a long-time and then withdrawn from use and stored in tanks from which they can penetrate into soil and groundwater are unusually dangerous [10–13]. This generates a necessity of searching for standardised researches and evaluation criteria of harmfulness for such chemical compounds and their susceptibility to biodegradation [14].

The study aimed at determination of the growth of soil fungi on culture media heavily contaminated with selected herbicides.

Material and methods

In the experiment were used soil fungi cultures from the collection of the Department of Microbiology and Biotechnology of Environment, West Pomeranian University of Technology in Szczecin. In total, 12 different types and species were used, ie *Aspergillus niger*, *Penicillium claviforme*, *Alternaria* sp., *Penicillium* sp. (1), *Mucor* sp., *Trichotecium roseum*, *Penicillium allii*, *Penicillium* sp. (2), *Trichocladium asperum*, *Fusarium* sp., *Peaciliomyces* sp. and *Trichoderma* sp., which were point inoculated on solid culture medium. Different herbicide quantities were introduced into a Martin medium [15], receiving the following doses: 1, 10, 100, 1000, and 10000 mg · dm⁻³. The control was culture medium with no herbicide addition. In the experiment were used herbicides belonging to two groups. The first group was triazine herbicides with an active ingredient in the form of atrazine (Gesaprim 500 WP), simazine (Gesatop 50 WP), prometrine (Gesagard 50 WP), whereas the other one was urea herbicides (Ustilan 70 WP). All herbicides were within Toxicity Class IV. Triazine preparations contained 50 % of active ingredient, with a recommended dose per 1 hectare being 10 dm³ or kg depending on the ingredient from. All these herbicides were a make of Novartis Crop Protection AG, Switzerland, whereas Ustilan 70WP, belonging to urea herbicides containing ethidimuron as an active ingredient, was a product of Bayer France Phytochim. The dose recommended by manufacturer for the latter is 10 kg · ha⁻¹.

Culture incubation was carried out at 25 °C. For 7 days, measurements of the growing colony were made (diameter, in cm).

Statistical analysis of the received results was made by calculating analysis of variance, with significance of differences being calculated with Duncan's test at $p = 0.05$.

Results and discussion

The examined fungi were characterised by varied growth on the control medium without herbicide addition, with mycelium diameter ranging 1.4–6.9 cm. The largest growth was observed in case of fungi *Mucor* sp. (on average 5.8 cm) and *Trichoderma* sp. (on average 6.9 cm), whereas the least one in a fungi identified as *Penicillium claviforme* (on average 1.4 cm).

Based on the statistical analysis carried out, significant differences were found in the growth of surface mycelium after introduction of different herbicides into culture medium (Table 1).

Table 1

The effect of herbicides on the growth of surface mycelium [cm]

Fungus	Dose of herbicide [mg · dm ⁻³]					
	LSD _{0.05}	Control	10	100	1000	10 000
Gesatop 50 WP						
<i>Aspergillus niger</i>	0.744	4.1	4.1	3.5	5.3	0.8
<i>Penicillium claviforme</i>	0.198	1.7	2.0	1.8	1.4	0.1
<i>Alternaria</i> sp.	0.906	2.4	1.1	2.4	3.4	1.1
<i>Penicillium</i> sp. (1)	0.797	3.4	4.0	3.7	4.8	1.1
<i>Mucor</i> sp.	1.276	7.2	6.3	6.8	8.0	0.6
<i>Trichotecium roseum</i>	0.501	4.8	5.4	4.4	8.0	1.3
<i>Penicillium allii</i>	0.415	3.1	3.2	3.5	3.2	2.6
<i>Penicillium</i> sp. (2)	0.697	2.8	2.6	2.8	3.1	1.4
<i>Trichocladium asperum</i>	0.191	2.0	2.0	1.9	1.8	1.0
<i>Fusarium</i> sp.	1.117	1.9	2.1	2.4	1.5	0.8
<i>Peacilliomycetes</i> sp.	1.288	4.1	3.8	4.1	4.0	1.7
<i>Trichoderma</i> sp.	1.918	6.7	6.7	6.1	5.4	5.2
Ustilan 70 WP						
<i>Aspergillus niger</i>	0.916	2.2	2.0	2.0	2.5	0.1
<i>Penicillium claviforme</i>	0.245	0.8	0.8	0.9	0.4	0.1
<i>Alternaria</i> sp.	0.335	1.5	1.4	1.5	1.4	0.4
<i>Penicillium</i> sp. (1)	0.913	2.7	2.3	2.3	1.7	0.5
<i>Mucor</i> sp.	0.602	4.0	3.5	3.2	3.3	1.2
<i>Trichotecium roseum</i>	0.506	3.7	3.5	3.3	0.9	0.1
<i>Penicillium allii</i>	0.237	1.6	1.7	1.8	1.5	0.2
<i>Penicillium</i> sp. (2)	0.157	1.7	1.5	1.5	2.1	0.3
<i>Trichocladium asperum</i>	0.216	1.2	1.1	1.0	0.9	0.2
<i>Fusarium</i> sp.	0.311	1.2	1.3	1.4	1.0	0.2
<i>Peacilliomycetes</i> sp.	0.645	2.3	1.9	1.8	2.0	0.2
<i>Trichoderma</i> sp.	2.094	6.1	6.8	4.4	6.8	0.3
Gesaprim 500 WP						
<i>Aspergillus niger</i>	1.159	5.2	4.0	4.2	3.4	1.8
<i>Penicillium claviforme</i>	0.319	1.9	1.7	2.0	0.9	0.5
<i>Alternaria</i> sp.	0.810	2.4	2.6	2.8	2.5	1.5
<i>Penicillium</i> sp. (1)	1.186	3.5	4.2	3.4	3.3	1.5
<i>Mucor</i> sp.	1.634	6.8	6.7	5.3	4.3	1.7
<i>Trichotecium roseum</i>	0.396	5.5	4.7	5.4	4.0	3.0
<i>Penicillium allii</i>	1.155	3.9	3.1	3.0	2.8	1.6
<i>Penicillium</i> sp. (2)	1.296	2.6	3.0	3.0	2.9	1.6
<i>Trichocladium asperum</i>	0.562	2.1	2.0	2.0	1.5	1.5
<i>Fusarium</i> sp.	1.199	2.0	2.3	4.4	1.8	0.6
<i>Peacilliomycetes</i> sp.	1.471	5.1	4.9	4.4	4.5	1.8
<i>Trichoderma</i> sp.	0.824	8.3	8.0	8.8	4.9	2.7

Table 1 contd.

Fungus	Dose of herbicide [mg · dm ⁻³]					
	LSD _{0.05}	Control	10	100	1000	10 000
Gesagard 50 WP						
<i>Aspergillus niger</i>	1.418	3.3	4.0	3.1	2.3	0.5
<i>Penicillium claviforme</i>	0.210	1.3	1.1	1.4	0.7	0.1
<i>Alternaria</i> sp.	1.089	2.1	2.2	2.5	3.0	1.8
<i>Penicillium</i> sp. (1)	0.721	2.8	4.7	3.2	2.7	1.0
<i>Mucor</i> sp.	0.545	5.2	8.1	4.2	4.5	0.5
<i>Trichotecium roseum</i>	1.507	5.1	6.3	3.8	3.1	1.3
<i>Penicillium allii</i>	1.974	3.8	2.3	3.9	3.2	1.5
<i>Penicillium</i> sp. (2)	1.292	3.6	2.5	3.3	3.0	1.4
<i>Trichocladium asperum</i>	0.436	2.0	1.3	1.5	1.4	1.0
<i>Fusarium</i> sp.	0.968	2.9	1.2	2.0	1.0	0.6
<i>Peacilliomyces</i> sp.	0.904	3.1	3.7	2.4	3.4	0.9
<i>Trichoderma</i> sp.	0.770	6.5	8.1	5.1	3.4	1.3

In certain soil fungi, eg of the genus *Penicillium* (strain 1), *Penicillium claviforme*, *Fusarium* sp., *Trichotecium roseum* and *Penicillium allii*, addition of Gesatop 50 WP preparation to culture medium in a dose contaminating it even considerably (1000 mg · dm⁻³) stimulated the growth of surface mycelium, on average from several to even few dozen percent in relation to the control. In case of other fungi, a slight inhibition of growth was observed – from a few to several percent, whereas in case of *Alternaria* sp. a twice smaller growth was observed in relation to the control. The highest contamination with simazine-containing preparation in culture medium (10000 mg · dm⁻³) induced a significant inhibition of the growth of all fungi, in particular of *Penicillium claviforme* and *Mucor* sp. The largest resistance to such a high contamination with the herbicide under discussion was demonstrated by fungi *Trichoderma* sp. and *Penicillium allii*. Jaworska and Dłuzniewska [3] demonstrated in their study that herbicides had an effect on the growth and biological activity of fungi *Trichoderma harzianum* and *Trichoderma viride* but changes depended on the type of preparation and its concentration as well as fungus isolate. Nowak [16] reported intensification of the growth inhibition in a colony of *Trichoderma* spp. Wachowska [4] observed that herbicide Roundup tested under *in vitro* conditions demonstrated fungistatic activity in relation to *Trichoderma hamatum*, inhibiting the colony growth by 38 %. The varied effect of herbicides on the growth of *Trichoderma viride* was also observed by Klimach and Wiczorek [1].

Addition of herbicide Gesaprim 500 WP to culture medium also induced significant differences in the growth of surface mycelium of the fungi under examination (Table 1). In case of fungi *Alternaria* sp., *Penicillium* sp. (strain 1 and strain 2) as well as *Fusarium* sp., several percent stimulations were observed as affected by the presence of this herbicide in culture medium. The remaining fungi responded unfavourably, the result of which was smaller mycelium diameter. This effect was most visible after application of the highest contamination with herbicide Gesaprim 500WP.

In fungi such as *Aspergillus niger*, *Penicillium* sp. (strain 1), *Mucor* sp., *Trichotecium roseum* and *Peaciliomyces* sp., a stimulation of surface mycelium was observed as affected by an active ingredient contained in Gesagard 50 WP preparation added to culture medium in a least dose ($10 \text{ mg} \cdot \text{dm}^{-3}$ of medium), on average by over 30 % in relation to the control. Larger concentration of active ingredient, a 10- and 100-fold one, stimulated only the growth of mycelium in *Alternaria* sp., *Penicillium* sp. (strain 1) and *Peacilliomyces* sp. in culture medium containing $1000 \text{ mg} \cdot \text{dm}^{-3}$ of active ingredient. The increase of contamination with this herbicide induced clear reduction in the growth of fungi, on average by almost 70 % when compared with the control.

The addition of herbicide Ustilan 70 WP induced significant differences in the growth of fungi, which also depended on the value of herbicide concentration in culture medium (Table 1). Introduction of this xenobiotic to a concentration of $1000 \text{ mg} \cdot \text{dm}^{-3}$ of culture medium induced stimulation of the growth of surface mycelium in some fungi, on average by several percent. An exception was fungi identified as *Penicillium* sp. (strain 1), *Mucor* sp., *Trichtecium roseum*, *Trichocladium asperum* and *Peacilliomyces* sp., in which inhibition of growth was observed in relation to the control, on average by over 30 %. Application of a ten-fold higher concentration of herbicide significantly decreased the growth of all fungi.

When analysing the results of experiment with herbicides Gesaprim 500 WP, Gesatop 50 WP, Gesagard 50 WP and Ustilan 70 WP, a tendency was observed for the growth of some surface mycelia on solid culture media with smaller quantity of active ingredient contained in the preparation under examination which depended on the introduced dose. Most frequently observed stimulation was found in fungi as affected by herbicides Gesatop 50 WP and Gesaprim 500WP, while a smaller one in result of introduction of Ustilan 70 WP preparation. After introduction of larger herbicide concentrations, a clear inhibition of the growth of surface mycelium was observed. The strongest inhibition of mycelium growth was observed after addition of herbicide Ustilan 70 WP and herbicide Gesagard 50WP. The smallest inhibition of growth was found in result of the effect of active ingredient contained in Gesatop 50 WP preparation.

The fungi most resistant to active ingredients contained in the herbicides discussed above were as follows: *Penicillium* sp. (strain 1) and *Penicillium allii*, *Alternaria* sp., *Fusarium* sp., *Trichotecium roseum*, *Trichocladium asperum* and *Trichoderma* sp. in culture medium contaminated with Gesatop 50 WP preparation. The fungus most sensitive to contamination of culture medium with the herbicides under discussion proved to be *Penicillium claviforme* and also frequently *Mucor* sp.

Most herbicides in small doses had no significant effect on the growth and development of fungi and other soil microorganisms, whereas a varied response of these microorganisms was observed after application of larger doses of preparation consisting in inhibition or stimulation of their growth and proliferation [5, 17–20].

Conclusions

Contamination of culture medium with herbicides Gesaprim 500 WP, Gesatop 50 WP, Gesagard 50 WP and Ustilan 70 WP had a significant effect on the growth of the

soil fungi under examination. The magnitude of this effect depends on the quantity of introduced active ingredient contained in preparations and the type or species of soil fungi. On solid culture media with addition of the smallest quantity of active ingredient from preparations Gesatop 50 WP and Gesaprim 500 WP a tendency was observed for the growth of some surface mycelia and a considerably smaller stimulation in result of introduction of Ustilan 70 WP preparation. The strongest inhibition of mycelium growth was observed after addition of herbicide Ustilan 70 WP and herbicide Gesagard 50WP. The smallest inhibition of growth was found in result of the effect of active ingredient contained in Gesatop 50 WP preparation.

The fungi most resistant to active ingredients contained in the herbicides discussed above were those of the genus *Penicillium* strain 1 and *Penicillium allii*, *Alternaria*, *Fusarium*, *Trichotecium roseum*, *Trichocladium asperum* and *Trichoderma* sp. in culture medium contaminated with Gesatop 50 WP preparation. The fungus most sensitive to contamination of culture medium with the herbicides under discussion proved to be *Penicillium claviforme* and also frequently *Mucor* sp.

References

- [1] Klimach A. and Wieczorek W.: *Ocena wpływu kilku środków ochrony roślin na wybrane organizmy glebowe*, Progr. Plant Protect. 1998, **38**(2), 587–589.
- [2] Jaworska M. and Dłużniewska J.: *Aktywność in vitro wybranych herbicydów w stosunku do grzybów z rodzaju Trichoderma*, Progr. Plant Protect. 2002, **42**(2), 633–635.
- [3] Jaworska M. and Dłużniewska J.: *Wpływ wybranych herbicydów na wzrost i aktywność biologiczną Trichoderma spp.*, Progr. Plant Protect. 2003, **43**(2), 704–707.
- [4] Wachowska U.: *Effect of glyphosate on the growth and sporulation of several fungi species grown in vitro. Oddziaływanie herbicydu Roundup na wzrost i zarodnikowanie kilku gatunków grzybów w warunkach in vitro*, Acta Mycol. 1998, **33**(1), 155–160.
- [5] Przybulewska K., Nowak A. and Jaworska A.: *The influence of herbicides on the microorganisms count and activity in soil*, Polish J. Natur. Sc. 2003, **15**(3), 661–669.
- [6] Chlebowski S.: *Mikrobiologiczny rozkład pestycydów w glebie*. Aura 1992, (3), 14–15.
- [7] Sadowski J.: *Badania pozostałości i zachowania się herbicydów w środowisku jako element nowoczesnej ochrony roślin*, Progr. Plant Protect. 2000, **40**(1), 254–258.
- [8] Kapsa J.: *Nasilenie występowania form grzyba Phytophthora infestans odpornych na feniloamidy w latach 1989–1991*, Ochr. Rośl. 1992, **5**, 6–8.
- [9] Kapsa J., Lewosz W., Osowski J. and Gawińska H.: *Występowanie w Polsce odpornych na feniloamidy form grzyba Phytophthora infestans*, Progr. Plant Protect. 1999, **39**(1), 109–115.
- [10] Domsch K.H.: *Pestizide im Boden, Mikrobieller Abbau und Nebenwirkungen auf Mikroorganismen*, VCH Weinheim, New York, Basel, Cambridge 1992, pp. 575.
- [11] Dąbrowski J., Walorczyk S., Drożdżyński D. and Nowacka A.: *Badanie pozostałości atrazyny i symazyny oraz ich metabolitów w wodach podziemnych woj. poznańskiego w latach 1996–1997*, Progr. Plant Protect. 1998, **38**(2), 595–597.
- [12] Getenga Z. M.: *Enhanced mineralization of atrazine in compost-amended soil in laboratory studies*, Bull. Environ. Contam. Toxicol. 2003, **71**, 933–941.
- [13] Marecik R., Króliczak P. and Czaczyk K.: *Rozkład atrazyny przy udziale beztlenowych mikroorganizmów glebowych*, Post. Mikrobiol. 2004, **47**, Supl. 1, 472.
- [14] Dąbrowski J., Gąsior J., Janda T., Krause A., Morzycka B., Murawska M., Sadło S., Barylska E., Gierschendorf Z., Giza I., Langowska B., Martinek M., Michel M. and Rupar J.: *Obraz skażeń pozostałościami pestycydów upraw rolnych i gleb w Polsce w latach 1991–1995*, Progr. Plant Protect. 1996, **36**(1), 57–76.
- [15] Martin J.P.: *Use of acid, rose bengals and streptomycin in the plate method for estimating soil fungi*. Soil Sci. 1950, 215–233.

- [16] Nowak A.: *Wpływ stężenia pożywki oraz pH na działanie wywierane przez Afalon na wzrost *Treichoderma* sp. w hodowlach in vitro*, Phytopathologia Polonica 1990, **11**, 25–31.
- [17] Ganesan T. and Lalithakumari D.: *Interaction of carbendazim with herbicide and insecticide and their influence on soil microorganisms*. J. Ecobiol. 1990, **2**(4), 319–324.
- [18] Cernakova M., Kurcova M. and Fuchsova D.: *Effect of the herbicide Bentanex on soil microorganisms and their activity*. Folia Microbiol. 1991, **36**, 561–566.
- [19] Chauhan U.K., Mahindra A. and Suryanarayana V.: *Influence of pesticide on soil microflora*, J. Ecotoxicol. Environ. Monit. 1994, **4**(2), 133–136.
- [20] Danderski W., Kampert M., Lalke E. and Bryk M.: *Effect of atrazine on occurrence of different groups of microorganisms in soil of apple orchard*, Fruit Sci. Rep. 1992, **19**(2), 79–88.

WZROST WYBRANYCH GRZYBÓW GLEBOWYCH NA PODŁOŻACH ZANIECZYSZCZONYCH WYBRANYMI HERBICYDAMI

Katedra Mikrobiologii i Biotechnologii Środowiska
Zachodniopomorski Uniwersytet Technologiczny w Szczecinie

Abstrakt: Celem badań było wykazanie wpływu zanieczyszczenia herbicydami triazynowymi oraz herbicydem mocznikowym podłoża hodowlanych na wzrost wybranych grzybów glebowych. Zanieczyszczenie podłoża herbicydami Gesaprim 500 WP, Gesatop 50 WP, Gesagard 50 WP i Ustilan 70 WP wpływa znacznie na wzrost badanych grzybów glebowych. Wielkość tego wpływu zależy o ilości wprowadzonej substancji aktywnej zawartej w preparatach oraz rodzaju czy gatunku grzybów glebowych. Stwierdzono zarówno stymulacje, jak i hamowanie wzrostu grzybni powierzchniowych. Do najbardziej odpornych grzybów na substancje aktywne zawarte w powyżej omawianych herbicydach były grzyby z niektórych gatunków z rodzaju *Penicillium*, a także *Alternaria* sp., *Fusarium* sp., *Trichotecium roseum*, *Trichocladium asperum* oraz *Trichoderma* sp. Najbardziej wrażliwym grzybem na zanieczyszczenie podłoża omawianymi herbicydami okazał się *Penicillium claviforme* i *Mucor* sp.

Słowa kluczowe: grzyby, herbicydy, zanieczyszczenie

Agata ŚWIECİŁO¹

**EFFECT OF PESTICIDE PREPARATIONS
AND INDOLEACETIC ACID
ON YEAST *Saccharomyces cerevisiae* CELLS**

**ODDZIAŁYWANIE PREPARATÓW PESTYCYDOWYCH
ORAZ HETEROAUKSYNY
NA KOMÓRKI DROŻDŻY *Saccharomyces cerevisiae***

Abstract: Yeast are often used as a model organism in studies on non-specific effects of xenobiotics. This paper investigates susceptibility of yeast cells of different strains differing in effectiveness of antioxidant system on commercial preparations Betokson Super 025 SL and Fusilade Forte 150 EC which are used as pesticides, and on phytohormone indoleacetic acid (IAA). The experiment was carried out on a wild strain of yeast and mutant *sod1* devoid of cytosolic superoxide dismutase activity, *ctl1ctal* with no catalase activity, and also the mutant C4 with a low level of glutathione. Susceptibility of the cells was estimated upon their ability to grow on solid medium that contained the investigated substances. The results suggest that the enzyme superoxide dismutase plays an important role in protection of yeast cells against the effects of active substances in preparations Fusilade Forte 150 EC, Betokson Super 025 SL and IAA.

Keywords: *Saccharomyces cerevisiae*, antioxidative status, β -naphthoxyacetic acid, fluzifop-*p*-butyl, IAA

Different methodological approaches are used to study of non-specific effects of plant pesticides. One approach focuses on such aspects as assessment of the activity of different physiological groups of microorganisms, which occur in soil environment. Another approach consists in studying the reaction of laboratory strains of microorganisms. This study presents the effect of selected products used in crop protection and phytohormone indoleacetic acid (IAA) on yeast cells *Saccharomyces cerevisiae*. For years they have been used as a model organism in the study of non-specific effect of xenobiotics, such as pesticides, heavy metals and PAHs [1–4]. Contrary to the higher eukaryotes yeast cells tolerate numerous mutations which lead to the change in the activity of their antioxidative system. The *sod1* mutants are devoid of cytoplasmic activity of superoxide dismutase, ie an enzyme which removes superoxide anion-radical

¹ Chair of Biochemistry and Environmental Chemistry, Department of Agricultural Sciences in Zamosc, University of Life Science in Lublin, ul. Szczepiezska 102, 22–400 Zamość, Poland, email: agata.swiecilo@up.lublin.pl

from cytoplasmic space. The cells of *ctt1cta1* mutant are devoid of cytoplasmic activity of T catalase and peroxysomal A catalase, ie enzymes which remove hydrogen peroxide from these cell compartments. The mutant marked with the symbol C4 is distinguished by a level of glutathione (GSH) lowered by 85 % as compared with the level of this tripeptide in isogenic cells of the wild strain. The reaction of these mutants to different environmental factors has already been extensively described [5–8]. They are also used for the purpose of determining the role of the particular elements of the antioxidative system in the mechanisms of toxicity of studied substances. The aim of the presented study was the assessment of the sensitivity of yeast cells with changed efficiency of antioxidative system to such products as Betokson Super 025 SL and Fusilade Forte 150 EC (containing: β -naphthoxyacetic acid (NOA) and fluzapof-*p*-butyl as active substances, respectively) as well as indoleacetic acid IAA.

Material and methods

The following strains of *Saccharomyces cerevisiae* were used in the experiment:

The SP4 wild strain (wt) of genotype Mat α leu1 arg4, the DSCD1-1C strain devoid of the cytoplasmic activity of superoxide dismutase of genotype Mat α leu1 arg4 *sod1*, the A50 strain of genotype Mat α leu1 arg4 *ctt1 cta1*, completely devoid of catalase activity and the C4 strain of genotype Mat α leu1 arg4 *als1* which had a low level of glutathione.

The yeast cells of the above-mentioned strains were grown in liquid medium YPD containing peptone (1 %), yeast extract (1 %) and glucose (2 %) in order to obtain a culture of cells at early stationary stage of growth. The culture was diluted so as to obtain a suspension of the cells of each strain of the same density. Drops of 5 mm³ (μ l) of the suspension of cells whose density was 3×10^5 , 3×10^4 , 3×10^3 and 3×10^2 were used to inoculate solid media containing different concentrations of the preparations under study. The yeast was grown in an incubator for three days in the dark at 28 °C. Then the features of their merged and colony growth were assessed. Noticeable differences in the growth of these cells (poor growth, lack of growth) were accepted as a criterion of their sensitivity. The experiments were documented by means of photographs.

Pesticide preparations, ie Betokson Super 025 SL, Fusilade Forte 150 EC and stock solution of IAA in concentration of 10 mM (in DMSO) were diluted with sterile distilled water and added to the liquidated solid medium in such amounts as to obtain the concentrations of active substances (0.05, 0.1, 0.15, 0.2, 0.3, 0.5 mg \cdot cm⁻³).

The experiment was repeated three times in order to verify the repeatability of the obtained results.

Results and discussion

The sensitivity of cells to the active substances of the preparations under study was determined by the assessment of the growth of cells on solid medium in the presence of these substances. Such conditions of culture provide a possibility for assessment of long-term effects of these substances on yeast cells.

Table 1

Sensitivity of yeast cells of studied strains to IAA, NOA and fluazifop-*p*-butyl

Concentrations of active substances [mg · cm ⁻³]	<i>wt</i>	<i>sod1</i>	<i>cta1cta1</i>	Glutathione-poor mutant
0 (control)	+	+	+	+
IAA				
0.15	+	+	+	+
0.2	+	+/-	+	+
0.25	+	+/-	+	+
0.3	+	+/-	+	+
0.5	+	+/-	+	+
NOA				
0.1	+	+	+	+
0.15	+	+	+	+
0.2	+	+	+	+
0.3	+	+	+	+
0.5	+	+/-	+	+
Fluazifop- <i>p</i> -butyl				
0.015	+	+	+	+
0.1	+	+	+	+
0.15	+	+	+	+
0.2	+	+	+	+
0.3	+	+	+	+
0.5	+/-	—	+/-	+/-

+ – means the intensity of growth comparable to that in the control; — – means lack of growth; +/- – means poorer growth as compared with that in the control.

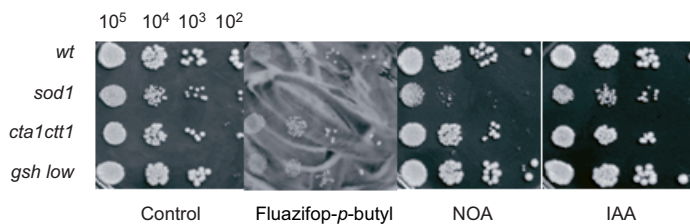

Fig. 1. Growth of yeast cells in the presence of 0.5 mg · cm⁻³ IAA, NOA and fluazifop-*p*-butyl – active substances of Betokson Super 025 SL and Fusilade Forte 150 EC preparations

After a suitable amount of emulsion of Fusilade Forte 150 EC preparation was added to YPD media, it became turbid.

Yeast cells of the wild strain and the C4 and *cta1cta1* mutants proved to be resistant to the used concentration of indoleacetic acid. Only the cells of the *sod1* mutant manifested sensitivity to higher concentrations of this substance. These strains reacted

in a similar way to the presence of Betokson Super 025 SL preparation. In the case of Fusilade Forte 150 EC preparation clear differences in the growth of the cells of all studied strains were observed after the preparation was applied in the highest concentration ($0.5 \text{ mg} \cdot \text{cm}^{-3}$ as converted into the content of the active substance). The cells of the *sod1* mutant proved to be the most sensitive to the effect of this factor; in these conditions these cells were not able to grow at all. The growth of the cells of the remaining strains under study was very poor: there were small colonies at the place of sowing.

The obtained results suggest that IAA and the synthetic derivative of this hormone – NOA, used as a stimulator of tomato fruit setting, do not have cytostatic properties with respect to the cells of wild strains and such mutants as *ctt1cta1* and C4. According to the data presented in a study by Prusty et al [9], IAA (but not other compounds which have a similar chemical structure) may have different effect on the *Saccharomyces cerevisiae* yeast, depending on the dose used. At low concentrations it enhances both haploid invasion and diploid pseudohyphal growth of yeast cells. Such reaction provides a possibility for infection of the plant by pathogenic yeast strains. When IAA was used at high concentrations inhibition of the growth of yeast of the wild strain was observed both on liquid medium ($EC_{50} = 250 \text{ } \mu\text{M}$) and on solid medium. In view of the fact that these authors used a different method of assessment of the sensitivity of yeast cells grown on solid medium to IAA, a direct comparison of the obtained results is impossible. According to these authors, the *yap1a* strain, devoid of the activity of Yap1p transcription factor which acts as an agent in reaction of yeast cells to pro-oxidative substances, manifested over sensitivity to IAA. According to the present study the *sod1* mutant, devoid of superoxide dismutase – a key enzyme of antioxidative defence, manifested the strongest reaction to IAA.

Fusilade Forte 150 EC containing fluazifop-*p*-butyl used in the highest concentration ($0.5 \text{ mg} \cdot \text{cm}^{-3}$) manifested strong cytostatic effect with respect to the cells of the wild strain and the *ctt1cta1* and C4 mutants; it had a cytotoxic effect on the *sod1* mutant. Consequently, the activity of dismutase is a significant element of the antioxidative system of yeast and it is necessary in order to protect the yeast against the toxic effect induced by this herbicide. As proved in specialist literature, the cells of the *sod1* mutant are also characterised by over sensitivity to many other environmental factors, such as the presence of sodium nitrate(III), iron salts and the atmosphere containing 100 % oxygen [6, 10, 11].

As shown by the result obtained in this study catalase activity and concentration of low-molecular antioxidant GSH play a supporting part in the system of defence of cells against cytostatic effect of Fusilade Forte 150 EC preparation. It probably results from compensatory abilities of yeast consisting in inducing alternative defence and repair mechanisms, such as a response to oxidative stress [12].

Conclusions

1. Fusilade Forte 150 EC herbicide has a cytostatic effect on the yeast cells of the wild strain the *ctt1cta1* and C4 mutants and a cytotoxic effect on the *sod1* mutant.
2. IAA and Betokson Super 025 SL have cytostatic effect only on the *sod1* mutant.

3. Activity of cytoplasmic superoxide dismutase plays a key role in the protection of yeast cells from harmful effects induced by Fusilade Forte 150 EC, Betokson Super 025 SL preparations and phytohormone IAA.

References

- [1] Krzepińko A. and Świącilo A.: *The effect of selected pyrethroids on the total antioxidant capacity of yeast cell extracts*, Polish J. Environ. Stud. 2007, **16**(3A), 170–173.
- [2] Chen C. and Wang J.L.: *Characteristics of Zn²⁺ biosorption by Saccharomyces cerevisiae*, Biomed. Environ. Sci. 2007, **20**(6), 478–482.
- [3] Frazzoli C., Dragone R., Mantovani A., Massimi C. and Campanella L.: *Functional toxicity and tolerance patterns of bioavailable Pd(II), Pt(II), and Rh(III) on suspended Saccharomyces cerevisiae cells assayed in tandem by a respirometric biosensor*, Anal Bioanal. Chem. 2007, **389**(7–8), 2185–2194.
- [4] Alnafisi A., Hughes J., Wang G. and Miller C.A.: *Evaluating polycyclic aromatic hydrocarbons using a yeast bioassay*, Environ. Toxicol. Chem. 2007, **26**(7), 1333–1339.
- [5] Park Jong-In., Grant Chris M., Davies M.J. and Dawes Ian W.: *The Cytoplasmic Cu, Zn Superoxide Dismutase of Saccharomyces cerevisiae is required for resistance to freeze-thaw stress*, J. Biol. Chem. **273**(36), 22921–22928.
- [6] Wawryn J., Krzepińko A., Myszk A. and Biliński T.: *Deficiency in superoxide dismutases shortens life span of yeast cells*, Acta Biochim. Polon. 1999, **46**(2), 249–253.
- [7] Świącilo A. and Krzepińko A.: *The role of antioxidant system in response of yeast Saccharomyces cerevisiae cells to strong salt stress*, Zesz. Probl. Post. Nauk Roln. 2005, **505**, 451–458 (in Polish).
- [8] Krzepińko A.: *Effect of deltamethrin on the antioxidant system of Saccharomyces cerevisiae yeast*, Ecol. Chem. Eng. 2007, **14**(2), 191–196.
- [9] Prusty R., Grisafi P. and Fink G.R.: *The plant hormone indoleacetic acid induces invasive growth in Saccharomyces cerevisiae*, Proc. Natl Acad. Sci. USA 2004, **101**(12), 4153–4157.
- [10] Świącilo A. and Krzepińko A.: *The role of antioxidant status and energetic metabolism in the response of yeast cells to sodium nitrate(III)*, Polish J. Environ. Stud. 2007, **16**(3A), 268–272.
- [11] Wiśnicka R., Krzepińko A., Wawryn J. and Biliński T.: *Iron toxicity in yeast*, Acta Microbiol. Polon. 1997, **46**(4), 339–347.
- [12] Jaruga E., Lapshina E.A., Biliński T., Płonka A. and Bartosz G.: *Resistance to ionizing radiation and antioxidative defence in yeasts. Are antioxidant-deficient cells permanently stressed?* Biochem. Mol. Biol. Int. 1995, **37**(3), 467–473.

ODDZIAŁYWANIE PREPARATÓW PESTYCYDOWYCH ORAZ HETEROAUKSYNY NA KOMÓRKI DROŻDŻY *Saccharomyces cerevisiae*

Katedra Biochemii i Chemii Środowiskowej
Uniwersytet Przyrodniczy w Lublinie

Abstrakt: Drożdże są często wykorzystywane jako organizm modelowy w badaniach nad niespecyficznym oddziaływaniem ksenobiotyków. W przedstawionej pracy badano wrażliwość komórek drożdży szczepów różniących się sprawnością systemu antyoksydacyjnego na handlowe preparaty: Betokson Super 025 SL i Fusilade Forte 150 EC stosowane jako środki ochrony roślin oraz na fitohormon heteroauksynę IAA. Doświadczenia przeprowadzono na szczepie dzikim drożdży, mutancie *sod1* pozbawionym aktywności cytoplazmatycznej dysmutazy ponadtlenkowej, mutancie *ctl1cta1* pozbawionym całkowicie aktywności katalazowej oraz mutancie C4 o niskim poziomie glutationu. Wrażliwość tych komórek oceniano na podstawie ich zdolności do wzrostu na pożywce stałej zawierającej badane substancje. Uzyskane wyniki sugerują, że enzym dysmutaza ponadtlenkowa odgrywa ważną rolę w ochronie komórek drożdży przed szkodliwym działaniem substancji czynnych preparatów Fusilade Forte 150 EC i Betokson Super 025 SL oraz fitohormonu IAA.

Słowa kluczowe: *Saccharomyces cerevisiae*, system antyoksydacyjny, kwas β-naftoksyoctowy, flauazyfop-*p*-butyloowy, auksyna

Alina KOWALCZYK-JUŚKO¹

PROPERTIES OF ASH IN THE COMBUSTION OF SELECTED ENERGY CROPS

WŁAŚCIWOŚCI POPIOŁU ZE SPALANIA WYBRANYCH GATUNKÓW ROŚLIN ENERGETYCZNYCH

Abstract: Chemical composition and fusibility of ash from three species of perennial plants used as energy crops has been analyzed, two of which are grasses: (*Miscanthus sacchariflorus* and *Spartina pectinata*) and a bifoliolate plant *Sida hermaphrodita*. Ash parameters have been compared from crops harvested after the first and third year of vegetation. The species selected for analysis are highly productive, however they are not commonly used in cultivation, and the awareness of their possible use as energy crops in this country is fairly limited. The research conducted has indicated that *Sida hermaphrodita* is characterized by the lowest ash content. However, the chemical composition of such ash contains the highest concentration of alkali oxides, responsible for deposit formation in the combustion installations. In the case of *Sida hermaphrodita* harvested in the first year, the c_m coefficient amounted to 20.86, and after three years to 16.60, whereas in the case of miscanthus, the values were 0.24 and 0.19 respectively, and for *Spartina pectinata* 0.69 and 0.39 respectively. This indicates a much higher risk of ash deposits in combustion chambers, and a decreased overall efficiency of boilers fuelled by *Sida hermaphrodita* biomass. The highest content of chlorides was found in the ash of *Spartina pectinata* harvested in the first year, whereas they were not found in the case of *Miscanthus sacchariflorus* harvested after three years of vegetation. Additionally, ash resulting from the *Miscanthus sacchariflorus* biomass was characterized by the highest fusibility temperatures.

Keywords: biomass, energy crops, ash, chemical composition, fusibility

Burning biomass is a way of converting solar radiation energy into a fairly convenient and universal form of heat energy. It is also the oldest and apparently simplest way of generating energy. From a chemical point of view, such combustion is a conversion of organic matter into carbon dioxide and water in the presence of oxygen. Biomass can be burnt as homogeneous fuel in boilers adapted for this purpose, or added in various proportions to coal. The biomass co-burning with coal in high output boilers used for commercial energy generation, is regarded as an opportunity to meet requirements imposed on Poland as part of the EU Accession Treaty. The requirements

¹ Department of Agricultural Production and Agrobusiness, University of Life Sciences in Lublin, ul. Szczepińska 102, 22-400 Zamość, Poland, phone: +48 84 677 27 53, fax: +48 84 639 60 39, email: alina.jusko@up.lublin.pl

describe targets that are to be met by the proportion of electrical energy generated from renewable sources in the total consumption of electrical energy. Large generation facilities (such as power plants and heat generation plants) require vast amounts of biomass characterized by constant quality, low price and economically justifiable distance from the source of its production. The product that meets such criteria and that can be used in the co-burning process with coal is wood produced in forests and dedicated cultivation, as well industrial wood waste materials [1].

The constant contraction of biomass supplies originating from forestry and wood manufacturing, coupled with legislation requiring the gradual replacement of wood used in energy generation by biomass coming from other sources have meant an increased interest in the cultivation of crops with a high production potential. In this context, we can mention the highly productive energy crops of perennial grasses, and other perennial species such as bushes and trees with a short production cycle, spanning from a few to several years [2]. The country's legislation governing subsidies to energy crops point to many species that can actually be used in biomass energy generation. At the same time, there is a lack of definite, precise and reliable agro-technical guidelines for many of the crops, as well as specifications of such biomass. The research on the properties of biomass as well as on the standardization of research methods on such fuels is carried out by specialized centers such as the European Committee for Standardization CEN/TC 335 Solid Biofuels [3].

A high diversification of biomass in terms of its chemical composition and physical properties causes certain problems in its combustion and emission of pollutants which are a side effect of the process. Therefore, a thorough knowledge of characteristics of biomass coming from various sources is important from the point of view of energy efficiency. The important parameters are not only the crop volume and energy value, but also ash content, which is left as waste in the combustion of any solid fuel. The ash resulting from burning biomass can actually be used as mineral fertilizer in agriculture [2, 4], but only under the condition that pure biomass has been used in the process. In the case of co-burning with coal or culm, the mineral content of biomass increases the amount of total ash volume, and thus becomes a cumbersome waste product in energy generation industry. The chemical composition of biomass ash is also of importance to the energy generation sector, as the high content of alkali and chemically reactive chloride can cause corrosion to boiler installations and result in deposit formation in convection surfaces [5]. The proportions between the alkaline compounds (Fe_2O_3 , CaO , MgO , Na_2O , K_2O , P_2O_5) and the acidic ones (SiO_2 , Al_2O_3 , TiO_2), which can be found in biomass ash, constitute an index of the susceptibility of such ash to form deposits [6, 7]. For biomass ashes, the index is much higher in comparison with the values for coal, which has adverse effects for the convection surfaces in the boiler, as it leads to the decrease in heat transfer efficiency of such surfaces.

Filipowski [8], although with some degree of simplification, states that a measure for the susceptibility of slagging for a given type of fuel is in fact its fusibility temperature characteristics, defined by four values of temperatures: that of sintering, softening, melting and pouring. Adhesion properties are shown by ashes even in the temperatures between the points of softening and melting. It is also important how the fusibility of

ash changes according to the chemical composition of the fuel: iron, calcium, and sodium compounds lower ash fusibility temperature, whereas silicate and aluminium oxides increase it. In such contexts, the determination of both composition, and ash fusibility temperatures is of paramount importance for the assessment of particular biomass products.

Sciazko et al [9] mention that characteristic ash fusibility temperatures of coal and biomass arrived at in laboratory conditions may not provide sufficient information on possible slagging effects of heat transfer surfaces. This seems to be caused by the following phenomena:

- ash fusibility temperatures are assessed on the basis of the ash contained in the fuel, whereas the actual ash content resulting from burning/co-burning may vary, which results from the adhesive properties of ash elements;
- fusibility temperatures are assessed in a relatively short span of time, whereas the deposits in the boiler are formed throughout extended periods of use, and are subject to alternate processes of heating and cooling in the presence of combustion gases;
- ash fusibility temperatures defined in laboratory conditions do not take into account boiler characteristics and conditions in which it is operated, which ultimately influence the processes of deposit formation and slagging;
- the process of fusibility operates in a different way when samples are subjected to a constant temperature for a given period of time; fusibility temperatures thus defined are bound to be lower.

According to Zamorowski [7] the problem of heat transfer surfaces contamination may in fact be far more complicated, but in any case the resulting effect is always an increase in the temperature of exhaust gases, and consequently – the decrease in the overall efficiency of the boiler, especially in the case of biomass co-burning with coal, in comparison with the efficiency of such installation when only coal-fired. The present research enabled us to compare the chemical composition of ash resulting from biomass combustion of several species of energy crops.

Research methodology

Three species of perennial plants were selected for the research, which, according to the Decree of Minister for Agriculture and Rural Development of March 14, 2008 [10] (Journal of Laws No. 44, item 267), are defined as energy crops. The crops comprised two types of grasses:

- *Miscanthus sacchariflorus* Maxim. (Hack),
- *Spartina pectinata* Link., and
- a bifoliate perennial – *Sida hermaphrodita* (Rusby).

The experiment was set up in May 2003 in the Experimental Station of The Faculty of Agricultural Sciences in Zamosc, Poland, on III class soil in a good wheat complex. The soil was characterized by a neutral pH ($\text{pH}_{\text{KCl}} = 6.6$), the content of phosphorus, potassium and manganese were the following values: 12.3 g P, 16.8 g K and 11.1 g Mg · kg⁻¹, respectively. The experiment was carried out on the total of 18 plots, 6 for each species of crops. Due to a high content of basic macroelements, no additional

mineral or organic fertilizing was applied, and only weeding procedures were carried out. Aboveground parts of the plants were randomly sampled from all plots of particular species. The biomass was harvested twice: after the first and third year of vegetation (2004 and 2006). The samples were analyzed in the Central Laboratory of Power Research and Testing, Company Energopomiar in Gliwice, Poland. Ash content was analyzed in analytic conditions: air dry (A^a) and dry (A^d) using the gravimetric method. Ash, obtained at 600 °C, was analyzed for chemical element composition with the use of a plasma spectrometer ICP OES and using ASCRM-010 as reference. The loss by roasting was determined according to the research standards outlined in PN-77/G-04528/02. The content of particular elements is given in dry state, with the exception of A^a. Characteristic ash fusibility temperatures were determined in semi-reducing atmosphere: sintering temperature t_S °C, softening temperature t_A °C, melting temperature t_B °C, and pouring temperature t_C °C.

Based on the analysis results, the c_m coefficient was calculated, which characterizes ash susceptibility to form deposits, according to the following formula [9]:

$$c_m = \frac{\text{Fe}_2\text{O}_3 + \text{CaO} + \text{MgO} + \text{Na}_2\text{O} + \text{K}_2\text{O} + \text{P}_2\text{O}_5}{\text{SiO}_2 + \text{Al}_2\text{O}_3 + \text{TiO}_2}$$

Result overview and discussion

The crops after the first year of vegetation were characterized by a higher content of ash in comparison with those after three years of vegetation. (Table 1). The least content of ash (in analytic state 2.5 %, in dry state 2.8 %) was shown by aboveground parts of *Sida hermaphrodita* after the third year of vegetation. In the case of grasses, ash content was higher, and was in the range of 5.1–7.1 % for one year vegetation, and 3.5–4.1 % for three-year vegetation.

Table 1

Determination of ash in plant biomass and coefficient c_m

Species	Crop	Ash [%]		Coefficient c _m
		analytic condition A ^a	dry condition A ^d	
<i>Miscanthus sacchariflorus</i>	1 year	6.5	7.1	0.24
	3 year	3.5	3.7	0.19
<i>Spartina pectinata</i>	1 year	5.1	5.9	0.69
	3 year	3.6	4.1	0.39
<i>Sida hermaphrodita</i>	1 year	4.8	5.2	20.86
	3 year	2.5	2.8	16.60

Ash content in coal, according to research by Sciazko et al [9] amounts to 22.2 %, whereas in pine wood chips 0.3 %, beech wood chips 0.8 %, willow biomass 2.2 %. Grzybek et al [11] report that ash content in coal amounts to 12 %, in cereal straw 3–4 %, and in wood chips is even lower, and ranges between 0.6 % and 1.5 %.

Niedziolka i Zuchniarz [12] report that while burning pure biomass, a small amount of ash is produced, estimated at 0.5–12.5 %, whereas its higher content testifies to the pollution of the product. In turn, Wilk [13] determines ash content in wood biomass at 0.3–7.4 %, and in cereal straw at 4.3–10.4 %. In her opinion, there is a slight negative correlation between ash content and energy value of the material, and she calculated the correlation coefficient to be 0.3093, which means that given the increase of ash content in biomass, there will be a decrease in the value of combustion heat. In the light of the above data, we can conclude that the ash content in energy crops under our analysis was not significantly high and did not exceed average values for other biomass fuels.

We found significant variation in ash content of particular species of plants, where there was a characteristic high content of alkali oxides, responsible for lower ash fusibility temperatures in *Sida hermaphrodita* ash (Table 2). A particularly high content of CaO (44.5 %) was observed in *Sida hermaphrodita* ash after the first year of vegetation, and the highest amounts of K₂O were found in three-year-old *Sida hermaphrodita* (14.3 %). Additionally, in ash from burning three-year-old *Sida hermaphrodita* there was a significant amount of MgO (5.34 %), which is also considered to be an alkali oxide. The total presence of alkali oxides in *Sida hermaphrodita* ash is high and indicates a danger for serious deposit formation in boiler installations while burning the biomass of such species. By contrast, the ash from burning grasses was characterized by a much lower content of alkali compounds, with a high presence of silica at the same time. The SiO₂ content in *Miscanthus sacchariflorus* ash was 76.1 % on average, and in *Spartina pectinata* it amounted to 59.35 %. Thanks to that fact, grass ash shows much weaker tendencies to contaminate heat transfer surfaces. Additionally, a higher content of silica was noted in the ash of three-year-old plants in comparison with one-year-old ones, and this regularity was found across all the species under analysis.

Wasilewski [14] compares the content composition of ashes originating in burning coal and willow and beech chips, respectively. In the case of coal, the content of alkali oxides in ash was relatively low and amounted to 2.66 % CaO, 2.98 % K₂O, 0.89 % P₂O₅, whereas in willow chip ash the values were respectively: 44.5 %, 8.51 % and 5.9 %, and for beech chip ash the respective values were 29.6 %, 10.27 % and 2.68 %. In turn, the percentage content of SiO₂ and Al₂O₃, that is oxides which reduce the adverse effects of ash sediments in boiler installations, was a total of 79.46 % for coal, 22.49 % for willow chips, and 34.1 % for beech chips. Also Sciazko et al [9] point to a significantly higher content of acidic compounds in coal ashes (the total of SiO₂ and Al₂O₃ amounted to 79.7 %) when compared with wood ash (16.9 %), straw ash (50.3 %), sludge (31.4 %) and meat and bone meal (5.96 %). Numerous results of analyses carried out by the Central Laboratory of Energopomiar in Gliwice, represented by Wisz and Matwiejew [5] testify to a vast variance in the presence of various elements in biomass ash. For instance, the content of silica in straw ash ranged from 1.57 to 43.70 %, that of calcium oxide from 7.28 to 34.50 %. Ashes from other biomass fuels were also of significantly variant nature.

Based on the proportion between alkali and acidic compounds, the susceptibility of particular species to form deposits was determined. The highest values of c_m coefficient

Table 2

Content of particular chemical elements (in oxide form) in ash of crops under analysis [%]

Element [%]	Symbol	<i>Miscanthus sacchariflorus</i>			<i>Spartina pectinata</i>			<i>Sida hermaphrodita</i>		
		1-year	3-year	average	1-year	3-year	average	1-year	3-year	average
Silicon dioxide	SiO ₂	74.3	77.9	76.10	52.6	66.1	59.35	2.28	3.20	2.74
Iron	Fe ₂ O ₃	0.92	1.33	1.13	0.89	0.98	0.94	0.62	0.76	0.69
Aluminium	Al ₂ O ₃	0.84	2.06	1.45	0.87	0.85	0.86	0.58	0.48	0.53
Manganese	Mn ₃ O ₄	0.07	0.09	0.08	0.05	0.10	0.08	0.06	0.05	0.06
Titanium	TiO ₂	0.05	0.06	0.06	0.05	0.04	0.05	0.03	0.04	0.04
Calcium	CaO	9.83	8.35	9.09	12.9	14.3	13.60	44.5	35.7	40.10
Magnesium	MgO	0.84	0.82	0.83	1.76	2.30	2.03	1.91	5.34	3.63
Sulphur	SO ₃	4.55	2.21	3.38	5.40	4.63	5.02	2.51	2.42	2.47
Phosphorus	P ₂ O ₅	2.20	1.87	2.04	6.19	2.96	4.58	3.80	4.85	4.33
Sodium	Na ₂ O	0.42	0.46	0.44	0.95	0.88	0.92	0.61	0.80	0.71
Potassium	K ₂ O	3.75	2.66	3.21	14.5	4.97	9.74	8.86	14.3	11.58
Barium	BaO	0.02	0.02	0.02	0.05	0.03	0.04	0.04	0.03	0.04
Strontium	StrO	0.03	0.02	0.03	0.03	0.04	0.04	0.15	0.10	0.13
Chlorides	Cl	0.39	n/f	0.20	2.54	0.25	1.40	0.48	0.24	0.36
Loss by roasting	—	0.82	1.26	1.04	0.83	0.70	0.77	32.8	31.0	31.90

were observed in one-year crops of *Sida hermaphrodita* (20.86), whereas they were much lower for grasses, especially after the third year of vegetation: for *Miscanthus sacchariflorus* the value was 0.19 and for *Spartina pectinata* 0.39.

The c_m coefficient for coal ash is 0.241, and in the case of biomass ash its values may be far higher: for wood ash it amounts to 4.886, and for straw ash to 0.980 [15]. It turns out that such values calculated for grasses do not vary from coal values. By contrast, *Sida hermaphrodita* ash shows a high coefficient for deposit formation, exceeding those for straw and wood. That means that the use of biomass originating from this species may be of a limited nature because of sediments formed on convection surfaces of boilers, especially with a high percentage of such biomass being used for co-burning.

A large loss by roasting, resulting from a high content of carbonates, found in *Sida hermaphrodita* ash indicates a significant amount of organic matter, and consequently, not fully combusted carbon in the ash. The results for grass ashes proved that grasses may be far better suited as bio-fuel in this respect.

The highest presence of chlorides, responsible for corrosion to boiler installations, was found in biomass ash of one-year-old *Spartina pectinata* (2.54 %), and in the case of three-year-old *Miscanthus sacchariflorus* no chlorides at all were found. In *Sida hermaphrodita* ash, the chloride content ranged from 0.24 to 0.48 %. In comparison with the data presented by Wisz and Matwiejew [5], the values were not high, as the content of chloride in straw ash was recorded at the values of 9.09–11.20 %. Sciazko et al [9] stress that a high chloride content may lead to increased corrosion and the build-up of aggressive and reactive deposits as a result of direct combustion of biomass.

Table 3

Characteristic fusibility temperature of ash [°C]

Temperature	Symbol	<i>Miscanthus sacchariflorus</i>		<i>Spartina pectinata</i>		<i>Sida hermaphrodita</i>	
		1-year	3-year	1-year	3-year	1-year	3-year
Sintering	t_s °C	760	760	730	730	685	680
Softening	t_A °C	1460	> 1500	870	1060	745	740
Melting	t_B °C	> 1500	> 1500	1170	1210	1420	> 1500
Pouring	t_C °C	> 1500	> 1500	1260	1250	1425	> 1500

Sida hermaphrodita ash was characterized by lowest sintering and softening temperatures (685 and 745 °C, respectively for one-year-old crops, and 680 and 740 °C for three-year-old crops), and the lowest melting and pouring temperatures were shown by *Spartina pectinata* ash (one-year-old: 1170 and 1260 °C, respectively, and three-year-old: 1210 and 1250 °C respectively). A low temperature of melting means that sediments may form on the heat transfer surface of boilers, thus deteriorating heat transfer.

Wasilewski [14] quotes melting temperatures for ash of various biomass materials (in semi-reducing atmosphere) with reference to coal. As it is revealed by research from the Institute for Chemical Processing of Coal Zabrze, Poland, characteristic temperatures for energy purpose coal were the following [°C]: t_s 920, t_A 1230, t_B 1400 and t_C 1420.

For willow chip ashes the respective temperatures were: 830, 1520, 1530 and 1540 °C, for pine wood sawdust: 1090, 1190, 1220, 1290 °C, for two samples of cereal straw: 800–810, 860–900, 1140–1150, 1220–1280 °C. Hamala and Rog [6] distinguish ashes that are easily melted, whose melting temperature t_B measured in reducing atmosphere is lower than 1200 °C, medium fusible with melting temperatures t_B between 1200 and 1350 °C and ashes that are hard to melt, whose melting temperature exceeds 1350 °C. According to Filipowski's evaluation [8], melting temperature lower than 1230–1250 °C is characteristic for types of coal that are susceptible to slagging, whereas types of coal with a low susceptibility show $t_A > 1350$ °C. Adopting the same criteria for evaluating biomass ashes, we can conclude that among all the species under our investigation only *Miscanthus sacchariflorus* meets the criteria for the prevention of slagging of boiler installations.

Conclusions

1. Biomass of particular energy crops shows significant variance, both in terms of ash content and its chemical composition. This variance should be taken into account when planning the use of biomass in boiler facilities, either as the sole fuel or for co-burning with coal.

2. The least advantageous properties for energy generation purposes were exhibited by *Sida hermaphrodita* ash. A disadvantageous proportion between acidic and alkali oxides was found in its chemical composition, which testifies to its susceptibility to form deposits. Ash composition also influences fusibility temperatures, which are also the least favourable in the case of *Sida hermaphrodita*.

3. Among grasses, the variations were favourable for *Miscanthus sacchariflorus*. A higher content of silica, higher fusibility temperatures, absence of chlorides all predispose *Miscanthus sacchariflorus* biomass to be the best energy crop among the ones under investigation.

4. Ash originating from crops in the first year of vegetation exhibited inferior properties in terms of energy generation purposes in comparison with ash of three-year-old crops. Young plants were characterized by a higher content of alkali oxides in their ash and lower fusibility temperatures. This regularity occurred across the three species under investigation.

5. A high variance in composition and characteristics of ash of energy crops, which seems important for energy generating purposes, indicates a need for further research in this field.

Acknowledgement

This paper has been prepared as part of the Research Project: N 310 073 31/3140: "Production and Biomass Use of Selected Energy Crops" financed by the Polish Ministry of Science and Higher Education

References

- [1] Mirowski T.: *Stan wykorzystania biomasy w energetyce zawodowej*. Polityka Energetyczna 2005, **8**, 395–404.

- [2] Kowalczyk-Juško A.: *Źródła biomasy na cele energetyczne*, [in:] Bioenergetyka podkarpacka, Kościak B. (ed.). PWSZ, Jarosław 2007.
- [3] Winnicka G., Tramer A. and Świeca G.: *Badania właściwości biomasy stałej do celów energetycznych*. Karbo 2005, **2**, 141–147.
- [4] Kalembasa D.: *Ilość i skład chemiczny popiołu z biomasy roślin energetycznych*. Acta Agrophys. 2006, **7**(4), 909–914.
- [5] Wisz J. and Matwiejew A.: *Biomasa – badania w laboratorium w aspekcie przydatności do energetycznego spalania*. Energetyka 2005, **9**, 631–636.
- [6] Hamala K. and Róg L.: *Wpływ składu chemicznego i właściwości fizykochemicznych węgla oraz ich popiołów na wskaźniki żużlowania i zanieczyszczenia powierzchni grzewczych kotłów energetycznych*. Pr. Nauk. GIG Górnictwo i Środowisko 2004, **3**, 81–109.
- [7] Zamorowski K.: *Współspalanie biomasy w kotle rusztowym (na przykładzie badanego obiektu)*. Energetyka, 2006, **1**, 41–45.
- [8] Filipowski K.: *Doświadczenia ze stosowania dodatku do węgla przeciwko szlakowaniu PENTOMAG 2550*. Petol – Enviro Polska, Szczyrk 2007.
- [9] Ściążko M., Zuwała J. and Pronobis M.: *Zalety i wady współspalania biomasy w kotłach energetycznych na tle doświadczeń eksploatacyjnych pierwszego roku współspalania biomasy na skalę przemysłową*. Energetyka 2006, **3**, 207–220.
- [10] Rozporządzenie Ministra Rolnictwa i Rozwoju Wsi z dnia 14 marca 2008 r. w sprawie plonów reprezentatywnych roślin energetycznych w 2008 r. (DzU 2008, nr 44, poz. 267).
- [11] Grzybek A., Gradziuk P. and Kowalczyk K.: *Słoma energetyczne paliwo*. Wyd. Wieś Jutra, Warszawa 2001.
- [12] Niedziółka I. and Zuchniarz A.: *Analiza energetyczna wybranych rodzajów biomasy pochodzenia roślinnego*. MOTROL 2006, **8A**, 232–237.
- [13] Wilk B.: *Określenie zależności wartości opalowej od wybranych właściwości fizykochemicznych biomasy*. Mater. Seminar. “Techniki analityczne i procedury badawcze w zastosowaniu do nowych warunkowań prawnych w energetyce”. IChPW, Zabrze 2006.
- [14] Wasilewski R.: *Doświadczenia IChPW w zakresie współspalania biomasy i paliw alternatywnych*. IChPW, Zabrze 2007.
- [15] Pronobis M.: *Zanieczyszczenia i korozja w kotłach rusztowych spalających biomasę*. VII Konf. Nauk.-Techn. “Kotły rusztowe jako jednostki wielopaliwowe”, Polańczyk 2005.

WŁAŚCIWOŚCI POPIOŁU ZE SPALANIA WYBRANYCH GATUNKÓW ROŚLIN ENERGETYCZNYCH

Katedra Produkcji Roślinnej i Agrobiznesu
Uniwersytet Przyrodniczy w Lublinie

Abstrakt: Badano skład chemiczny i topliwosć popiołu ze spalania trzech gatunków wieloletnich roślin, stosowanych jako surowiec energetyczny: dwu traw (miskanta cukrowego i spartiny preriowej) i gatunku dwuliściennego, którym był ślazowiec pensylwański. Porównywano parametry popiołu z roślin zebranych po pierwszym i trzecim roku wegetacji. Gatunki wybrane do badań są wydajne, jednak mało rozpowszechnione w uprawie, a znajomość ich właściwości energetycznych jest w kraju niewielka. Przeprowadzone analizy wykazały, że najmniejszą zawartością popiołu charakteryzowała się biomasa ślazowca pensylwańskiego. Jednak w składzie chemicznym popiołu ślazowca stwierdzono największe ilości tlenków alkalicznych, odpowiedzialnych za odkładanie się osadów na urządzeniach grzewczych podczas spalania. Wskaźnik c_m wyniósł w przypadku ślazowca zebranego po pierwszym roku wegetacji 20,86, a dla roślin trzyletnich 16,60, podczas gdy w przypadku miskanta wartości te kształtowały się odpowiednio 0,24 i 0,19, zaś spartiny preriowej 0,69 i 0,39. Świadczy to o znacznie wyższym ryzyku osadzania się popiołu na urządzeniach grzewczych i mniejszej sprawności kotła podczas spalania biomasy ślazowca. Najwięcej chlorków zawierał popiół z biomasy jednorocznej spartiny preriowej, zaś w przypadku trzyletniego miskanta cukrowego nie stwierdzono obecności chlorków. Ponadto popiół z biomasy miskanta cukrowego cechował się najwyższymi temperaturami topliwosći.

Słowa kluczowe: biomasa, rośliny energetyczne, popiół, skład chemiczny, topliwosć

Krystyna HOFFMANN¹, Józef HOFFMANN¹
and Filip DONIGIEWICZ¹

INFLUENCE OF CONCENTRATION OF PHOSPHORIC ACID ON OBTAINED FODDER PHOSPHATE QUALITY

WPLYW STEŻENIA ZATEŻONEGO EKSTRAKCYJNEGO KWASU FOSFOROWEGO NA JAKOŚĆ OTRZYMANÝCH FOSFORANÓW PASZOWYCH

Abstract: Results of qualitative analysis of the fodder monocalcium phosphate product based on concentrated phosphoric acid obtained in the laboratory conditions were presented. Phosphoric acid was produced by wet method from apatite raw material. Phosphorus is essential, regarded as biogenic nutrient, in animal feeding. Moreover the form of its availability contained in fodder phosphates is of great significance. The aim of conducted research was to determine different forms of phosphorus in monocalcium phosphate and depict the relation between contents of phosphorus in the fodder phosphate and concentration of the phosphoric acid used for its production. Furthermore it was evaluated whether the product meets the requirements of the Polish Standard PN-R-64803 regarding contents of different forms of the phosphorus

Keywords: concentrated phosphoric acid, fodder phosphate, monocalcium phosphate, fodder additive

Phosphorus is one of the main nutrients present in the human and animals' body. It is included as an essential element into the composition of all cells of living organisms and it participates in transformations of energy and other nutrients. It is abundant in bones and blood.

Phosphorus is an integral part of organic compounds of both plants and animals. This element participates in energy and nutrients transformations such as: carbohydrates, proteins, lipids. It plays important role in the lipid transport system, in the phosphorylation process and absorption of carbohydrates and in the metabolism of nerve tissue. The molecules of phosphorus compounds are one of the fundamental building materials of the nucleic acids such as DNA and RNA and high energy compounds adenosine phosphates – ADP and ATP. The deficiency of this macronutrient in the food chain

¹ Institute of Inorganic Technology and Mineral Fertilizers, Wrocław University of Technology, ul. M. Smoluchowskiego 25, 50–372 Wrocław, Poland, phone: +48 71 320 30 39, email: jozef.hoffmann@pwr.wroc.pl

causes serious complications, among other disturbances it affects negatively the functioning of living organisms, the process of ossification, hunger, and the intensity of metabolism. Supplying phosphorus in required quantity and appropriate, available form is essential for correct human and animal development. One of the most profitable ways of providing people with bioavailable phosphorus is the intake of meat of a proper quality. Supplying people with proper and sufficient level of phosphorus is dependent on the balanced diet of animals which are part of the elementary human food chain. Selecting an appropriate form and dosage of phosphorus in fodder mixtures fitted for the particular animal species and their age has a great importance within this range.

Fodder phosphates such as monosodium phosphate, monocalcium phosphate, magnaphoscal, disodium phosphate, calcium-sodium phosphate, dicalcium phosphate, trisodium phosphate and dimagnesium phosphate can be applied as the fodder supplements containing phosphorus in fodder mixtures products. Biological value of mono- and dicalcium phosphates reaches over 100 points according to the Günther scale what confirms their very good biological quality [1].

Examinations were carried out for the *monocalcium phosphate* (MCP) due to the highest bioavailability and the content of another biogenic component included within its composition which is calcium. MCP is a fodder supplement which constitutes one of the main sources of the phosphorus and calcium in concentrates for all kinds of farm animals.

Calcium is biologically-essential nutrient. It can be found mainly in the bones in the forms of calcium-phosphorus compounds – hydroxyapatite. It plays important role in human and animal body, *inter alia* it takes part in blood clotting and transmission of bioelectrical impulses. Furthermore calcium is one of the enzymes activators, and participates in skeletal muscle contractions and systoles.

$\text{Ca}(\text{H}_2\text{PO}_4)_2$ has also found the application in fertilizer industry. It constitutes one of the components of fertilizer mixtures based on the superphosphates [2, 3]. MCP is used for the manufacture of detergents and cosmetics as well as an agent enhancing nutritional properties.

Large amount of phosphorus is emitted along with animal excrements what causes the need to replenish it in the diet, however it has also harmful influence on the environment resulting in pollution by water eutrophication. It is believed that phosphorus from excrements gets into ground water or sewages, and then goes into a water basins where, as a biogenic nutrient cause significant enrichment of waters with nutrients, thus stimulating the growth of phytoplankton and cyanobacteria. Excessive and acute growth of microorganisms as a coat on the water surface causes oxygen depletion in the water and death of many organisms. For this reason it is important to reduce emissions of this element to the environment [4].

Analytically phosphorus in the samples can be determined by different methods. The most popular test is the spectrophotometric determination using the energy transition which takes place in the molecules by absorption of electromagnetic radiation in the ultraviolet, near-infrared or ultraviolet-visible 380–780 nm.

In order to analyze phosphorus content during performed research the absorption test of a colored vanadate-molybdate complex in the visible spectra at $\lambda = 430$ nm

wavelength was used. Another method recommended in the Polish Standards, is gravimetric determination based on phosphate precipitation in the form of quinoline-phosphate-molybdate in an acidic environment. Both in fodders and fertilizers phosphorus content is expressed as P or P₂O₅ percentage by weight.

Analytic methods allow to determine the various forms of phosphorus such as available, water-soluble and total. These examinations provide very valuable information on the fodder's biological value. Having this knowledge it is possible to evaluate the quality of the sample and find the application which fits for it. Knowledge of the content of the various forms of phosphorus is especially important in animal nutrition because it helps to prepare the fodder mixtures with adequate phosphorus content, in order to stimulate normal animal growth.

Materials and methods

The investigation on the assessment of quality of the monocalcium phosphate were carried out for preparations obtained under laboratory conditions produced according to the following reaction:



In frames of examinations 6 samples of the monocalcium phosphate produced by grinding dicalcium phosphate with phosphoric acid were prepared [4]. The industrial wet phosphoric acid was concentrated to various concentration levels: 48 %, 52 %, 56 %, 60 %, 64 % and 67 % P₂O₅ w/w. The total and water-soluble phosphorus as well as phosphorus soluble in hydrochloric acid contents were determined in samples. In these samples, phosphorus was determined spectrophotometrically in the form of P₂O₅ by the so-called yellow method utilizing yellow complex of phosphorus with vanadate-molybdate reagent at wavelength of $\lambda = 430$ nm.

The examination of water-soluble phosphorus was carried out in accordance with Regulation of the Minister of Agriculture and Rural Development dated 27 June 2007 regarding methodology of analysis for determination of nutrients and fodder additives in fodder materials, premixes, fodder mixtures and therapeutic fodder and with PN-88/C-87015 Polish Standard [5–7].

Acid used for fodder phosphate samples production was prepared by concentration of wet phosphoric acid with an initial concentration of P₂O₅ about 24 % w/w.

The process of concentration was based on adding to 1500 cm³ of industrial acid appropriate amount of CaO and SiO₂ to remove F⁻ and SO₄²⁻ ions, and subsequent heating up in a reactor equipped with two scrubbers in series connection to a concentration of P₂O₅ 49.88 % w/w. Acid concentrated by this procedure was cooled, and then transferred to Imhoff funnels in order to separate sediment from acid. Separated acid was concentrated again under vacuum, to the P₂O₅ content assumed in the experiment. Laboratory-produced acid was applied to manufacture monocalcium phosphate by the reaction of concentrated phosphoric acid with dicalcium phosphate [8].

Elemental composition of the industrial acid used for manufacture of phosphoric acid of specified P_2O_5 content was determined using the ICP method. The results of the analysis were presented in Table 1.

Table 1

The results of ICP elemental analysis for concentrated wet phosphoric acid of P_2O_5 content 49.88 % w/w

Symbol of chemical element	Al	As	Ca	Cd	Cr	Cu	Fe	Hg	Mg	Mn	Pb	Zn
Concentration [mg/kg]	2280	10	91	32	307	32	5340	0.0011	4230	347	0.67	352
Uncertainty \pm [mg/kg]	460	2	14	5	46	5	800	0.0002	850	52	0.10	53

Methods of samples preparation for spectrophotometric analysis was different depending on determined form of phosphorus, and proceeded as follows:

Water-soluble phosphorus

Phosphate sample 1 g was added to 500 cm³ flask. Then 400 cm³ of water was poured and the flask was subsequently placed into the rotational set where it was shaken for 0.5 h at 45 rpm. Then a flask was filled up with water and components were carefully mixed. After precipitate sedimentation the solution was filtered through the dry filter into dry vessel.

Total phosphorus

Phosphate sample 1 g was added to 400 cm³ beaker. Then 50 cm³ of the nitric(V) and hydrochloric acid mixture at 3:1 ratio was introduced. The solution was boiled under the fume hood for 0.5 h. After this time 100 cm³ of water was added and boiled again for 0.25 h. Then mixture was cooled and transferred to the 500 cm³ flask quantitatively, carefully mixed and filtered rejecting about 50 cm³ of first part of the filtrate. Sample of 1 cm³ was collected for further analysis.

Phosphorus soluble in HCl 0.4 % w/w

Phosphate sample 1 g was added to 500 cm³ flask. Then 400 cm³ of 0.4 % w/w HCl was poured and the flask was subsequently placed into the rotational set where it was shaken for 0.5 h at 45 rpm. Then a flask was filled up with water and components were carefully mixed. After precipitate sedimentation the solution was filtered through the dry filter into dry vessel.

Spectrophotometric analysis

Samples of 1 cm³ obtained by the methods mentioned above were introduced into the 100 cm³ flask. Then the flask was filled with water up to 25 cm³ capacity and 20 cm³ of the yellow vanadate-molybdate complex was subsequently added. Solutions were left for 0.25 h at room temperature and then absorbance was measured at $\lambda = 430$ nm wavelength using spectrophotometer of the JASCO company. Contents of the phosphorus were found from the calibration curve which was prepared in earlier investigations.

Results and discussion

Results and parameters of manufacturing process referring to samples 1–6 were presented in the Table 2. Relation between the quantity of total, water-soluble, phosphorus soluble in 0.4 % w/w HCl and the concentration of phosphoric acid used in manufacturing process were depicted on Figs. 1–3.

Table 2

Dependence of contents of different forms of phosphorus contained in monocalcium phosphate on the phosphoric acid concentration used for samples production process [% P₂O₅ w/w]

Sample No.	Input concentration of phosphoric acid P ₂ O ₅	Concentration of water-soluble P ₂ O ₅	Concentration of P ₂ O ₅ soluble in 0.4 % HCl	Concentration of total P ₂ O ₅
1	48 % w/w	42.13 % w/w	43.31 % w/w	50.32 % w/w
2	52 % w/w	45.82 % w/w	46.51 % w/w	52.54 % w/w
3	56 % w/w	47.04 % w/w	49.54 % w/w	55.23 % w/w
4	60 % w/w	49.10 % w/w	50.89 % w/w	53.91 % w/w
5	64 % w/w	50.65 % w/w	51.74 % w/w	55.60 % w/w
6	67 % w/w	51.07 % w/w	52.78 % w/w	55.31 % w/w

The table shows the results of spectrophotometric measurements of all analyzed forms of phosphorus. The analysis of data collected in the table clearly shows that when the input concentration of phosphoric acid increases the concentration of all measured forms of phosphorus also elevates. All of the samples contained the highest amount of P₂O₅ in total form. Moreover it is shown that the content of P₂O₅ soluble in 0.4 % HCl is lower and the content of water soluble P₂O₅ is the lowest as all contents are compared. The difference between the content of water soluble P₂O₅ and P₂O₅ soluble in 0.4 % HCl is relatively low, which is an evidence of a high degree of bioavailability of phosphorus for animals.

The graph presents the relation between the amount of phosphorus water-soluble and concentration of acid used to prepare the sample. The analysis of the graph shows that with increasing concentration of the acid which the sample was prepared from, the increase in amount of water-soluble phosphorus i.e. bioavailable form of phosphorus for living organisms, is noticeable.

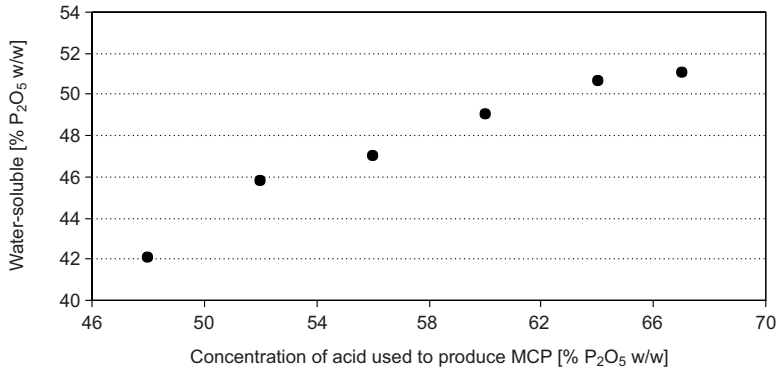

Fig. 1. Dependence of quantity of the water-soluble phosphorus on the acid concentration which the sample was produced from

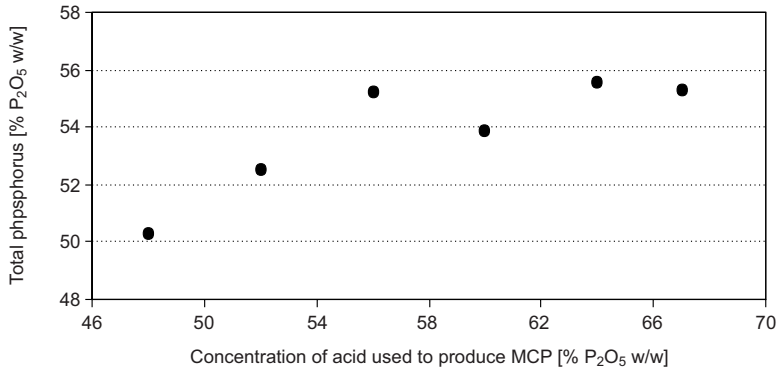

Fig. 2. Dependence of quantity of total form of phosphorus on the acid concentration which the sample was produced from

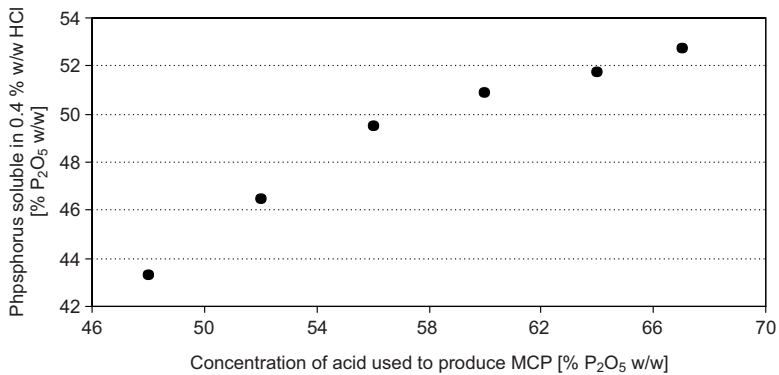

Fig. 3. Dependence of quantity of the phosphorus soluble in 0.4 % w/w HCl on the acid concentration which the sample was produced from

According to Polish Standard PN-R-64803 contents of total phosphorus in the monocalcium fodder phosphate should not be less than 50.41 % w/w of P_2O_5 . Samples 2–6 found to meet this requirement, content of phosphorus in the sample no. 1 is not corresponding with the standard. The clear correlation between the increase in acid concentration which the samples were prepared from and the growth of total concentration of P_2O_5 in the product can be spotted in this graph similarly like in the former one.

According to Polish Standard PN-R-64803 contents of the phosphorus soluble in 0.4 % w/w HCl in the monocalcium fodder phosphate should not be less than 54.83 % w/w of P_2O_5 . Samples 2–6 found to meet this requirement, contents of phosphorus in the sample no. 1 is not corresponding with the standard. The amount of P_2O_5 soluble in 0.4 % HCl increases as the concentration of the phosphoric acid used to prepare a sample grows, similar relation was shown in the former graphs.

Conclusions

All samples represent high contents of the water-soluble and phosphorus soluble in 0.4 % w/w HCl in relation to the total phosphorus. Such relation is very profitable by taking into consideration the fact that the large quantity of the phosphorus occurs in the sample in the available form.

Dependence of quantity of the various forms of P_2O_5 from the acid concentration which the sample was produced from is in all cases approximately linear function. This fact is caused by decreasing the humidity of the sample with the increase in the acid concentration.

The most profitable ratio of the available to total phosphorus content presents a sample produced from acid of the highest concentration (67 % w/w P_2O_5).

Sample no. 1 does not meet the standards requirement regarding contents of the both total and phosphorus soluble in 0.4 % w/w HCl.

Most preferred results of the analysis were revealed for the samples of fodder phosphates manufactured from concentrated dicalcium phosphate and phosphoric acid at a concentration above 60 % w/w of P_2O_5 .

References

- [1] Jamroz D., Podkówka W. and Hahułowa J.: *Żywienie zwierząt i paszoznawstwo*, t. 3, PWN, Warszawa 2001.
- [2] Schroeder J.: *Technologia związków fosforowych*, PWN, Warszawa 1955.
- [3] Hoffmann J., Hoffmann K. and Borowiec M.: *Badanie procesu neutralizacji kwasu fosforowego w technologii wytwarzania fosforanów paszowych*, *Przem. Chem.* 2009, **88**(4), 380–384.
- [4] Jamroz D.: *Żywienie zwierząt i paszoznawstwo*, t. 1, PWN, Warszawa 2001.
- [5] *Pasze Fosforany paszowe PN-R-64803*.
- [6] *Pasze. Oznaczenie zawartości fosforu metodą spektrometryczną PN-ISO 6491*.
- [7] *Rozporządzenie ministra rolnictwa i rozwoju wsi z dnia 27 czerwca 2007 r. w sprawie metodyki postępowania analitycznego w zakresie określania zawartości składników pokarmowych i dodatków paszowych w materiałach paszowych, premiksach, mieszankach paszowych i paszach leczniczych*.

- [8] Wadowski M., Donigiewicz F., Skiba T., Hoffmann J. and Hoffmann K.: *Badania nad zateżeniem ekstrakcyjnego kwasu fosforowego na potrzeby otrzymywania fosforanów paszowych*, Proc. ECOpole 2010, **4**(1), 121–126.

WPLYW STĘŻENIA ZATEŻONEGO EKSTRAKCYJNEGO KWASU FOSFOROWEGO NA JAKOŚĆ OTRZYMANÝCH FOSFORANÓW PASZOWÝCH

Instytut Technologii Nieorganicznej i Nawozów Mineralnych
Politechnika Wrocławska

Abstrakt: Przedstawiono wyniki oceny jakościowej jednowapniowego fosforanu paszowego otrzymanego z zateżonego, w warunkach laboratoryjnych, ekstrakcyjnego kwasu fosforowego wytworzonego z surowca apatytowego. Fosfor należy do koniecznych tzw. biogennych pierwiastków w żywieniu zwierząt. Duże znaczenie ma również forma jego występowania w dodatku paszowym. Niniejsze badania miały na celu oznaczenie różnych form fosforu w fosforanie jednowapniowym, oraz przedstawienie zależności między zawartością fosforu w fosforanie paszowym, a stężeniem przemysłowego kwasu fosforowego z jakiego został otrzymany. Sprawdzone również, czy produkt spełnia warunki Polskiej Normy PN-R-64803 dotyczące zawartości różnych form fosforu.

Słowa kluczowe: zateżony kwas fosforowy, fosforan paszowy, fosforan jednowapniowy, dodatek paszowy

Elżbieta HUZAR¹, Alicja WODNICKA¹
and Małgorzata DZIĘCIOŁ¹

**ANALYSIS OF VOLATILE COMPOUNDS
IN NAIL POLISH REMOVERS AS A CRITERION
OF HEALTH HAZARD DETERMINATION
AND COMMODITY EVALUATION**

**ANALIZA LOTNYCH SKŁADNIKÓW ZMYWACZY DO PAZNOKCI
JAKO KRYTERIUM OCENY ZAGROŻENIA ZDROWIA
I OCENY TOWAROZNAWCZEJ**

Abstract: The volatile organic compounds (VOCs) content in nail polish removers available on the home market was determined. Qualitative and quantitative analyses of acetone, methanol, ethanol, isopropanol and ethyl acetate were performed. Theoretical VOCs concentrations in the standard room and time for reduction to low values were calculated. On the basis of the results the commodity evaluation of nail polish removers was carried out. The performed investigations indicate that this group of product is very often adulterated.

Keywords: nail polish removers, volatile organic compounds, indoor air quality, commodity evaluation

Nowadays discomfort and health problems affecting people more as a result of the presence of harmful factors in their close environment than they used to. According to accessible literature, people spend about 80 % of the time in the indoor areas [1–3]. The recent announcements say the time spent indoor may reach even 90 %. In those conditions the *indoor air quality* (IAQ) is important, especially for children and elder people's health [2–4]. Factors directly influencing IAQ are physical, chemical and biological pollutants [2]. High level of this kind of pollution is a reason for numbers of health problems such as headaches, dizziness, irritation of eye, nose or throat mucosa, allergic reactions on skin, concentration troubles, insomnia, tiredness or problems in breathing. Those symptoms literature describes as SBS (*Sick Building Syndrome*) [2, 4–6].

Indoor air pollutants are emitted from different sources such as combustion by-products, cooking, construction materials, office and home equipment, and consumer

¹ Institute of Organic Chemical Technology, West Pomeranian University of Technology, al. Piastów 42, 71–065 Szczecin, Poland, phone: +48 91 449 45 12, email: elzbieta.huzar@zut.edu.pl

products [2–4, 7, 8]. Nitric and carbon oxides, *volatile organic compounds* (VOCs) and particulates are the most common indoor air pollutants [3]. Volatile organic compounds are defined as organic compounds with boiling points range from ca 50 to 260 °C [7]. Some studies reported correlation between symptoms of SBS and total VOCs concentration. In the majority of cases the incidence of symptoms is higher at increased total VOCs concentration [3, 9].

VOCs determined in indoor air belong to different groups of compounds. There are carbonyl compounds (aldehydes and ketones), aliphatic and aromatic hydrocarbons, terpenes, alcohols, esters, halogenated hydrocarbons, ethers and others [1–4, 6, 8, 10–12].

One of sources the above of compounds are consumer products [13], such as paints, polishes, cleaning products, deodorizers, glues, sealants and cosmetics [6, 13–15]. Six compounds usually are identified in all household classes (acetone, ethanol, perchloroethylene, phenol, 1-propanol and limonene) [14].

The household products accounted about 20 % of poisoning incidents and over 80 % of those are accidental child poisonings [15]. Data presented in the available literature shows that children younger than 6 years are the most frequently endangered by substances used in cosmetics [16].

High content of VOCs is noticed in nail lacquers and polish removers. Solvents are 70–80 % of their content. The most common solvents used in polishes are acetone, ethyl acetate, butyl acetate, toluene and isopropanol [17, 18]. The mentioned above compounds are also used as components of nail polish removers [17–19].

Kwon et al identified 12 substances contained in nail polish removers available on Korean market [14]. Four of the identified substances (acetone, butyl acetate, cyclohexane, 2,2,4-trimethyl-1,3-dioxolane) are characterised by high volatility and they are significantly responsible for indoor air pollution [13]. Research on nail polish removers available on Canadian market indicated emission of toluene, 2-butoxyethanol and ethyl acetate [13].

Components of nail polish removers directly react on a nail plate. Due to this fact, in recent years producers have limited use of acetone in nail polish removers. Acetone dries a nail plate when it is often used. Other solvents, eg ethyl acetate, are more gentle [19].

Taking into account the hazardous effects of acetone, consumers, examining the declared by producers ingredients used to production, nowadays choose acetone free products more often than they used to. Considering the cost of chemical agents, production of acetone free products is obviously more cost-consuming than production of the removers containing acetone. This fact may be used by unfair producers to reduce costs. The goal of this work was studies of available on the home market nail polish removers and determination of VOCs emission to indoor air.

Materials and methods

Nail polish removers available on the home market where used as the samples. The products were grouped into two classes: A – removers with declared acetone

content and B – acetone-free removers. There were 10 removers of A class and 7 of B class.

The studies of VOCs content in nail polish removers were performed by gas chromatography method. The applied method enables a selective determination of organic solvents in consumer products.

The samples of analyzed product (5 mm³ (μl) of nail polish removers) were injected into 1114 cm³ glass containers, tightly closed with the screw caps containing the silicon membranes. The samples were evaporated in thermostat chamber at temperature 50 °C. Next they were stabilized at the room temperature for 30 minutes. After equilibration the gas samples of 1 cm³ volume were drawn with a Hamilton gas-tight syringe and analyzed on a gas chromatograph equipped with a *flame-ionization detectors* (FID).

The qualitative and quantitative analyses of polish removers components were performed using a CHROM 5 gas chromatograph with FID detectors. The chromatograph was provided with two steel chromatographic columns. Column I was 2 meter long of 3 mm inside diameter packed with 8 % SE-30 + 0.21 % Carbowax 20M on Chromosorb W NAW (60–80 mesh). Column II was 1 meter long of 3 mm inside diameter packed with Chromosorb 102 (80–100 mesh). The following temperatures were applied: column I 50 °C, column II 100 °C, injectors 120 °C, detectors 150 °C. Nitrogen (40 cm³ · min⁻¹) was used as the carrier gas.

Identification of removers ingredients was performed on the both columns with the aid of acetone, methanol, ethanol, isopropyl alcohol, ethyl acetate, *n*-butyl acetate standards. All standards were of analytical purity.

Quantitative analyses of ethyl acetate and *n*-butyl acetate were performed on column I. On the column I peaks of acetone and other volatile compounds such as ethyl and isopropyl alcohols were not separated very well. Analyses of acetone, methanol, ethanol and isopropyl alcohol were performed on column II. The apparatus was calibrated using the standard gas mixtures prepared in the same containers and conditions in which the tested samples were prepared. The aim of this was to limit the errors resulting from analytes adsorption on the walls of the container. In order of that 5 mm³ of standard liquid mixtures were injected into 1114 cm³ containers, tightly closed with the screw caps containing the silicon membrane. Two standard mixtures were used for calibration. The first mixture contained methanol, ethanol, isopropanol and acetone (1:1:2:2). In the second ethyl and butyl acetate (1:2) were used, with acetone as a solvent. The further procedure was as for the samples of the nail polish removers (evaporation at 50 °C, stabilization at the room temperature). After equilibration gas mixtures of 0.4; 0.8; 1.2 and 1.6 cm³ volume were drawn with a Hamilton gas-tight syringe and analyzed on a gas chromatograph. The obtained calibration curves were rectilinear with the correlation coefficients in the range of 0.9953–0.9997.

Content of compounds *C* in the examined products was calculated from the following equation:

$$C = \frac{m \cdot V_C}{V_S \cdot V_R} \cdot 100 \text{ [g in } 100 \text{ cm}^3 \text{ of product]} \quad (1)$$

where: m – mass of the substance calculated from calibration curve [mg],
 V_C – volume of the container [cm^3],
 V_S – volume of gas sample injected to the chromatographic column [cm^3],
 V_R – volume of nail polish remover injected into container [μl].

Results and discussion

17 Samples of nail polish removers were examined. Results of the analyses of VOCs content in the examined samples are given in Tables 1 and 2.

Table 1

Contents of volatile organic compounds in the nail polish removers
with declared acetone content

Product	Substance	Content in product [g · 100 cm ⁻³]	Coefficient of variation RSD [%]	Summary VOCs content in product [g · 100 cm ⁻³]
A1	acetone	18.62	1.00	18.62
A2	acetone	76.75	1.47	76.75
A3	acetone	58.80	0.85	70.32
	ethanol	11.52	3.53	
A4	acetone	75.88	1.27	75.88
A5	acetone	66.80	0.69	66.80
A6	acetone	70.83	0.39	70.83
A7	acetone	64.65	4.11	64.65
A8	acetone	59.17	0.68	65.82
	ethanol	6.65	4.97	
A9	acetone	71.63	1.12	71.63
A10	acetone	67.35	3.19	67.35

In products of class A there were identified volatile substances as acetone and ethanol. Composition of products in class B was more varied. In those products methanol, ethanol, isopropanol and ethyl acetate were present. Additionally, there was identified acetone content in 5 samples although producers declared their products as acetone-free ones. In examined polish removers there was not identified *n*-butyl acetate.

It was found, that VOCs content in products of class A ranges from 64 to 77 g in 100 cm³ of product except for the product A1, where VOCs (acetone) content was less than 20 g in 100 cm³ of the product. VOCs content in products of class B ranged from 40 to 96 g in 100 cm³. Coefficients of variation (RSD) for the obtained results did not exceed 5 %. Higher values of RSD (16–22 %) were obtained analysing methanol in samples B5 and B7. Methanol content in those samples was very low (less than 0.5 g in 100 cm³).

Table 2

Contents of volatile organic compounds in the acetone-free removers

Product	Substance	Content in product [g · 100 cm ⁻³]	Coefficient of variation RSD [%]	Summary VOCs content in product [g · 100 cm ⁻³]
B1	acetone	50.42	0.59	72.21
	isopropanol	21.24	0.92	
	ethyl acetate	0.55	4.44	
B2	acetone	23.05	1.89	40.69
	methanol	17.64	4.83	
B3	methanol	5.64	1.04	71.15
	ethanol	23.76	2.65	
	ethyl acetate	41.75	2.23	
B4	acetone	17.39	3.36	84.12
	methanol	66.73	2.08	
B5	acetone	1.67	2.19	94.66
	methanol	0.30	16.37	
	ethanol	9.06	4.84	
	isopropanol	31.94	0.57	
	ethyl acetate	51.69	1.53	
B6	acetone	45.01	0.43	65.49
	isopropanol	20.48	0.72	
B7	methanol	0.07	21.53	87.39
	isopropanol	2.26	5.11	
	ethyl acetate	85.06	3.08	

Substances contained in nail polish removers may significantly affect indoor air quality. For that reason an attempt to determine concentration of those substances in indoor air was undertaken.

In order to determine the average use of nail polish removers a group of 10 women was questioned. The average use was determined to be 2.5–4 cm³ of product. Considering very high volatility of nail polish removers ingredients it may be assumed that all the ingredients are emitted into the air in very short time being a source of VOCs emission. It was assumed that the air was well mixed and that there were no sinks in the standard room. The initial concentrations of VOCs in the standard room of volume 17.4 m³ [12, 13] were calculated. Results are presented in the Table 3. VOCs concentrations were strongly high (> 3 mg · m⁻³) [9] and were in the majority of cases over 100 mg · m⁻³.

The time necessary to reduce the concentration of VOCs in the standard room to low concentration level (0.25 mg · m⁻³) was determined [9]. To gain the aim, the following assumptions were used.

Table 3

The initial concentrations of VOCs in the standard room and the time to reduce of concentrations to low values

Product	VOCs emission [g]	Initial average concentration of VOCs [$\text{mg} \cdot \text{m}^{-3}$]	Time to reduce of VOCs concentration to $0.25 \text{ mg} \cdot \text{m}^{-3}$ [h]
A1	0.47–0.74	34.78	7.12
A2	1.92–3.07	143.35	9.16
A3	1.76–2.81	131.34	9.04
A4	1.90–3.04	141.73	9.15
A5	1.67–2.67	124.77	8.96
A6	1.77–2.83	132.30	9.05
A7	1.62–2.59	120.75	8.92
A8	1.65–2.63	122.94	8.94
A9	1.79–2.87	133.79	9.06
A10	1.68–2.69	125.80	8.97
B1	1.81–2.89	134.88	9.08
B2	1.02–1.63	76.00	8.25
B3	1.78–2.85	132.90	9.05
B4	2.10–3.36	157.12	9.30
B5	2.37–3.79	176.81	9.47
B6	1.64–2.62	122.32	8.93
B7	2.18–3.50	163.23	9.35

Changes of VOCs concentration in the standard room may be presented in a geometric progression:

$$C_t = C_0 \cdot N^t \quad (2)$$

where: C_0 – initial concentration,
 C_t – concentration at the time t ,
 N – air exchange rate,
 t – time.

Take it for granted that concentration of volatiles in indoor air is regarded as a low, when its values is below $0.25 \text{ mg} \cdot \text{m}^{-3}$ [9], we obtain:

$$0.25 > C_0 \cdot N^t \quad (3)$$

Transforming the above relation we obtain relation (4) from which we may calculate the time necessary to reach the assumed concentration:

$$t > \frac{\log 0.25 - \log C_0}{\log N} \quad (4)$$

To estimate the necessary time to obtain concentrations below $0.25 \text{ mg} \cdot \text{m}^{-3}$, an average air exchange rate N of 0.5 h^{-1} was applied [13]. Results of calculations are presented in Table 3. The time to reduce of VOCs concentrations to low values appear to be in the range of 7–9.5 hours.

The described methodology together with gas chromatography may be used to commodity evaluation of nail polish removers. Results of investigation indicated that this group of product is very often adulterated.

There were examined 17 samples of nail polish removers. Producers declared acetone content in 10 of them but acetone was found in 15 samples. For declared acetone-free removers (class B) the factual state was according with producer's declaration about acetone absence only in two samples. In one sample of B class product (B5) acetone content was low and it was about 2 g in 100 cm^3 . In four „acetone-free” removers (B1, B2, B4, B6) acetone content was significantly higher and it ranged from 17 to 50 g in 100 cm^3 of product.

In products of class A in two cases (A3 and A8) some content of ethanol was found. Although producers declared ethyl acetate content, it was not identified in the A1 and A3 products.

Analysing polish removers of class B none of the examined samples contained *n*-butyl acetate. Its content was declared by four producers (B1, B2, B4, B6). Additionally declared content of products B2 and B4 was not in agreement with the factual state. In those products high contents of methanol and acetone were found, whereas producers declared butyl acetate (B4) or butyl acetate and isopropanol (B2). Very low content of methanol in products B3, B5 and B7 may result from pollution of alcohols used for nail polish removers production.

Conclusions

Analyses of 17 nail polish removers available on the home market were performed. In the products there were identified very volatile organic compounds such as acetone, methanol, ethanol, isopropyl alcohol and ethyl acetate. The composition of tested products often differs from declared by producers.

Calculated VOCs concentrations in the standard room during application of the tested products are strongly increased. Nail polish removers are a significant source of VOCs emission into the indoor air. The time to reduce of VOCs concentrations to low values appear to be in the range of 7–9.5 hours.

The described methodology may be used to control the quality of nail polish removers and evaluation of indoor air quality. The method is repeatable. Its advantage is low costs of analysis and undemanding apparatus requirements.

References

- [1] Li F.B., Li X.Z., Ao C.H., Lee S.C. and Hou M.F.: Chemosphere 2005, **59**, 787–800.
- [2] Zabiegała B., Partyka M. and Namieśnik J.: Jakość powietrza wewnętrznego – analityka i monitoring, [in:] Nowe horyzonty i wyzwania w analityce i monitoringu środowiskowym, Centrum Doskonałości Analityki i Monitoringu Środowiskowego, Gdańsk 2003.

- [3] Wang S., Ang H.M. and Tade M.O.: *Environ. Int.* 2007, **33**, 694–705.
- [4] Guieysse B., Hort C., Platel V., Munoz R., Ondarts M. and Revah S.: *Biotechnol. Adv.* 2008, **26**, 398–410.
- [5] Burge P. S.: *Occup. Environ. Med.* 2004, **61**, 185–190.
- [6] Kwon K.-D., Jo W.-K., Lim H.-J. and Jeong W.-S.: *J. Hazard. Mater.* 2007, **148**, 192–198.
- [7] Yu K.-P., Lee G.W.M., Huang W.-M., Wu C. and Yang S.: *Atmos. Environ.* 2006, **40**, 375–385.
- [8] Zabiegała B., Gawrońska A., Partyka M. and Namieśnik J.: *Ecol. Chem. Eng.* 2005, **12**, 191–207.
- [9] Hutter H.P., Moshhammer H., Wallner P., Tappler P. and Kundi M.: *Proceedings: Indoor Air 2005*, 3519–3522 (<http://www.innenraumanalytik.at/pdfs/vocbeijing.pdf>).
- [10] Liu W., Zhang J., Korn L.R., Zhang L., Weisel C.P., Turpin B., Morandi M., Stock T. and Colome S.: *Atmos. Environ.* 2007, **41**, 5280–5288.
- [11] Liu W., Zhang J., Zhang L., Turpin B. J., Weisel C.P., Morandi M.T., Stock T.H., Colome S. and Korn L.R.: *Atmos. Environ.* 2006, **40**, 2202–2214.
- [12] Wolkoff P.: *Atmos. Environ.* 1998, **32**, 2659–2668.
- [13] Zhu J., Cao X.-L. and Beauchamp R.: *Environ. Int.* 2001, **26**, 589–597.
- [14] Kwon K.-D., Jo W.-K., Lim H.-J.: *Environ. Sci. Pollut. Res.* 2008, **15**, 521–526.
- [15] Klepac T., Bušljeta I., Macan J., Plavec D. and Turk R.: *Arh. Hig. Rada Toksikol.* 2000, **51**, 401–407.
- [16] Litovitz T., White N.C. and Watson W.A.: *Clin. Ped. Emerg. Med.* 2005, **6**, 68–75.
- [17] Moossavi M and Scher R. K.: *Clin. Dermatol.* 2001, **19**, 445–448.
- [18] Marcinkiewicz-Salmonowiczowa J.: *Zarys chemii i technologii kosmetyków*. Politechnika Gdańska, Gdańsk 1995.
- [19] Peters B.I., Kerckhoff E., Kuska S., Schweig W. and Wulfhorst B.: *Kosmetyka. Podręcznik do nauki zawodu*. Poradnik. Wyd. Rea, Warszawa 2002.

ANALIZA LOTNYCH SKŁADNIKÓW ZMYWACZY DO PAZNOKCI JAKO KRYTERIUM OCENY ZAGROŻENIA ZDROWIA I OCENY TOWAROZNAWCZEJ

Instytut Techniki Chemicznej Organicznej
Zachodniopomorski Uniwersytet Technologiczny w Szczecinie

Abstrakt: Przeprowadzono badania zawartości lotnych składników zmywaczy do paznokci dostępnych na rynku krajowym. W badanych produktach zidentyfikowano i oznaczono ilościowo: aceton, metanol, etanol, izopropanol i octan etylu. Określono teoretyczne stężenia lotnych związków organicznych wydzielających się ze zmywaczy do paznokci w pomieszczeniu standardowym i wyznaczono czas niezbędny do uzyskania niskich wartości tych stężeń. Na podstawie tych wyników dokonano oceny towaroznawczej zmywaczy do paznokci. Wyniki badań wskazują, że skład większości produktów nie jest zgodny ze składem deklarowanym przez producentów.

Słowa kluczowe: zmywacze do paznokci, lotne związki organiczne (VOCs), jakość powietrza wewnętrznego, ocena towaroznawcza

Varia

Invitation for ECOpole '11 Conference

CHEMICAL SUBSTANCES IN ENVIRONMENT



We have the honour to invite you to take part in the 20th annual Central European Conference ECOpole '11, which will be held in **13–15 X 2011** (Thursday–Saturday) at the Conference Center “Rzemieślnik” in Zakopane, PL.

The Conference Programme includes oral presentations and posters and will be divided into five sections:

- SI Chemical Pollution of Natural Environment and Its Monitoring
- SII Environment Friendly Production and Use of Energy
- SIII Risk, Crisis and Security Management
- SIV Forum of Young Scientists and Environmental Education in Chemistry
- SV Impact of Environment Pollution on Food and Human Health

The Conference language is English.

The Conference Opening Lecture:

“Atmospheric Chemistry and Climate in the Anthropocene”

will be delivered by the **Nobel Prize Winner**

Professor Dr. Paul Jozef CRUTZEN.

Contributions to the Conference will be published as:

- abstracts on the CD-ROM (0.5 page of A4 paper sheet format)
- extended Abstracts (4–6 pages) in the semi-annual journal *Proceedings of ECOpole*
- full papers will be published in successive issues of the *Ecological Chemistry and Engineering/Chemia i Inżynieria Ekologiczna* (Ecol. Chem. Eng.) ser. A or S.

Additional information one could find on the Conference website:

ecopole.uni.opole.pl

The deadline for sending the Abstracts is **31.08.2011** and for the Extended Abstracts: **1.10.2011**. The actualised list (and the Abstracts) of the Conference contributions

accepted for presentation by the Scientific Board, one can find (starting from 15.07.2011) on the Conference website.

The papers must be prepared according to the Guide for Authors on Submission of Manuscripts to the Journals.

At the Reception Desk each participant will obtain a CD-ROM with abstracts of the Conference contributions as well as Conference Programme (the Programme will be also published on this site).

Further information is available from:

Prof. dr hab. Maria Waclawek

Chairperson of the Organising Committee
of ECOpole '11 Conference

University of Opole

email: Maria.Waclawek@o2.pl

and mrajfur@o2.pl

phone +48 77 455 91 49 and +48 77 401 60 42

fax +48 77 401 60 51

Zapraszamy
do udziału w Środkowoeuropejskiej Konferencji
ECOpole '11
w dniach 13–15 X 2011

SUBSTANCJE CHEMICZNE
W ŚRODOWISKU PRZYRODNICZYM



Będzie to dwudziesta z rzędu konferencja poświęcona badaniom podstawowym oraz działaniom praktycznym dotycząca różnych aspektów ochrony środowiska przyrodniczego. Odbędzie się ona w Ośrodku Konferencyjno-Wypoczynkowym „Rzemieślnik” w Zakopanem.

Doroczne konferencje ECOpole mają charakter międzynarodowy i za takie są uznane przez Ministerstwo Nauki i Szkolnictwa Wyższego.

Obrady konferencji ECOpole '11 będą zgrupowane w pięciu sekcjach:

- SI Chemiczne substancje w środowisku przyrodniczym oraz ich monitoring
- SII Odnawialne źródła energii i jej oszczędne pozyskiwanie oraz użytkowanie
- SIII Zarządzanie środowiskiem w warunkach kryzysowych
- SIV Forum Młodych (FM) i Edukacja prośrodowiskowa
- SV Wpływ zanieczyszczeń środowiska oraz żywności na zdrowie ludzi.

Pan **Profesor Dr Paul Jozef CRUTZEN** – Laureat Nagrody Nobla
wygłosi referat inauguracyjny:

„Atmospheric Chemistry and Climate in the Anthropocene”

Materiały konferencyjne będą opublikowane w postaci:

- abstraktów (0,5 strony formatu A4) na CD-ROM-ie;
- rozszerzonych streszczeń o objętości 4-6 stron w półroczniku *Proceedings of ECOpole*;
- artykułów: w abstraktowanych czasopismach: *Ecological Chemistry and Engineering/Chemia i Inżynieria Ekologiczna (Ecol. Chem. Eng.)* ser. A i S oraz niektórych w półroczniku *Chemia – Dydaktyka – Ekologia – Metrologia*.

Termin nadsyłania angielskiego i polskiego streszczenia o objętości 0,5–1,0 strony (wersja cyfrowa + wydruk) planowanych wystąpień upływa w dniu 31 sierpnia 2011 r. Lista prac zakwalifikowanych przez Radę Naukową Konferencji do prezentacji będzie sukcesywnie publikowana od 15 lipca 2011 r. na stronie internetowej

ecopole.uni.opole.pl

Aby praca (dotyczy to także streszczenia, które powinno mieć tytuł w języku polskim i angielskim, słowa kluczowe w obydwu językach) przedstawiona w czasie konferencji mogła być opublikowana, jej tekst winien być przygotowany zgodnie z wymaganiami stawianymi artykułom drukowanym w czasopiśmie *Ecological Chemistry and Engineering* ser. A oraz S, które jest dostępne w wielu bibliotekach naukowych w Polsce i za granicą. Są one takie same dla prac drukowanych w półroczniku *Chemia – Dydaktyka – Ekologia – Metrologia*. Zalecenia te są również umieszczone na stronie internetowej konferencji.

Po konferencji zostaną wydane 4–6-stronicowe rozszerzone streszczenia wystąpień w półroczniku *Proceedings of ECOpole*. Artykuły te winny być przesłane do **1 października 2011 r.** Wszystkie nadsyłane prace podlegają zwykłej procedurze recenzyjnej. Wszystkie streszczenia oraz program Konferencji zostaną wydane na CD-ROM-ie, który otrzyma każdy z uczestników podczas rejestracji. Program będzie także umieszczony na stronie internetowej Konferencji.

Prof. dr hab. Maria Waclawek
Przewodnicząca Komitetu Organizacyjnego
Konferencji ECOpole '11

Wszelkie uwagi i zapytania można kierować na adres:

Maria.Waclawek@o2.pl

lub mrajfur@o2.pl

tel. 77 401 60 42 i 77 455 91 49

fax 77 401 60 51

GUIDE FOR AUTHORS ON SUBMISSION OF MANUSCRIPTS

A digital version of the Manuscript addressed:

Professor Witold Waclawek
Editorial Office of monthly *Ecological Chemistry and Engineering*
(Ecol. Chem. Eng.)
Uniwersytet Opolski
ul. kard. B. Kominka 6, 45-032 Opole, Poland
Phone +48 77 401 60 42, fax +48 77 401 60 51,
Email: waclawek@uni.opole.pl

should be sent by email to the Editorial Office Secretariat – mrajfur@o2.pl

The Editor assumes, that an author submitting a paper for publication has been authorised to do that. It is understood the paper submitted to be original and unpublished work, and is not being considered for publication by another journal. After printing, the copyright of the paper is transferred to *Towarzystwo Chemii i Inżynierii Ekologicznej (Society for Ecological Chemistry and Engineering)*. In preparation of the manuscript please follow the general outline of papers published in the most recent issues of *Ecol. Chem. Eng.*, a sample copy can be sent, if requested.

Papers submitted are supposed to be written in English language and should include a summary and keywords, if possible also in Polish language. If not then the Polish summary and keywords will be provided by the Editorial Office. All authors are requested to inform of their current addresses, phone and fax numbers and their email addresses.

It is urged to follow the units recommended by the *Système Internationale d'Unites* (SI). Graph axis labels and table captions must include the quantity units. The use of the following commonly applied expressions is recommended: mass – m/kg, time – t/s or t/min, current intensity – I/A; thermodynamic temperature – T/K, Celsius scale temperature – t/°C or θ /°C (if both time and Celsius scale units need to be used, the symbol θ /°C for temperature is to be taken) etc.

Symbols recommended by the International Union of Pure and Applied Chemistry (Pure and Appl. Chem., 1979, **51**, 1–41) are to be followed.

Graphics (drawings, plots) should also be supplied in the form of digital vector – type files, e.g. Corel-Draw, Grapher for Windows or at least in a bitmap format (TIF, PCK, BMP). In the case of any query please feel free to contact with the Editorial Office.

Footnotes, tables and graphs should be prepared as separate files.

References cited chronologically should follow the examples given below:

[1] Kowalski J. and Malinowski A.: Polish J. Chem. 1990, **40**(3), 2080–2085.

[2] Nowak S: Chemia nieorganiczna, WNT, Warszawa 1990.

[3] Bruns I., Sutter K., Neumann D. and Krauss G.-J.: *Glutathione accumulation – a specific response of mosses to heavy metal stress*, [in:] Sulfur Nutrition and Sulfur Assimilation in Higher Plants, P. Haupt (ed.), Bern, Switzerland 2000, 389–391.

Journal titles should preferably follow the Chem. Abst. Service recommended abbreviations.

Receipt of a paper submitted for publication will be acknowledged by email. If no acknowledgement has been received, please check it with the Editorial Office by email, fax, letter or phone.

ZALECENIA DOTYCZĄCE PRZYGOTOWANIA MANUSKRYPTÓW

Praca przeznaczona do druku w miesięczniku *Ecological Chemistry and Engineering A/Chemia i Inżynieria Ekologiczna A* powinna być przesłana na adres Redakcji:

Profesor Witold Waclawek
Redakcja Ecological Chemistry and Engineering
Uniwersytet Opolski
ul. kard. B. Kominka 6, 45–032 Opole
tel. 77 401 60 42, fax 77 401 60 51
email: waclawek@uni.opole.pl

w postaci cyfrowej w formacie Microsoft Word (ver. 7.0 dla Windows) emailem (mrajfur@o2.pl) lub na dyskietce.

Redakcja przyjmuje, że przesyłając artykuł do druku autor w ten sposób oświadcza, że jest upoważniony do tego oraz zapewnia, że artykuł ten jest oryginalny i nie był wcześniej drukowany gdzie indziej i nie jest wysłany do druku gdzie indziej oraz, że po jego wydrukowaniu copyright do tego artykułu uzyskuje Towarzystwo Chemii i Inżynierii Ekologicznej.

W przygotowaniu manuskryptu należy przede wszystkim wzorować się na postaci najnowszych artykułów opublikowanych w *Ecological Chemistry and Engineering*, na przykład zamieszczanych na stronie internetowej Towarzystwa:

<http://tchie.uni.opole.pl/>

Prace przesyłane do publikacji winny być napisane w języku angielskim oraz zaopatrzone w streszczenia oraz słowa kluczowe w języku angielskim oraz polskim.

Zalecamy, ażeby artykuł zawierał adresy i emaile oraz numery telefonów i faksów wszystkich autorów danej pracy, szczególnie głównego autora, którego nazwisko wyróżniamy gwiazdką.

Usilnie prosimy o stosowanie układu jednostek SI. Zwracamy uwagę, że osie wykresów oraz główki tabel powinny bezwzględnie zawierać jednostki stosownej wielkości. Polecamy symbolikę zalecaną przez PTChem (Symbole i terminologia wielkości i jednostek stosowanych w chemii fizycznej, Ossolineum, Wrocław 1989; Pure Appl. Chem. 1979, **51**, 1–41). Materiał graficzny (rysunki, wykresy), obok wersji na papierze, powinien również być dostarczony w postaci cyfrowych plików wektorowych, np. za pomocą programu: CorelDraw wersja 3.0–8.0, Grafer dla Windows lub przynajmniej bitowe (TIF, PCX, BMP). W przypadku trudności z wypełnieniem tego warunku Redakcja

zapewnia odpłatne wykonanie materiału graficznego na podstawie dostarczonego szkicu, bliższe informacje można uzyskać telefonicznie 077 401 60 42.

Przypisy i tabele podobnie jak rysunki zapisujemy jako osobne pliki.

Literaturę prosimy zamieszczać wg poniższych przykładów:

[1] Kowalski J. and Malinowski A.: Polish J. Chem. 1990, **40**, 2080–2085.

[2] Nowak S.: Chemia nieorganiczna, WNT, Warszawa 1990.

[3] Bruns I., Sutter K., Neumann D. and Krauss G.-J.: *Glutathione accumulation – a specific response of mosses to heavy metal stress*, [in:] Sulfur Nutrition and Sulfur Assimilation in Higher Plants, P. Haupt (ed.), Bern, Switzerland 2000, 389–391.

Tytuły czasopism należy skracać zgodnie z zasadami przyjętymi przez amerykańską Chemical Abstracts Service. Autor może, jeżeli uważa to za wskazane, podawać też tytuł cytowanych artykułów z czasopism, który będzie składany kursywą oraz numer zeszytu danego woluminu (w nawiasie, po numerze woluminu).

Redakcja potwierdza emailem otrzymanie artykułu do druku. W przypadku braku potwierdzenia prosimy o interwencję: emailem, faksem, listem lub telefonicznie.

REDAKTOR TECHNICZNY

Halina Szczegot

SKŁAD I ŁAMANIE

Jolanta Brodziak

PROJEKT OKŁADKI

Marian Wojewoda

Druk: „Drukarnia Smolarski”, Józef Smolarski, 45-326 Opole, ul. Sandomierska 1. Objętość: ark. wyd. 13,00, ark. druk. 10,50. Nakład: 350 egz. + 5 nadb. aut.

